

FREE DISTRIBUTION ONLY. NOT FOR SALE

## Antique Pattern Library

For more information, please see our website at: <http://www.antiquepatternlibrary.org>

This is a scan of an antique book that is, to the best of our knowledge, in the public domain. The scan itself has been edited for readability, and is licensed under the **Creative Commons** Attribution-NonCommercial-ShareAlike License. To view a copy of this license, visit <http://creativecommons.org/licenses/by-nc-sa/2.5/> or send a letter to Creative Commons, 559 Nathan Abbott Way, Stanford, California 94305, USA.

**You may share copies or printouts of this scan freely. You may not sell copies or printouts.**

*Antique Pattern Library is a project of New Media Arts, Inc. <http://www.newmediaarts.org>, a nonprofit organization tax exempt under IRC 501(c)(3). Donations may be tax deductible, depending on your tax status and tax jurisdiction.*

Donated by

# RIBBON ART

How to make  
Hundreds of  
Dainty and  
Practical things  
of Ribbons

*Illustrated in Colors  
with Detailed  
Instructions*

25¢



NELL HATT



*Fanciful Decorations Like These Supply the Artistic Touches Required for the Home and Boudoir*

The  
**RIBBON ART**  
Book

VOL. I NO. 1

**SPRING**  
1923

Price, 25c.



**INDEX OF CONTENTS**

To find easily and quickly any subject or article desired, refer to pages here indicated

PAGE	PAGE	PAGE	PAGE
Baby Basket .....	8	Coatees .....	6, 14
Baby Bonnet Box.....	6	Cockades .....	28, 29, 33, 36
Baby Bunting .....	7	Collar and Cuffs.....	23
Baby Caps .....	6, 9, 14	Costumes, Fancy Dress.	19
Baby Chifforobe .....	8	Crocheted Articles .....	14
Baby Clothes Hanger...	6	Cushions .....	20, 21, 44, 45
Baby Coatees .....	6, 14	(inside covers)	
Baby Hot Water Bag...	9	Curtains .....	43
Baby Pillows .....	7, 8	(inside covers)	
Baby Scales .....	9	Descriptions and dia-	
Bassinette .....	8	grams .....	40, 48
Bags .....	14, 30, 42	Doll Lamp .....	25
Bandeaux .....	3, 4, 5, 11, 25	Doll Pincushions .....	25, 44
Baskets, Sewing.....	25, 30	Dresses, Children's.....	22
Baskets, Waste.....	21, 24, 46	Dresses, Girls' .....	10
Birth Announcements...	7	Dress Accessories	
Blanket .....	7, 9	23, 33, 34, 35, 36, 37	
Bloomers .....	12	Dress Trimmings	
Bonnets, Baby .....	6, 9, 14	10, 15, 22, 33, 34, 35, 36, 37	
Bonnet Box, Baby's....	6	Dresser Box .....	46, 47
Bootees .....	6	Dresser Scarf .....	46
Boudoir Box .....	46, 47	Dressing Jacket .....	12
Boudoir Caps .....	3, 4, 5, 11	Fancy Dress Costumes.	19
Boudoir Lamps .....	25, 46	Favors .....	18, 19
Boudoir Novelties		Flowers	
24, 25, 44, 47		28, 29, 36, 37, 38, 39, 40, 48	
Boudoir Pillows .....	45	Garters .....	7, 17, 22
Boudoir Slippers .....	11, 14	Girdles, Girls' .....	10, 28, 29
Boxes .....	6, 18, 19, 46, 47		
Bows .....	15, 16		
Brassiere .....	12		
Bridal Suggestions....	26, 27		
Bridal Head Dress....	26, 27		
Bridal Lingerie .....	27		
Brush Bag .....	30		
Buds .....	38, 39, 40, 48		
Camisoles .....	12, 13, 27		
Candle Shades .....	41		
Caps, Baby .....	6, 9, 14		
Cape, Child's .....	22		
Carriage Clamps .....	7		
Carriage Robe .....	9		
Carriage Strap .....	9		
Chifforobe, Baby .....	8		
Children's Apparel.....	22		
Clothes Hangers .....	6, 46		
Coat, Jacket .....	23		
Girls' Apparel .....	10, 22		
Graduation Accessories.	10		
Hair Bows .....	10, 15, 16, 22		
Hair Ornaments.....	3, 5, 25		
Hair Receiver .....	46		
Hand Bags .....	14, 42		
Handkerchief Bags and			
Cases .....	4, 30, 46, 47		
Hangers .....	6, 46		
Hats .....	10, 22, 23, 31, 32, 48		
Hat Trimmings			
31, 32, 33, 34, 35, 36, 37			
Head Dress .....	3, 5, 25, 27		
Infants' Accessories			
6, 7, 8, 9			
Infants' Apparel.....	6, 7, 9, 14		
Instructions .....	40, 48		
Knitted Articles .....	14		
Knitting Bags .....	30		
Lamps .....	21, 25, 41, 46		
(inside covers)			
Lampshades			
21, 24, 41, 44, 45, 47			
Linen Bands .....	3, 43, 47		
Linen Closet Accessories			
43			
Lingerie .....	12, 13, 27		
Lingerie Bands .....	3, 47		
Lingerie Pins .....	7		
Millinery .....	23, 31, 32		
Millinery Trimmings			
31, 32, 33, 34, 35, 36, 37			
Neckpieces .....	23		
Negligees .....	11, 13		
Nightgowns .....	13, 27		
Nightgown Case .....	45		
Novelties .....	3, 24, 25, 44, 46, 47		
Ornaments .....	10, 28, 29, 36, 37		
Petticoat .....	27		
Pillows .....	7, 8, 20, 21, 44, 45		
Pincushions .....	4, 25, 44		
Pin Tray .....	46		
Powder Case .....	5, 46, 47		
Powder Jar .....	47		
Powder Puff .....	3		
Purses .....	42		
Rosettes .....	15, 16, 22, 28, 29		
Sachets.....	3, 4, 5, 24, 26, 46		
Sacque, Baby .....	6		
Sashes .....	10, 22, 28, 29		
Scarfs, Table (inside cover)			
Scarf, Dresser .....	46		
Sconce .....	24, 41		
Sewing Bag .....	30		
Sewing Basket .....	25, 30		
Sewing Doll .....	4		
Sewing Kit .....	47		
Shoe Cockades .....	17		
Shoe Trees .....	24		
Slippers .....	11, 14		
Slipper Bag .....	30		
Sport Coat .....	23		
Step-ins .....	12, 13, 27		
Sweater, Sleeveless Coat			
14, 23			
Table Decorations.....	18		
Table Scarfs .....	21		
(inside cover)			
Telephone Doll .....	24, 44		
Telephone Screen.....	24, 44, 47		
Trimmings, Dress or Hat			
15, 22, 33, 34, 35, 36, 37			
Underwear .....	12, 13, 27		
Vanity Cases .....	3, 5, 47		
Vests .....	12, 13		
Vestee .....	23		

*Acknowledgment is made here of the publishers' indebtedness to the editors of many important magazines of national circulation who assisted with valuable advice in the preparation of "Ribbon Art"*

Endorsed by The Silk Association of America

Published by  
**RIBBON ART PUBLISHING CO., INC.**  
354 Fourth Avenue, New York, N. Y.

GEORGE D. HIRST, President      FRANK G. BARRY,  
MARGARET R. BIRMINGHAM,      Secretary and Treasurer  
Vice President      F. BERTE BERGERE, Editor

Application for entry as second-class matter pending

# The Romance of Ribbon

**A**TINY streamer from the seal of a state document, a knot of ribbon carried by a knight as his lady's favor, a rosette from a little slipper, a strip of tri-colored glory—tokens of tragedy, love, bravery. Thus, through the pages of history winds the romance of ribbon.

It was during the reign of Queen Elizabeth that ribbon, as we know it today, first came into use. The *elegantes* of both sexes welcomed it with great enthusiasm. "At this day"—we quote a historian—"men of meane rank weare garters and shoe roses of more than five pounds price." And the ladies twisted ribbon in their elaborate headgear and with lavish hands sprinkled rosettes, bows and love-knots upon their gorgeous dresses.

A more practical use for ribbon was found in Scotland, where, until recent years, a snood or ribband on the hair signified that the young lady was unmarried, in much the same fashion as a blue ribbon or a pink one run through a wee frock means "it's a boy" or "a baby girl," as the case may be.

But ribbon reached even greater heights in the days of Louis XVI. Not only did the gentlemen wear hair ribbons, and their ladies be-ribbon almost everything they wore, but they gave their ribbons such descriptive titles



**RIBBON!**— *Beloved of fashion, it creates the smartest articles of wearing apparel. Irresistible in its dainty charm it appears in fashion and in decoration. The beauty and atmosphere of the home depend upon it. Make some of these things yourself. Let "Ribbon Art" guide you.*



as "Attention," "Mark of Hope," "Downcast Eye," "Sigh of Venus." It must have been amusing to match one's mood with one's ribbon.

Sometimes gleaming, sometimes sombre, ribbon winds its way through history. Today it swirls about us in its fullest glory, exquisite and fascinating, in myriad patterns and in colors that mock the rainbow!

There is something so charmingly feminine about ribbon; it lends itself to such dainty effects. Small wonder that it has endeared itself not only to fashion but to beautiful home decoration.

In this book are shown hundreds of ribbon uses, smart articles of wearing apparel, clever little Frenchy fashions, irresistible accessories, daintiest baby things, simple practical household usages, innumerable ribbony ways.

To make a smart hat, a baby sacque, a picturesque sweater, entirely of ribbon; to pick up a shimmery ribbon length, twist it in your fingers and find it has been transformed into a lovely blossom; to fold a bit of ribbon this way and that, and achieve the voguish trimming that the most expensive frocks are featuring; to run a yard or so of ribbon through your lingerie and find it fresh and new again; to make lovely things lovelier—these are the joys that ribbon brings to you!



## UNUSUAL HAIR ORNAMENTS—BOUDOIR DAINTIES



Each of the sachet pads is  $2\frac{1}{2}$  inches square. 7 strips 4 inches long of  $\frac{1}{4}$ -inch 2-tone ribbon are used for the latticed top (see page 40), and 3 inches of  $2\frac{1}{2}$ -inch ribbon for back. The bias ends of each of the latticed strips form a pointed edging around each pad.  $\frac{3}{4}$  yard of the narrow ribbon is used for the streamers.



The head band to the left requires  $\frac{3}{4}$  yard of  $\frac{3}{4}$ -inch metallic ribbon for the band to fit around head and  $3\frac{1}{2}$  yards of 1-inch 2-tone ribbon for petals and leaves.  $2\frac{1}{2}$  inches is required for each petal twisted to show both tones of ribbon. Leaves require 2 inches with edges rolled to center to form shape of leaf.

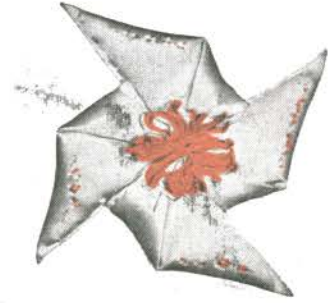

The pinwheel sachet case is made of 4 separate pads. Each is a triangle  $3\frac{1}{2}$  inches at the base. One of the points at the base of each triangle is turned back to meet the center. Little hand-painted flowers and a knotted rosette of  $1\frac{1}{2}$  yards of baby ribbon decorate the center.



The ruffled boudoir cap above is made of many dainty ribbon ruffles, finely plaited, and is made on a foundation of net. Streamers of colored ribbon hang from the top. See page 11.



Boudoir caps made of lace and ribbon are the height of fashion. The one above measures one yard at the circumference. The top is made of lace 12 inches in diameter shirred slightly around a ribbon 6 inches wide, allowing 1 inch of the ribbon on top for ruffling. Lace edging 2 inches wide is placed underneath the lower edge of the ribbon, allowing  $\frac{1}{2}$  inch of the lace to protrude from it. One yard of  $\frac{1}{4}$ -inch ribbon is placed around the brim through which elastic is drawn.  $\frac{3}{4}$  yard of 4-inch ribbon trims the front, and 5-inch streamers allowed at either side. Buds and tiny streamers further decorate the cap.



The vanity case above in its many rows of dainty ribbons gives ample cause for its name. The bag is made of  $\frac{1}{2}$  yard of 6-inch satin ribbon, upon which the rows of gathering are stitched. 6 yards of 1-inch ribbon are used for the 9 rows of ruffling. 2 buds of 6-inch ribbon in a contrasting color decorate the bag. A mirror 2 inches in diameter is sewed to bottom.



The nightgown hanger is made as follows: A hoop 12 by 6 is covered with  $1\frac{1}{8}$  yards of 4-inch ribbon folded in half and sewed tightly over the hoop. 10 loops each 4 inches long are made of 1-inch 2-tone ribbon.  $1\frac{1}{2}$  yards of 1-inch ribbon makes the bows and streamers.



The lingerie band or linen band is made of  $1\frac{1}{8}$  yards of 2-inch ribbon edged with French val lace. A sachet is attached at one end under band, and a slide 2 inches wide by 5 inches long is made to regulate the band. 2 flowers and buds decorate the front part. Other bands, pages 3, 43 and 47.



The above powder puff and mirror claim first place in originality. Both are attached to handles 7 inches long and require  $\frac{1}{2}$  yard of  $\frac{1}{2}$ -inch ribbon to cover them.  $\frac{1}{8}$  yard of  $\frac{3}{4}$ -inch ribbon is shirred at both ends and placed around the mirror and same amount around the puff.  $\frac{1}{8}$  yard of  $\frac{1}{2}$ -inch lace is placed around the circumference to add a finishing touch to the set. The backs of mirror and puff are covered with ribbon.

*Buds and Flowers are illustrated and described in detail on pages 38 and 39.*

## BOUDOIR LUXURIES CAST A RIBBON CHARM



The boudoir cap above is made as follows: 2 contrasting shades of ribbon 32 inches long and 4 inches wide are sewed together with over-casting stitches at outer edge, and the other edge shirred on wire for head-size. 2 strips 32 inches long of either color are shirred for crown, a wire inserted where the 2 strips are sewed together. The top is shirred to a point. The cap is dented and buds placed at each dent.



The case which may hold Milady's dainty handkerchiefs or head bands is made in lattice work of  $\frac{1}{2}$ -inch ribbon. 17 yards of ribbon is used for the case 10 by 5 inches, and  $\frac{3}{4}$  of a yard for the bow. 30 inches of 5-inch ribbon is used for the lining. Buds and streamers decorate the front. The case may be fastened with snaps or tied by means of the streamers. (For lattice work or blocking, see page 40.)



The head band above serves the purpose of a boudoir cap. It is made on a net foundation and measures 17 inches from point to point. The ribbon is shirred before it is sewed to the net. 10 yards of  $\frac{1}{2}$ -inch ribbon is required. 2 yards are used for the streamers and 1 yard for the back band through which elastic is drawn and which is fastened with snaps at one side. Buds decorate the front.



Above is a hair band made of ribbon, to serve as a more decorative boudoir cap. 12 yards of  $\frac{1}{4}$ -inch two-tone picot-edge ribbon is required for the whole: 8 bands, each  $\frac{1}{2}$  yard, form the framework. Rosettes are placed on either side, the larger one measuring 4 yards and the smaller one 2 yards, both finished off with streamers. Each row is decorated with buds in the center, held solid on a wire foundation. From one side extends a braided band which reaches around the back of the head and fastens at the other side.

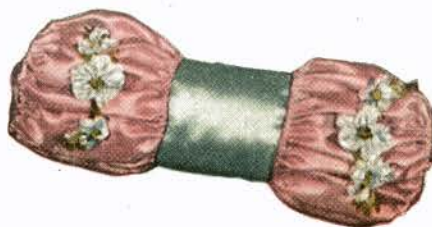

To serve for a pin cushion or sachet bag! The center is made of 6 inches of ribbon  $2\frac{1}{2}$  inches wide.  $\frac{1}{2}$  yard of 3-inch ribbon of contrasting color is used for the sides, shirred at both ends to fit the 6-inch circumference. 3 inches of the  $2\frac{1}{2}$ -inch ribbon is cut lengthwise and placed in the center on either side around which the ends are shirred and fastened.



The lady above conceals a needle case and a cotton holder.  $\frac{1}{2}$  yard of 7-inch ribbon is used for the dress.  $\frac{3}{4}$  yard lace is gathered for lace ruffle.  $\frac{1}{4}$  yard of 4-inch ribbon is draped around the waist. 1 yard of 1-inch ribbon is used around hoop and  $\frac{3}{4}$  yard of  $\frac{1}{2}$ -inch ribbon for the bows on top. 12 inches of the ribbon is twisted into loops and fastened in back. (See page 48.) On each loop a small spool of cotton is inserted. 3 pieces of flannel about 4 inches square are covered with ribbon top and bottom and inserted underneath dress for needles.

Detailed drawings and descriptions of Buds are found on pages 38 and 39. Rosettes, etc., pages 15 and 16.

PARIS TWISTS A BAND ABOUT HER BROW



The above is a boudoir band made of ribbon and lace. It is 14 inches long by 6 inches wide and is made on a net foundation. The band is tied in back with streamers.

Use 3½ yards of 1-inch ribbon for the 3 rows, rosettes and streamers. 2 yards of 1-inch lace is shirred and outlines the cap.



A sachet bag is an important item for the lady who is complete in her daintiness. The above measures 2 inches high and 7 inches in diameter: 1 yard of ribbon 1½ inches wide is shirred around the ribbon center of 4-inch diameter. 1 yard of the same ribbon is shirred in like manner for the bottom, and another yard used for the thickness. 2 yards of ½-inch lace is used, 1 yard around the circumference and 1 yard in the center. Buds decorate the top.



The above shows a powder case open, and underneath it the same case closed. It is unique in its workmanship and an important asset: 10 inches of 4½-inch ribbon is attached to a hoop on top and another for bottom, both 9 inches in diameter. In order to close, the top and bottom are turned in opposite directions, and folded into the closed shape illustrated. Buds decorate the top.



The hair dress is equally as important as the evening gown to bring alluring charms to Milady. The band above is especially attractive and may be used for all dress-up occasions. 2½ yards of metal ribbon is used for the entire band; 6 blossoms decorate it, each requiring 10 inches of two-tone ribbon.



A vanity case as illustrated above is very attractive and conveniently carried about: ½ yard of 2-inch ribbon is used for the top. A tiny hem through the top allows for a draw string. A mirror of 4-inch diameter is pasted to a cardboard box 1 inch high. The mirror forms the base of the bag and the 2-inch ribbon is shirred around the circumference of the mirror and extends to form the thickness of the bag.



The hair band above illustrated is quite the thing for evening wear. It is made on a wire foundation bound with ribbon. 36 wheel-like motifs are arranged on the foundation and overlap each other, each wheel requiring 4½ inches of metal ribbon.



Hair bands are again in vogue and they are necessary items in adding completeness to the evening dress. The leaves and buds are easily made and add bloom and youth to the wearer. 34 leaves and 4 roses decorate the band above. Each leaf requires 4¼ inches of ribbon 2 inches wide, and 8 inches of ribbon is required for each rose. The leaves and roses are arranged on the wire foundation to fit the head size.

*Dainty Buds and Flowers are easy to make. For directions, see pages 38 and 39.*



BABY ACCESSORIES TO INSTILL ORDER AND COMFORT



A little coatee made of satin ribbon is attractive. The one above requires 2 yards of satin ribbon 9 inches wide for the top, and 3 yards of 6-inch ribbon for the lining; 2 yards of baby ribbon for the shirring. Rose-buds and streamers of 1/2-inch ribbon decorate the front.



A cap easily made is shown here. It requires 2 yards of 5-inch satin ribbon. Six yards of baby ribbon are used for the shirring, and 1 yard of 1-inch ribbon for the tie bow streamers.

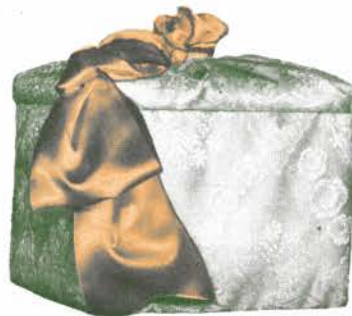

A ribboned box for her tiny bonnets is made of 3 1/4 yards of 8-inch ribbon as follows: 1 yard for the box, 1 yard for the cover shirred to a point and tied in a knot at the top; 8 inches for square covering bottom, and 32 inches to line the box. 3/4 yard of 4-inch ribbon which is rolled around the knot at the top forms the loop and streamer.



Little feet require little material, and on that account little expense and effort are required to make these booties. 1 yard of 6-inch ribbon is used for the booties, 3 yards of 1/2-inch baby ribbon for the shirring, and 3 yards of 1 1/2-inch ribbon for the binding.



Simplicity and comfort is portrayed in the workmanship of the long kimono made of cashmere and bound with ribbon. 1 1/2 yards of 1 1/2-inch ribbon is used for the front, 3/4 yard for the neck and the tie bow, and 8 inches for each sleeve. Feather stitches of white outline the ribbon trimmings.



The comfy jacket speaks for itself. To make it, use 1 yard of satin ribbon 9 inches wide, lined with 2 yards of 4 1/2-inch satin ribbon. For the shirring 10 yards of 1/4-inch ribbon are required, and the collar takes 1/2 yard of the 4-inch ribbon. 1/2 sheet of wadding is needed for the inter-lining.



Pad a wooden hanger with wadding or other material, then cover with 1 yard of 3-inch ribbon for top and bottom to fit shape of hanger. 10 yards of baby ribbon are required for trimming; 1/2 yard wound around the handle and a large knotted rosette at bottom of the handle. 15 streamers are made, varying in size, each knotted at the ends.



Another hanger with metal hooks is made as follows: 7 yards of 1 1/4-inch ribbon rolled around the bar. 1 yard of 1-inch ribbon for the handle and 1/3 yard for each flower. 3 inches of baby ribbon for each bud. See pages 38 and 39 for the directions in making buds and flowers. Also see diagrams to the left for covering hanger. Metal hooks may be inserted in a wooden frame.



Method of covering round bar with ribbon.

LITTLE THINGS OF GREAT IMPORTANCE

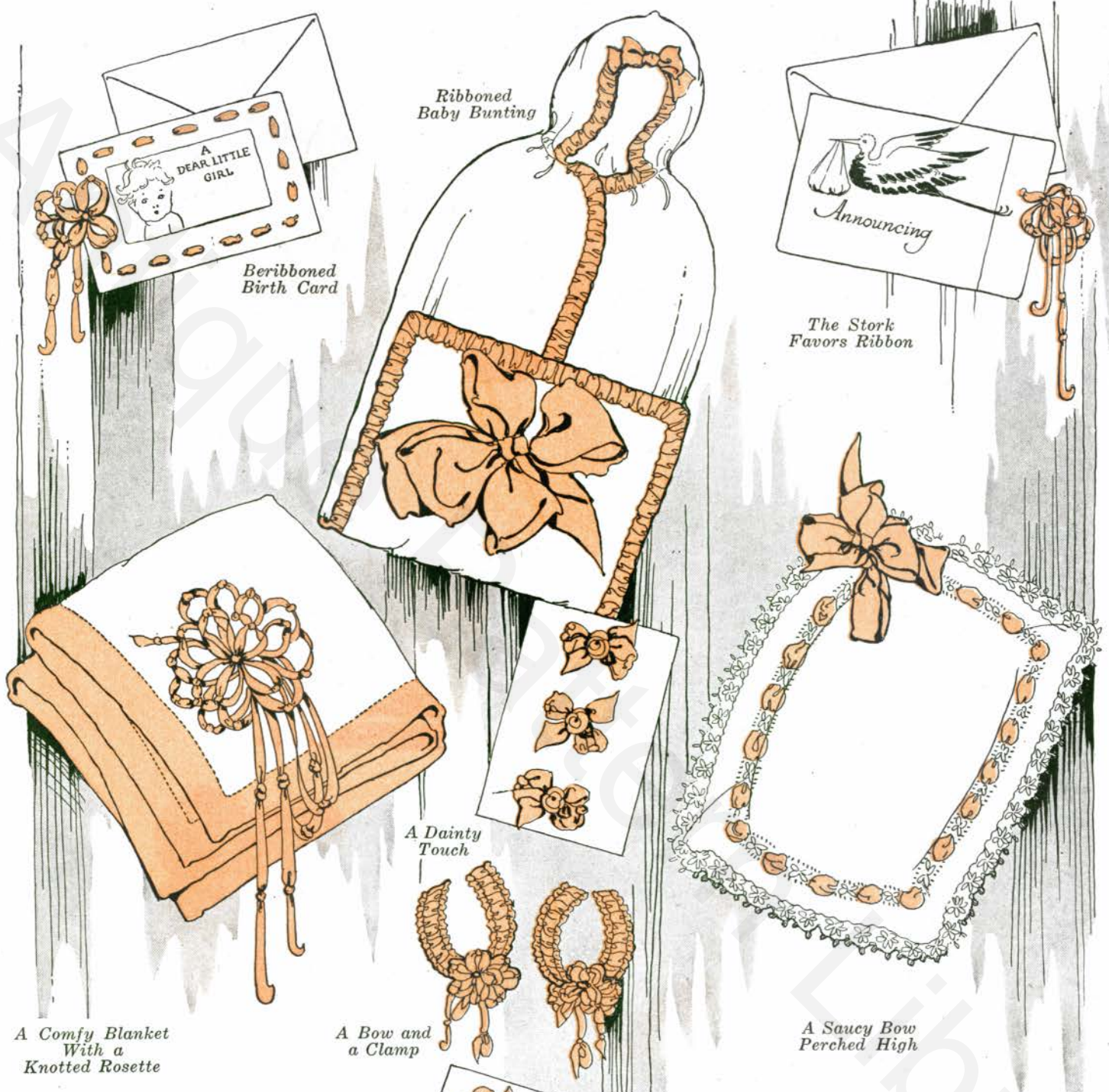

Ribboned Baby Bunting

Beribboned Birth Card

The Stork Favors Ribbon

A Dainty Touch

A Saucy Bow Perched High

A Comfy Blanket With a Knotted Rosette

A Bow and a Clamp

For Tiny Socks

Garter Charm

Little announcement cards must be trimmed with ribbon to fully express the glory of the occasion. Small bows and streamers as illustrated above are the proper fashion.

4½ yards of 2-inch satin ribbon is shirred and binds the baby bunting. 2 yards of 5-inch satin ribbon is used for the 5-looped bow, each loop measuring 12 inches and streamer 9 inches. ½ yard of 2-inch ribbon makes bow on hood.

The rosette on the comfy blanket has 20 loops of ½-inch ribbon, each 7 inches long, knotted in the center for artistic effect. There are two longer loops and 2 long streamers. The blanket is bound with 2½ yards of 1¾-inch ribbon.

The 3 tiny bows above are fastened to a safety pin and adjusted wherever necessary. For each bow use 10 inches of ribbon ¾-inch wide, and 2 inches of ¼-inch width for the tiny bud in the center.

The pillow case above is the regulation size. It is trimmed with ribbon and lace. 2½ yards of 1½-inch figured ribbon is drawn through the insertion and ¾ yard of the same ribbon is made into a bow.

Clamps decorated with ribbon help to trim up baby's carriage. The pair above require 1 yard of 1½-inch satin ribbon shirred to fit the clamp. The knotted rosette on each clamp requires 1½ yards of ¾-inch satin ribbon.

Side garters for the tiny mite are not complete without a dainty bow. The ones illustrated on this page require ½ yard of ½-inch ribbon for the 2 bows. 1½ inches of blue baby ribbon is formed into tiny buds for both garters.

Baby's socks have to be kept in place to develop the habit of neatness. The garters to the left require 1½ yards of ½-inch ribbon stitched together for elastic. 1½ yards of baby ribbon forms the rosettes for both garters.

(See pages 15 and 16 for Directions on Bows, Rosettes, etc.)

## CONCERNING BASSINETTES AND BASKETS



This charming pillow fits the bassinette illustrated to the left, and the following is the yardage for regulation size.

12 yards of 2-inch satin ribbon for blocking, and 3 pieces of baby ribbon for shirring which outlines each block and also decorates the lace.

3 yards of 3½-inch lace shirred, and 3 yards of 3-inch ribbon under the lace ruffle.

1 yard of 6-inch ribbon in 2 strips for lining of pillow.

The bottom of the bassinette requires a pad 32 by 16 inches. Yardage used:

10 yards of 3-inch ribbon for the blocking of pad, with 1 sheet of wadding for padding, lined with 2¾ yards of 5½-inch ribbon.

10 yards of 5¼-inch ribbon shirred for sides of carriage, padded with 3 thicknesses of wadding.

50 yards of baby ribbon for shirring which outlines blocks on pad, on lace trimmings, and on seams.

8 yards of lace, 3½ inches wide, gathered to fit hood and circumference of carriage, and 8 yards of 3-inch ribbon gathered under it.

2½ yards of 5½-inch ribbon for 6-looped bow, each loop 7 inches.



A round basket for Baby's small things is a necessity. The top diameter of the basket measures 16 inches, and the bottom 12 inches. There are 2 pockets and 2 pincushions which serve both useful and decorative purposes. The following materials are necessary to work the basket:

4 yards of 4-inch satin ribbon shirred for lining sides.

6 yards of 2½-inch ribbon for blocking the pad and 2 yards of wadding for padding.

30 yards of baby ribbon for shirring to outline the blocks on the pad and to decorate the lace.

8 yards of 2½-inch ribbon for plaiting at the top.

3 yards of 1¼-inch ribbon to line the handle.

7 yards of 1-inch ribbon for plaiting on either side of handle and 7 yards of lace 1½ inches wide gathered over plaiting.

2 yards of lace for trimming and ⅓ yard for each tiny bud is used for the cushions and pockets.



There are four compartments in this bureau; the floor of each is decorated with a pad of latticed ribbon, trimmed with shirring of baby ribbon. The top drawer is lined with ribbon, over which is placed a lace ruffle. The inside of the top cover is decorated with lattice work in the same way as the floors of the other compartments.

2 bows, each requiring 2½ yards of 5½-inch ribbon, are used for the top and side of the bureau.

*For details of Bows, see pages 15 and 16. For Lattice Work and Shirring, see page 40.*

BLUE FOR THE BOY—PINK FOR THE GIRL



A bonnet for the tiny Miss, cheaply and quickly made, is illustrated to the left:

1 yard of 8-inch Jacquard ribbon of contrasting color is used for the hat. 9 inches of the ribbon is gathered for the crown, and the remaining  $\frac{3}{4}$  of a yard is cut lengthwise and stitched together, making  $1\frac{1}{2}$  yards shirred to required size for the brim.

$4\frac{3}{4}$  yards of  $1\frac{1}{2}$ -inch figured satin ribbon is used for the knotted band, rosettes and streamers.



Covers made of eiderdown are warm and are made for Baby's comfort, but when trimmed with ribbon they become beautiful as well. The cover is  $\frac{3}{4}$  of a yard wide and  $1\frac{1}{8}$  yards long, including the pointed lap-over of 9 inches:

$3\frac{1}{4}$  yards of 2-inch satin ribbon is used for the band to outline edges and 3 yards each of 1-inch blue ribbon and  $\frac{3}{4}$ -inch pink are used for the narrower bands.

3 yards makes the 6-looped bow with 9 inches allowed for each of the streamers.

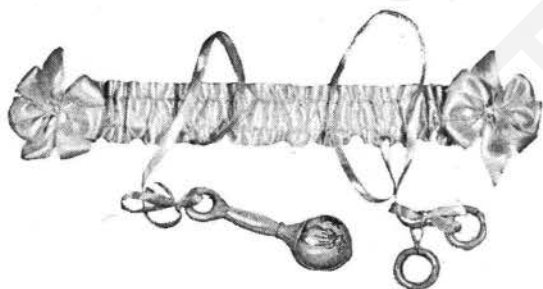

A carriage clamp made of ribbon with some little toys fastened to it is decorative, joyful, and provides for safety:

$1\frac{1}{8}$  yards of ribbon cut in half is sewed together lengthwise (see page 17, Diagram III), allowing  $\frac{1}{2}$  inch top and bottom for ruffling. Pull  $\frac{3}{4}$ -inch elastic through opening.

$\frac{1}{2}$  yard of  $\frac{3}{4}$ -inch ribbon is required for each of the bows, and  $\frac{3}{4}$  yard for each of the 2 streamers on which a rattle and teething rings are fastened. Clamps are securely stitched on to both sides.

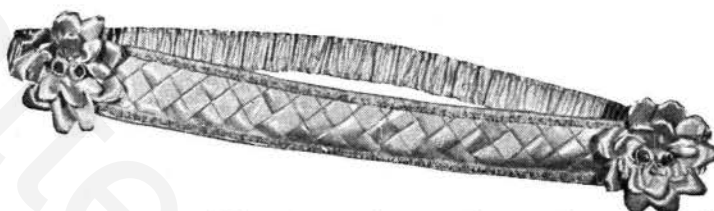

The pretty carriage strap is part of an exquisite layette illustrated elsewhere in the book:

5 yards of  $\frac{3}{4}$ -inch ribbon is used for the lattice blocking. (See page 40.)

3 yards of baby ribbon is shirred and outlines each edge.

$2\frac{1}{2}$  yards of satin ribbon 1 inch wide for the rosettes, and 2 yards of  $\frac{3}{4}$ -inch for the 4 roses, with same amount for leaves.

$\frac{1}{2}$  yard of  $2\frac{1}{2}$ -inch satin ribbon is folded lengthwise, stitched together and used for the back of the strap,  $\frac{3}{4}$  yard of elastic, 1 inch wide, is pulled through.



The scales are a most essential part of a baby's layette, for they tell a story of health and joy. To make the scale illustrated, the following materials are necessary:

A separate pad of lattice work fits into the scale, for which  $2\frac{1}{2}$  pieces (25 yards) of 1-inch ribbon is necessary for the lattice, 2 yards of 4-inch ribbon for the lining of the pad, 1 yard of wadding for the pad. (See page 40 for lattice.)

The sides of the scale are padded with lamb's wool and 1 piece of 4-inch ribbon is folded in  $\frac{1}{4}$ -inch plaits and used to decorate the inside. The ends of the plaiting, wherever too wide, lap over the sides of the scale.

4 yards of  $1\frac{1}{2}$ -inch lace and 4 yards of 1-inch insertion are sewed together and gathered to fit around the basket; the lace is decorated with 1 piece of shirred baby ribbon.

6 yards of 4-inch ribbon is plaited and used under the lace.

14 rose rosettes are used to decorate the top of the lace ruffle.



The important tiny hot-water bottle requires:

$1\frac{1}{4}$  yards of 2-inch satin ribbon which is shirred to fit around the ribbon covered oval cardboard  $2\frac{1}{2}$  by  $1\frac{1}{2}$  inches. (See diagrams to the left.)

$\frac{1}{3}$  yard of 5-inch ribbon is used for the back of the bag and  $1\frac{1}{2}$  yards of baby ribbon for the two draw strings.

$2\frac{1}{2}$  inches is turned in for the top hem and opening for draw string.

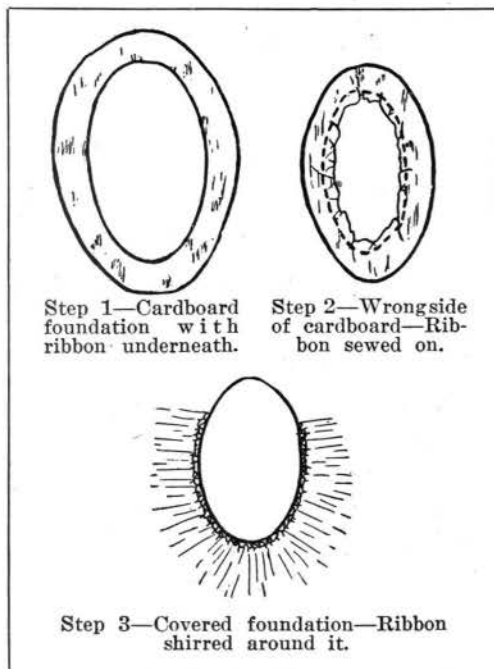

Bows and Rosettes described on pages 15 and 16.

# RIBBONS THAT BIND ONE TO YOUTH

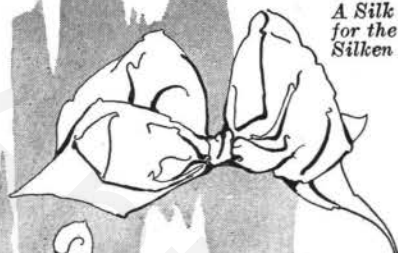

A Silk Bow for the Silken Locks

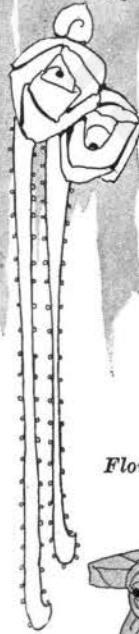

The little school-girl, the confirmation girl, and the sweet girl graduate,—make life joyous for them. They want to look and feel their best. Ribbons help them.

Flowing Streamers Charm the Little Miss

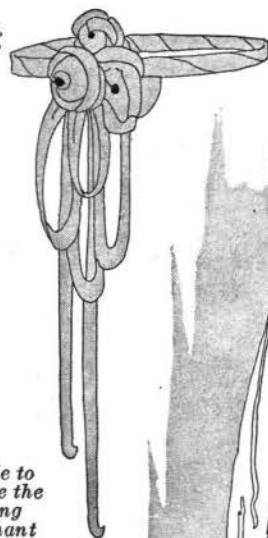

A Girdle to Encircle the Charming Confirmant

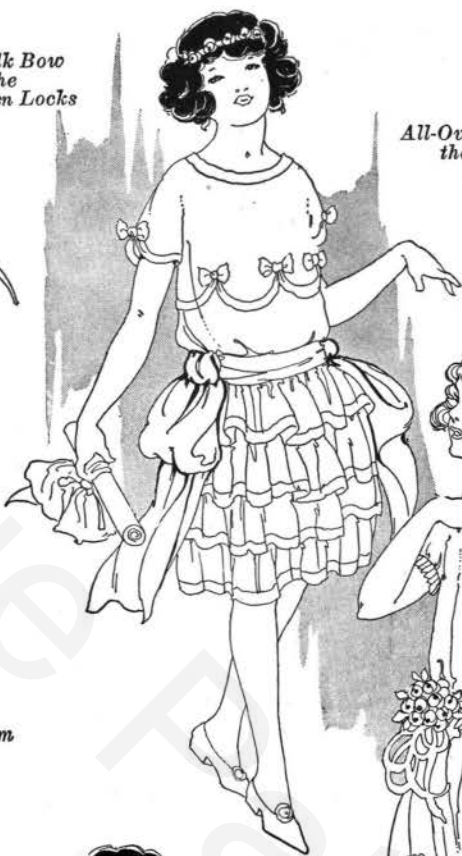

All-Over Ribbon for the Successful Graduate



The Bonnie Ribbon Hat



Seven-Looped Bow with Buds and Streamers



Wheels and Buds of Dainty Ribbon



Even Through the Crowning Veil—Ribbons

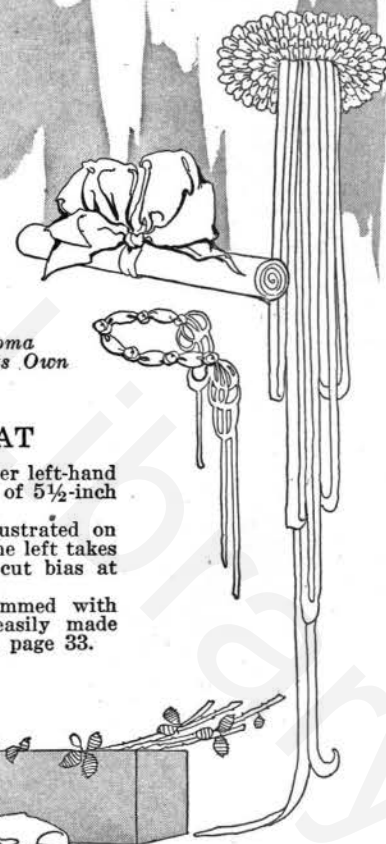

The Diploma Claims Its Own

## RIBBON CHAT

The hair bow in the upper left-hand corner requires 1 1/4 yards of 5 1/2-inch ribbon.

A sash like the one illustrated on the confirmation dress to the left takes 3 yards of 9-inch ribbon cut bias at the ends.

The dress above is trimmed with charming wheel motifs, easily made and described in detail on page 33.

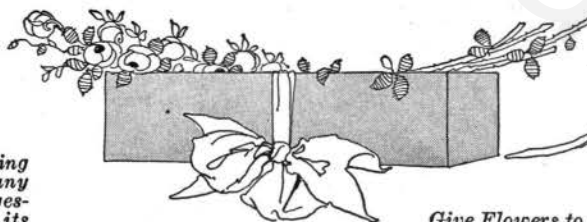

Give Flowers to the Fair—and Tie with Ribbon Bow

The "Ribbon Art" book offers hundreds of attractive articles for wearing apparel and household decorations. Color schemes are suggested in its many pages of colorful and fascinating illustrations. There are beautiful suggestions for the whole family. Lessons in interior decorating are given in its many pages of household charms. Keep a book always within your reach and be prepared for the unexpected party, or for any occasion which calls for an extra touch.

See pages 15, 16, 38 and 39 for useful suggestions in making Bows and Flowers

NEGLIGEEES OF LURING LOVELINESS



The simple but effective negligee illustrated above is trimmed with 4-inch satin ribbon which is gathered through the center as on page 40, diagram 1. 4 yards of the ribbon is used for each sleeve, 2 yards to outline the neck twice, and 4 yards for the bottom. The boudoir cap is illustrated and described on page 3, and the slippers above.



For the pair of slippers above, use:  $\frac{2}{3}$  yard of 4-inch ribbon for front, and the cut away pieces for back (see page 48), 2 yards 2-inch ribbon rolled to trim tops and  $\frac{2}{3}$  yard sewed together lengthwise for elastic. Decorate with buds.

The slippers to the right require:  $1\frac{1}{2}$  yards 5-inch ribbon. A  $\frac{1}{8}$ -inch hem is made on top and  $\frac{1}{16}$ -inch tuck below it gathered slightly to form the shape of the slipper. 8 inches is cut lengthwise in half and used for the plaited fancy. 6 inches makes each bow.



The practical negligee above is bound neatly with  $1\frac{1}{2}$ -inch ribbon. 8 yards are required:  $1\frac{1}{4}$  for neck and streamers,  $1\frac{1}{2}$  for front, 2 yards for sash, and  $1\frac{1}{4}$  yards for sleeves. Pockets are made of ribbon buds.



$6\frac{1}{2}$  yards 1-inch ribbon binds top, sleeves, and waistline of negligee; and 1 extra yard for streamers. Cap is illustrated on page 3 and slippers to the left.

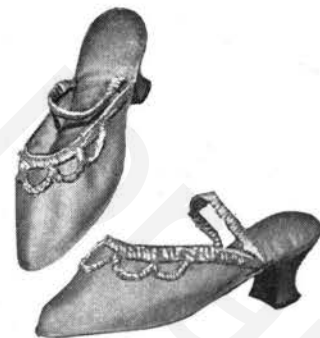

The slippers require  $\frac{3}{4}$  yard 4-inch ribbon. 1 yard  $\frac{1}{2}$ -inch ribbon for elastic (see page 17, Diagram I), and 4 yards for trimming.



Above slippers require:  $\frac{2}{3}$  yard 5-inch ribbon,  $1\frac{1}{4}$  yards of  $\frac{1}{2}$ -inch ribbon for elastic (see page 17, diagram 1). Trim with petal-like fancy and bows.

The exquisite negligee above is made of Georgette and trimmed with 25 yards of  $\frac{1}{4}$ -inch ribbon. Dainty buds in circles further decorate the whole. (For head band, see page 5.)

Bows are illustrated and described on pages 15 and 16. Buds and Flowers, pages 38 and 39

## RIBBON RUNS ITS SILKY WAY THROUGH NEWEST UNDERTHINGS



The camisole illustrated to the left requires 6½ yards of 1-inch ribbon, forming three bands across the cover, stitched together with fagotting. The front bands are latticed (see page 40). 1 yard of the ribbon is used for the shoulder straps and 1½ yards of 1-inch lace for the top.



For the camisole to the right use 7 yards of 2-inch figured ribbon and 1 yard for the straps. Buds decorate the top and the tiny bow is placed on the shoulder. Elastic is inserted at the bottom.



The camisole below, to the left, is trimmed with ¼-inch picot-edge ribbon with double shoulder straps, and a looped bow, requiring 1½ yards of ribbon.

Step-ins to match camisole require 1½ yards of ribbon for each bow and the same amount for binding each leg.



Practical Combing Jacket trimmed with Shirred Ribbon and Ribbon Flowers.



The latticed top for camisole requires 17 yds. of ½-inch ribbon. (See page 40 for lattice work.) 1 yard 3-inch ribbon for foundation.

The ruffle of the bloomers to the right is decorated with ⅜-inch picot-edge ribbon. ¾-yard is used for each rosette.



The brassiere above is bound with 1-inch satin ribbon on top and bottom. The straps are made of the same ribbon. About 2¾ yards of ribbon is required.

Step-ins with Pointed Edge of Ribbon.

See pages 38 and 39 for your choice of Buds and Flowers; for making Bows, pages 15 and 16

## BEGUILING NEW MODES IN LINGERIE



*Ribbon  
Neatly  
Applied*

The chemise to the left requires  $1\frac{1}{4}$  yards of 1-inch ribbon for each of the 3 bands across the top. One yard is allowed for the shoulder-straps and 2 yards to bind the bottom. Decorate with buds.

The tailored gown needs a touch of ribbon. One yard is used for the top.  $1\frac{1}{2}$  yards are drawn through the slits, and  $1\frac{1}{2}$  yards for 2 rows of ribbon used on each shoulder-strap. Allow  $\frac{3}{4}$  yard for tailor-made bows.

The camisole is made of 7 rows of  $1\frac{1}{4}$ -inch figured ribbon sewed together. Each row requires  $1\frac{1}{4}$  yards. One extra yard is used for the straps. Buds decorate the front.



*A Negligee Favored  
by Buds*

The negligee to the left favors ribbon buds for trimming. 6 inches of 1-inch ribbon is used for each bud. 3 yards are required for the waistline, 1 yard rolled around waist and the rest for streamers.



*Gown and  
Camisole  
Compe*



*A Real Feminine Pride*



Double rows of taffeta ribbon separate into scallops on the effective georgette chemise to the left. The step-ins are similarly decorated.

The camisole above requires  $11\frac{1}{3}$  yards of 1-inch Jacquard ribbon for each of the 4 rows which trim it. 1 yard is used for shoulder-straps.

The chemise to the right requires  $\frac{3}{4}$  yard of 1-inch ribbon to enclose each of the lace circles, 1 yard for the top and 2 yards for the bottom and 1 yard for each of the double shoulder-straps.



*Lace and Ribbon Unite*

For detailed descriptions of Buds and Flowers see pages 38 and 39; for Rosettes see pages 15 and 16.



KNITTING & CROCHETING WITH RIBBON SHOW ORIGINALITY

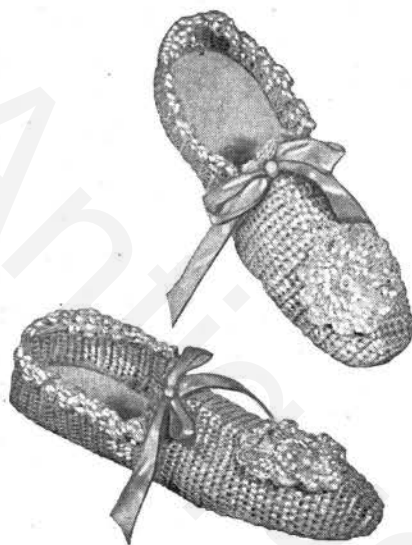

Crocheted bedroom slippers made of narrow baby ribbon are smart and practical. A crocheted fancy of the same ribbon trims the slippers, and ribbon  $\frac{3}{4}$ -inch wide is pulled through the top.



The above sleeveless sweater was originally worked in pink and gray baby ribbon, shaded to give a two-tone effect. The result was charming.



A handy bag made of baby ribbon with a tassel of the same is attractive.  $\frac{2}{3}$  yard of 8-inch ribbon lines the bag.

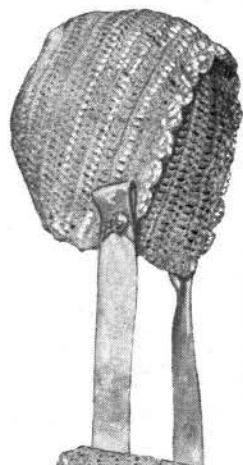

Narrow baby ribbon is crocheted to make an attractive bonnet like the one illustrated to the left. Pink, blue, and white are baby's own colors, and any one of them may be employed in working the cap.  $\frac{1}{2}$  yard of  $1\frac{1}{2}$ -inch satin ribbon is used for each streamer.



A knitted tuxedo sweater of narrow baby ribbon is all that one can wish for in originality and neatness.

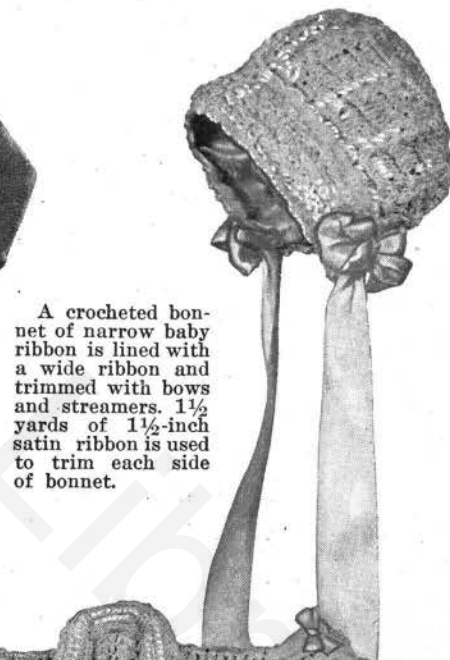

A crocheted bonnet of narrow baby ribbon is lined with a wide ribbon and trimmed with bows and streamers.  $1\frac{1}{2}$  yards of  $1\frac{1}{2}$ -inch satin ribbon is used to trim each side of bonnet.



Baby ribbon forms a crocheted coatee. It may be made of pink, blue, or white baby ribbon, and the picot edge would add a charming finish if worked in a contrasting color. 1 yard of 1-inch ribbon is used at the neck tied into a dainty bow when worn.

To make knitted or crocheted articles of baby ribbon, follow the directions ordinarily used for wool or floss, with the exception that fewer stitches are required.

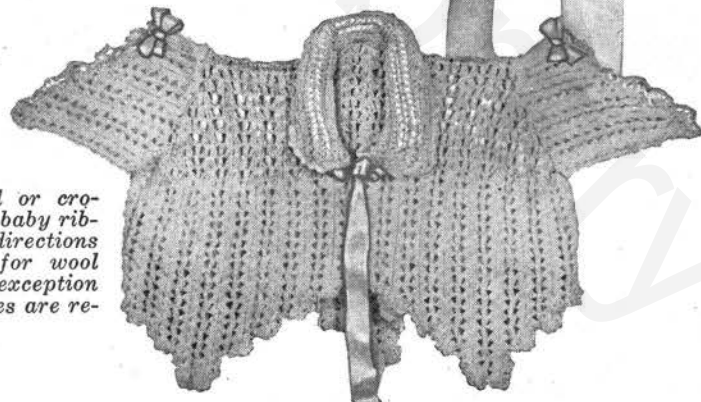

The charming sweater of odd shape is also for baby and is made of narrow baby ribbon. Ribbon 1 inch wide trims sleeves and neck.

THE VOGUE FOR BOWS AND ROSETTES

**A**

24 inches of 6-inch ribbon is used to make the shirred loop buckle through which the upper loops of this bow are drawn. Five 1/4-inch tucks are evenly spaced on the ribbon, as in Fig. 1, and a milliner's wire drawn through each tuck, as in Fig. 1. After the ribbon has been evenly shirred, all the five rows of wire are connected and gathered together, as in Fig. 2. Four loops of ribbon are laid, bow fashion, and a knot tied in the center, the two upper loops being drawn through the center of the buckle.

**B** *Hair Bow*

Diagram 3 indicates the manner in which the ribbon is laid for this simple Hair Bow. The one end is utilized to form the loop for the center. When this loop has been pulled tightly, the two ends are knotted in the back of the bow to hold it securely, as in Fig. 4.

**C**

Six loops and two ends are arranged as in Fig. 5. These are tied with a separate piece of ribbon as in Fig. 6.

**D**

One end and a loop, as in Fig. 7, are wound with several strands of thread to hold them securely. Five additional loops are each fastened in the same manner, as in Fig. 8. The remaining end of ribbon is drawn between loops three and four, and is knotted on the reverse side, as in Fig. 9, the remaining end being cut the same length as the first end. Both ends are cut on the bias.

**E**

*Knotted Bow*

Two knots are placed in a short piece of ribbon, as in Fig. 10. The knots are placed in the center of two loops, which are held firmly by tacking. A rosebud covers the tacking.

# KNOTS AND LOOPS THAT PARIS DECREES

**A**

A—The Bob Bow is a decidedly novel arrangement for wear with bobbed hair. There are 12 loops of 4 or 5 inch ribbon, with a knot centered in each loop. Each loop must be of equal length, but may vary from 6 to 10 inches, depending wholly upon the size of the bow desired. As indicated in Fig. 1, a small tuck is made across the ribbon, at intervals of 6 to 10 inches. A knot is made between the first and second tuck, as in Fig. 2. When, as in Fig. 3, 13 of these tucks are made a wire is run through them. The two ends of the wire are bent into a hook. Two ends finish the bow.

**B**

B—Is a Regulation Hair Bow, requiring from 1¼ to 1¾ yards of ribbon. It is made like the regular tailored bow, excepting that the knot in the center is drawn tightly and tied in the back. Details of a plain tailored bow indicated in Figs. 5 and 6. Tightened to shape a hair bow shown in Fig. 7.

**C**

C—This tailored bow is very simple to make. The ribbon is laid in folds as indicated in Fig. 8. A circle is cut into the last end of ribbon, as in Fig. 9. The upper loops are drawn through it and the end of ribbon is plaited and fastened on wrong side. The ribbon following circle is laid in plaits and tacked back, covering the circle and making a simple but effective finish for the center, as illustrated in Fig. 10.

**D**

D—Rosette with knotted loops and ends. These can be made of any width ribbon, with the number of loops and ends varying from 4 to 40. When the length of the loops is determined upon, a knot is placed in the center of each one, as in Fig. 11. The loops are then folded and placed alternately to the right and to the left, and tied with a knot in the center. The ends may be knotted, or looped and knotted, as desired.

**E**

E—Whether the ribbon be wide or narrow, and the desired loops number 3 or 10, this rosette is simple to make if one but runs the needle diagonally across the ribbon as in Fig. 12, and gathers into a tight shirring. The center of the above rosette is made of very narrow ribbon, gathered into four loops in the same fashion.

“A RIBBAND FOR THY GARTER”

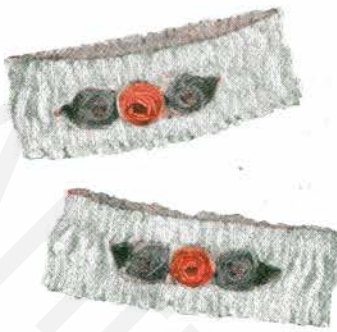

The above garters require  $1\frac{1}{8}$  yards of 2-inch figured ribbon for the foundation,  $2\frac{2}{3}$  yards of  $\frac{1}{2}$ -inch satin ribbon for the under side of garter; allowing  $\frac{1}{4}$  inch on each side, sew as in Diagram II. Decorate with 3 buds.

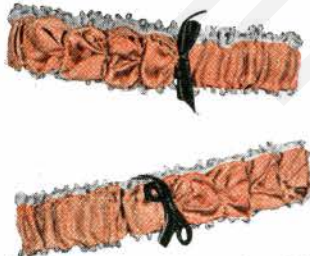

These garters are made with 1 yard of  $1\frac{1}{2}$ -inch 2-tone ribbon, and the same amount of 1-inch ribbon of contrasting color, sewed as in Diagram I. Decorate with 4 petals and bow.

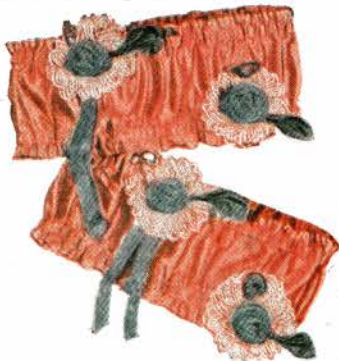

Use  $1\frac{1}{4}$  yards each of 2 contrasting colors of 3-inch double-faced satin ribbon. Sew as in Diagram II. 8 inches of lace is made into wheel fancy, and with buds and streamers decorates each garter.



Take 1 yard of  $1\frac{1}{4}$ -inch picot-edge ribbon for foundation, and same amount of 1-inch contrasting color for under side. Sew as in Diagram I. A spiral loop, buds, and streamers trim each garter.



The cockades on the slippers above require: 1 yard of 1-inch grosgrain ribbon. Make  $\frac{1}{4}$ -inch plaits, forming wheel of 3-inch diameter. 2 streamers  $2\frac{1}{2}$  inches long trim each cockade. A metal buckle is placed in center.



These simple garters are made of  $1\frac{1}{4}$  yards of  $1\frac{1}{2}$ -inch grosgrain ribbon and 1 yard of 1-inch colored ribbon, sewed as in Diagram I. Decorate with large plaited wheel, another small one of contrasting color, and a tiny metal buckle.



Diagram I.—Ribbon of Different Widths. Narrower Ribbon Placed to Form Right Side or Under Side.

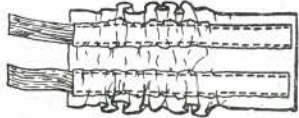

Diagram II.—Under Side, Showing Ribbon Placed for Narrow Elastic on Top and Bottom.



Diagram III.—Ribbons of Same Width. Allow for Ruffling on Top and Bottom.



Above garters use  $1\frac{1}{4}$  yards of  $1\frac{1}{2}$ -inch satin ribbon, and 1 yard of 1-inch ribbon of contrasting color, placed as in Diagram I. 2-tone picot-edge ribbon 1 inch wide is braided for trimming.



These garters require  $1\frac{1}{4}$  yards of  $\frac{3}{4}$ -inch ribbon for top and  $1\frac{1}{4}$  yards of  $\frac{1}{2}$ -inch ribbon for bottom, sewed as in Diagram I.  $2\frac{1}{4}$  yards of lace  $\frac{3}{4}$  inch wide gathered as illustrated. Decorate with bow.

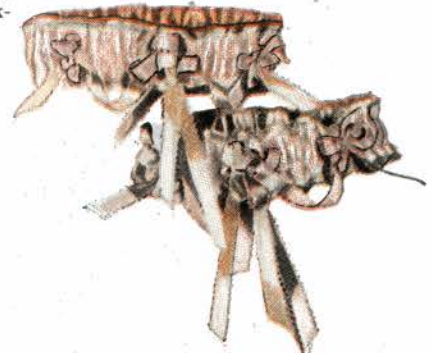

For garters above:  $1\frac{1}{4}$  yards each of 3-inch ribbon in contrasting shades for outside and lining of garters; see Diagram III. Decorate with bow-knots and streamers.



Use  $1\frac{1}{4}$  yards of 2-inch satin ribbon. Turn in one end, forming  $\frac{1}{2}$ -inch hem for elastic.  $1\frac{1}{8}$  yards of  $1\frac{1}{2}$ -inch lace on selvage. Buds and streamers further decorate garters.

For Choice of Buds, Flowers, and other Decorations, see pages 15, 16, 38 and 39. Directions given.

## RIBBON-BONS FOR PARTY FAVORS

A party is not complete without the proper decorations. Favors and gifts do not give the desired thrill unless tied in some secretive fashion with bands of ribbon. Whether a birthday, shower, or any other glorious occasion, the ribbon adds the final touch. It knots the tie of good will. The decorations pictured on this page were designed to beautify all happy occasions and the articles can be easily copied. All bows, rosettes and flowers are minutely described on pages 15, 16, 38 and 39.



Nothing could be more tempting. The glasses and plates are proof that hunger and thirst will be satisfied; and the basket of flowers adds a natural charm. But the beauty of effect would not be complete without the streamers of ribbon.



It may be a birthday, or a wedding, or a shower. All of these happy occasions could be celebrated with a table set as above. The ribbons branch off in streamers. The lamp shades are also made of ribbon, and everything seems to be favored with it.



A basket of flowers! It may be for the bride, or it may be someone's birthday. That we do not know, but it is certain that something unusual is taking place, for see all the ribbons! Frills on the basket, more streaming from Cupid's neck, and a great big wing bow at his belt. Even the flowers may be made of ribbon and kept forever as a reminder of the day. (See pages 38 and 39.)



Cupid is announcing himself and is sure to be admitted because he is so prettily dressed up with ribbon.



Even bonbons are made sweeter by ribbon bows.



Kerchiefs tied with ribbon.



Even on a lamp—she loves ribbon.



Guess what is hidden under these charming buds and ribbons. A box of powder, to be sure!



Many boxes for Milady, but none complete without the bow of ribbon. What joy and expectancy as with trembling fingers she unfastens the silken knots.

## ORIGINAL FANCY DRESS COSTUMES

"Now, just what am I going to wear?" A solved question and a sure "Blue Ribbon" for the masqueraders who adorn themselves in one of these costumes. Which is yours for the coming "affair"?



"All work and no play makes Jack a dull boy." What joyful memories of our past parties, and masks, and the "heaps of good fun"! You remember the Blue Ribbon was given to the ancestor of Blue Ribbon itself—the Ribbon Masquerader. Ribbon has a charm,—a softness, a joyous air of festivity. Little Bo-Peep to the left is amply supplied. Her rival who is near her is decorated with many flowing streamers. Even our gallant youth above looks more gallant with his ruffle of ribbon about the neck. The masquerader in the left corner adds womanly charm to her dignity by the feminine touches of ribbon and dainty bows; and such coquettish ends are worn by the dame above!

The above may be the prizes that our fair ribbon winners will receive to put a happy climax to their fun. A garter, a vanity bag, a pillow, a cupid doll, and boxes to test our curiosity. All made more decorative by the ribbon touches.

CUSHIONS THAT ADD TO COMFORT AND BEAUTY AT HOME

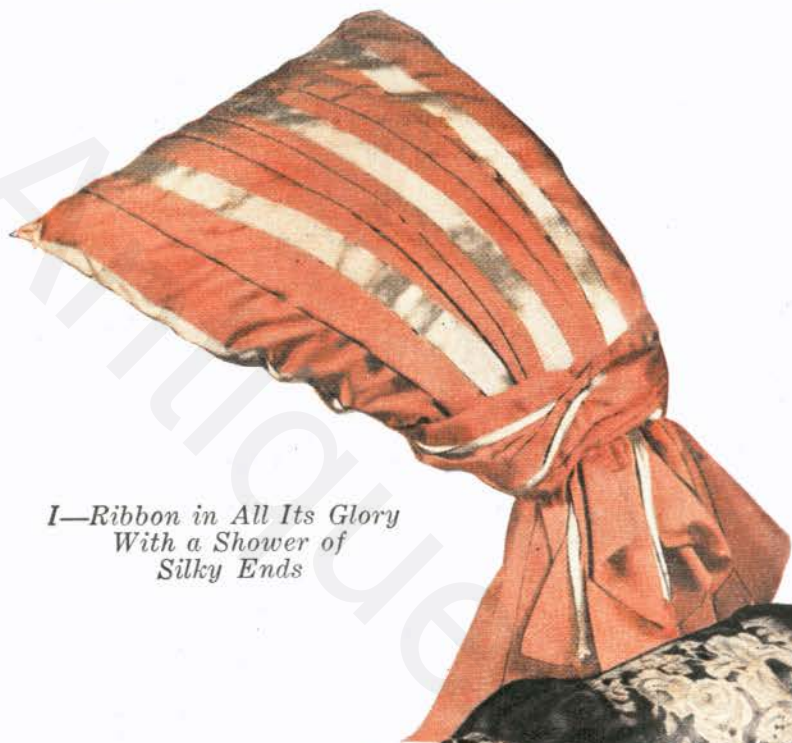

I—Ribbon in All Its Glory  
With a Shower of  
Silky Ends



II—  
Metallic  
Richness  
With  
Tassel  
Finish



III—Long Slender  
Lines Make Pillows  
Popular; Trimmings  
of Gold Are  
Attractive



IV—Shirring Gives Charm to This  
Round Pillow

No. V. A luxurious round pillow, 20 inches in diameter. 2½ yards of figured ribbon 7½ inches wide is shirred to fit the circumference.

2¾ yards of 1¼-inch velvet ribbon is latticed for the 6½-inch square, placed in the center. ¾ yard is used for each of the loops extending from the corners of the square.

5½ yards of 1½-inch velvet ribbon is plaited around the circumference and outlines the lattice square.

Trim with rose leaves and buds.



V—Roses, Streamers and Figured Brocade  
All Combine for Real Comfort

No. I made of plain ribbon combined with gold metallic ribbon. The cushion is 22 inches long and 18 inches wide, plaited to a width of 7 inches at one end.

7½ yards of 6-inch ribbon is used for the cushion: 4 strips, each 32 inches long, for the top, with one or two plaits in each piece to fit the required width. 3 strips are used for the back. There are 12 ends, each 8 inches long.

4 yards of 1½-inch gold metallic ribbon outlines the 3 sides and seams. An extra ¾ yard is used for 5 streamers and ¾ yard for the trimmings at the end.

No. II is a long cushion. It measures 27 inches long and has a 27-inch circumference.

1½ yards of 10-inch metallic brocade ribbon cut in 2 strips is used for the foundation of pillow.

3½ yards of 5-inch black satin ribbon is arranged in 3 bands which are shirred around the circumference. The 2 end bands are shirred at the outer points to fit a flat piece of ribbon with a 5-inch circumference, which is inserted at each side. Tassels of gold and black hang from the center of the inserts.

No. III is another round pillow which measures 27 inches in length and has a circumference of 27 inches.

1½ yards of 10-inch ribbon forms 2 bands, each 27 inches long, for the foundation. The ends are shirred to a 12-inch circumference, to fit around a ribbon fancy placed at either end. 1 yard of 10-inch ribbon is shirred to a 12-inch circumference at the top, tapering off to a point, forming the fancy. 1 yard is used for the 2 wings which decorate the ends.

4½ yards of gold braid is cut into 6 bands and placed around the circumference. ¾ yard of the braid is used around the top of the fancy and ¾ yard outlines the wings.

No. IV is ideal for comfort and beauty. It is 20 inches in diameter. 3 yards of 10-inch taffeta ribbon is shirred to fit the circumference and shirred also at the top to fit a 7-inch diameter.

1¾ yards is needed for lining the pillow. 4 strips are used. 2 yards of 1¼-inch picot-edged ribbon for each of the 4 groups of shirring, and an extra 1¼ yards to go around the center circle of 7-inch diameter.

## DECORATIVE IDEAS THAT ARE SMART AND PRACTICAL

**R**IBBONS long and short, ribbons wide and narrow, and tiny bits of ribbon, all join ends to make the world more beautiful. And what a complete transformation they do make—those silken threads of loveliness! Can you imagine the comforts which will reign in a home, decorated with the articles on this page? They are all made of ribbon. It takes little time to make them, and only a fractional part of the cost it would take to buy them. And then the complete joy of saying, "I made it."

Look through the pages of this unique and practical "Ribbon Art" book, so full of fascination, originality, and color. Choose the things you would love to have for your home or for your personal necessities. A store of real knowledge when mother's, sister's, or baby's birthday comes around.

All these occasions will be doubly thrilling if you take a hand in forming the little bows and knots. Make some of these things and enjoy the fun of it, and the satisfaction which true economy brings.

Beautiful lamps cast beautiful light. The above shade is 21 inches in diameter. There are four panels each, of the plain ribbon and the figured ribbon.

1½ yards of 9-inch jacquard ribbon and 1¼ yards of plain silk ribbon is used for the top of the shade.

2½ yards of 9-inch ribbon is used for the lining, shirred to fit the shape of the lamp.

6½ yards ½-inch gilt ribbon outlines the panels and top of the fringe.

3½ yards ½-inch satin ribbon to cover the framework. (See page 48.)

1½ yards double-faced ribbon for the extreme top, worked in honey-comb effect. (See Diagram 5, page 40.)

4½ yards of 4-inch colored fringe.



A paper basket of cardboard is easy to make. The floor of the basket is 4 inches square, and each side at the highest point is 14½ inches and at the bottom of point 12 inches. Each side has two points.

1 yard of 9-inch black satin ribbon is used for the lower half of the basket.

8 pieces of figured or novelty ribbon 9½ x 5 inches each, from point to point are used for the top.

5½ yards of ⅜-inch fancy gilt-edge ribbon binds the seams.

2½ yards of ½-inch black satin ribbon binds the sides and bottom.

Gilt net lines the basket, and the edges are all bound with ½-inch ribbon.



The runner to the left measures 60 by 18 inches; it will add dignity to any table. Materials required:

1½ yards of 7-inch figured or novelty ribbon cut in six triangles, the same pattern used for each insert.

1¾ yards of 7-inch black satin ribbon.

8½ yards of ⅜-inch figured gilt-edge ribbon to outline all the seams and panels.

4¾ yards of 8-inch satin ribbon for lining (3 strips).



Comfort and beauty combined are represented in this pillow. The background is black. It measures 21 inches square and requires:

1½ yards of 6-inch black satin ribbon and 1 yard of 7-inch figured or fancy ribbon for top of pillow, forming triangles.

2¾ yards of ⅜-inch fancy gilt-edge ribbon for outlining panels and seams.

2½ yards of 3-inch satin ribbon for sides.

1¾ yards of 8-inch satin ribbon for lining (cut in 3 strips).



SMALL—BUT OH, SO SMART!



1, 2, 3, 4—Four ribbon charms for the lassie's dress-up. The wheel-fancy with long, wide streamers and the smaller one with narrow streamers, will make beautiful finishing touches that may be worn on any of her dresses. And the wreath of ribbon wheels is a headband for her curly locks. The large bow tells its own story.



The butterfly does not really wish to get away from this charming little maid—with so many, many silken threads that he himself took a hand in manufacturing. Her dress, socks, and even her shoes have touches of alluring ribbons.

"I am the original little ribbon girl," is what she is undoubtedly telling us. It is self-evident of course.



What would the roses do without such little maids to carry them? Her ribbons are fresh as the roses themselves



All dressed up for her stroll! She likes ribbon added to give the "finis" to her clothes. The ribbon hat is described in detail on page 48.



The "Bow" days lend fascination.

Learn how to make your favorite Bows, on pages 15 and 16.

## THE RIBBON EDICT OF PARIS



Collar and cuff sets trimmed with dainty colored ribbon are much in demand, and the above is only one of the many possibilities for trimming small things. Baby ribbon in 2 contrasting colors is used. The same original touch may be added to vests, felt hats, simple dresses, baby things and details.



The neckpiece illustrated to the left is smart. It is made of ribbon. A foundation is made of 1 yard of 4-inch ribbon, and 13½ yards of 2½-inch ribbon is used in making the points, with 1½ yards allowed for the ends that tie in front.



A hat made of grosgrain ribbon is durable and may serve all occasions. The one illustrated here is made of 35 yards of ½-inch ribbon. The crown is made in lattice work (see page 40) and ribbon buds decorate the entire brim. Buds of this kind are easy to make, for it requires ½ yard of ribbon wound spirally around the center for each bud. (See page 38.)



The vestee with Peter Pan collar is made entirely of ribbon. 1¼ yards of 9-inch fancy ribbon makes the vest, and 1½ yards of 8-inch plain ribbon is used for Peter Pan collar. The opening at the neck is trimmed with blanket stitches of baby ribbon.



The coatee requires 5 yards of 1-inch ribbon which binds the front, armholes and pockets. The belt is made of the ribbon upon which a buckle is fastened.

The hat and sleeveless coat illustrated above form a most attractive sports outfit. The hat is made of 2 yards of 5-inch ribbon. The crown requires 1 yard shirred around an oval top 8 x 4 inches. 1 yard is required for the brim. The brim and crown are both shirred to fit the head size and then sewed together.

The neckpiece illustrated below has many loops and bows to add feminine charm to the wearer. It is made on a foundation of ½ yard of 2½-inch ribbon; 4¾ yards of 6-inch ribbon is required for the bows. The flowers and loops are made of 6 yards of 2½-inch ribbon, and the ends of 5½ yards of 1-inch ribbon.



An extra touch to the street dress or suit is found in this neckpiece illustrated above. 10 yards of 7-inch velvet ribbon is required to make it. 10 yards of ¼-inch picot-edge ribbon is looped around the 4 squirrel buttons. (See Wild Rose, page 48.)

For descriptions of Bows, see pages 15 and 16. Flowers and Buds are described in detail on pages 38 and 39.

## DAINTY GIFT SUGGESTIONS



Shoe trees neatly decorated with ribbon fit in with the rest of her carefully arranged wardrobe. 1 yard  $\frac{3}{8}$ -inch figured ribbon is used for each tree, and a rosette of 4 inches of the ribbon with 2 buds in the center further ornaments each of the trees.

WE all adore making pretty things—and why not? Have you only a little spare time? If so, you will find the suggestions in this book helpful, for some take little more than minutes to accomplish. Are you planning to remodel your home? Be your own interior decorator—there are all sorts of happy ideas for the home. Is there going to be a shower for your chum? Below is a dainty sachet bag that will find a ready nook in her hope chest. If you yourself are a bride-to-be, you will find all your expectations fulfilled for the decoration of your home, and for dainty additions to your hope chest. Birthdays, too, bring joy when you are able to make such a charming basket, or a screen, or shoe trees, as illustrated on this page.



The stately doll which serves her part in acting as a telephone screen is dressed with 5 yards of 9-inch ribbon to form the skirt and bodice. 7 yards of  $\frac{1}{2}$ -inch ribbon is plaited to form the decorative bands on the dress. See page 40 for plaiting.



The heart-shaped sachet bags require:  $\frac{3}{4}$  yard of 4-inch satin ribbon for each heart, sewed together with over-casting stitches of narrow baby ribbon.  $3\frac{1}{2}$  yards of  $\frac{1}{2}$ -inch 2-tone ribbon forms the loops and ends.  $\frac{3}{4}$  yard is used for the bud.



The basket above is decorative and useful. In the library or sitting-room it claims equal place with any of the furnishings, even though it is only a waste-paper basket. 4 yards of 9-inch changeable ribbon are used for the foundation. 5 yards of gold braid are required for the trimming. 5 yards of  $\frac{1}{2}$ -inch ribbon cover the framework (see page 48). 4 yards of plain ribbon 9 inches wide are used to line the basket.



Many rose petals make this attractive lamp-shield. 4 yards of  $\frac{3}{4}$ -inch ribbon is used, each petal 2 inches.  $\frac{1}{4}$  yard of 5-inch ribbon covers the frame (see page 48). For petals see below.

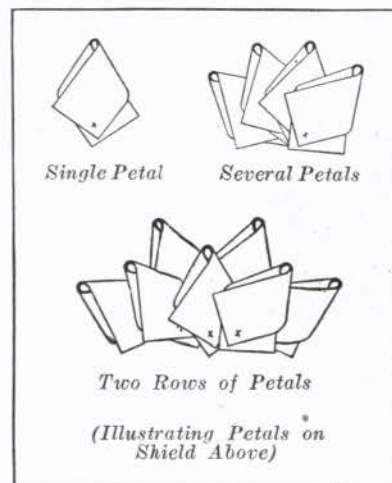

The screen above is useful and adds dignity and importance to the telephone. It is made of:  $\frac{1}{2}$  yard 7-inch ribbon for the center panel; 7 inches cut in half and used for each of the side panels. 10 yards of ribbon is used for the trimming.

## THE VOGUE DECREES THAT RIBBON DECORATE THE BOUDOIR



This pincushion is large and will be of great service to the needleworker because of the ample amount of pins and needles it may hold.  $\frac{1}{2}$  yard of 5-inch ribbon is used to cover the cushion, which is 4 inches long. 3 yards of  $\frac{3}{4}$ -inch ribbon is used for the braid which outlines the cushion. Buds and bows also decorate it.

FASHION demands a ribbon touch—from tiny tot to grandma. Baby's dainty accessories are not as charming without it. The little Miss finds her hair bow and her ribbon sash most important to her amateur coquetry. And the sweet girl graduate with quivering hand unties the ribbon bow from her diploma. The bride, too, finds herself entangled in streams of ribbon which help her shine forth in all her beauty and grace. Mother holds to youth by adding a ribbon touch to her garments, and even grandmother ties a bow on her new bonnet. The boudoir claims a goodly amount of it, for in her privacy Milady glories in the dainty touches that add color to her surroundings.



A pincushion that may also serve the part of a boudoir ornament is illustrated in the one above. The pincushion proper is circular with a flat base. It is covered with ribbon and stands on 3 metal balls. The dress and bodice are made of  $1\frac{3}{4}$  yards of 4-inch ribbon, and the bows of 1 yard of 1-inch ribbon.



The head band is made of 3 strips of ribbon each  $1\frac{1}{4}$  yards long: 2 strips of 3-inch ribbon, and 1 of  $\frac{3}{4}$ -inch metallic ribbon are braided. 2 yards of 1-inch satin ribbon are used for the flowers.



The sewing basket above is made of  $8\frac{1}{2}$  yards of moire ribbon 5 inches wide, which is gathered both inside and outside the frame. 5 yards  $\frac{1}{2}$ -inch satin ribbon to cover frame (see page 48). Fittings consist of ribbon, scissors, wax, emery, and thimble.



The doll forming the boudoir lamp is made of  $1\frac{1}{2}$  yards of 10-inch ribbon edged with 4 yards of gold lace. 5 yards of baby ribbon cover frame. Trim with buds.



A waste-paper basket like the above will serve even for scraps of the most sacred documents.  $3\frac{1}{2}$  yards of satin ribbon 9 inches wide are used for the outside and bottom. 2 yards of 6-inch ribbon for inside.  $1\frac{1}{2}$  yards of 1-inch ribbon for handles. Roses and leaves trim the basket.

For Buds and Flowers, see pages 38 and 39

## A PATH OF RIBBON LEADS TO THE ALTAR



“**H**ERE comes the bride.” And a charming and smiling one. It is an occasion of great joy and solemnity, and the little flower girls and bridesmaids are charmed, too—for there is an unusual beauty cast on everything. It might be because of the bride’s own beauty, but everyone is aware that it is not just that. There is something alluring, something fairylike, about the streams and streams of dainty ribbon that are flowing everywhere. The altar, the bride’s dress, and veil, and her headdress, too—all have this touch of feminine charm. And the wide-eyed little flower girl in her innocent loveliness, shines out from her entanglement of ribbons. The knots and loops on her bouquet add to the natural beauties of the flowers. All these soft and shining strips instill an air of confidence, for being led to the altar in silken fashion prophesies a straight and joyous path.

All these bows, knots, flowers, etc., are described in detail on pages 15, 16, 38 and 39, and you can make them for any of your parties—and add personal pride to the scene.

## FRENCHY TOUCHES FOR THE TROUSSEAU

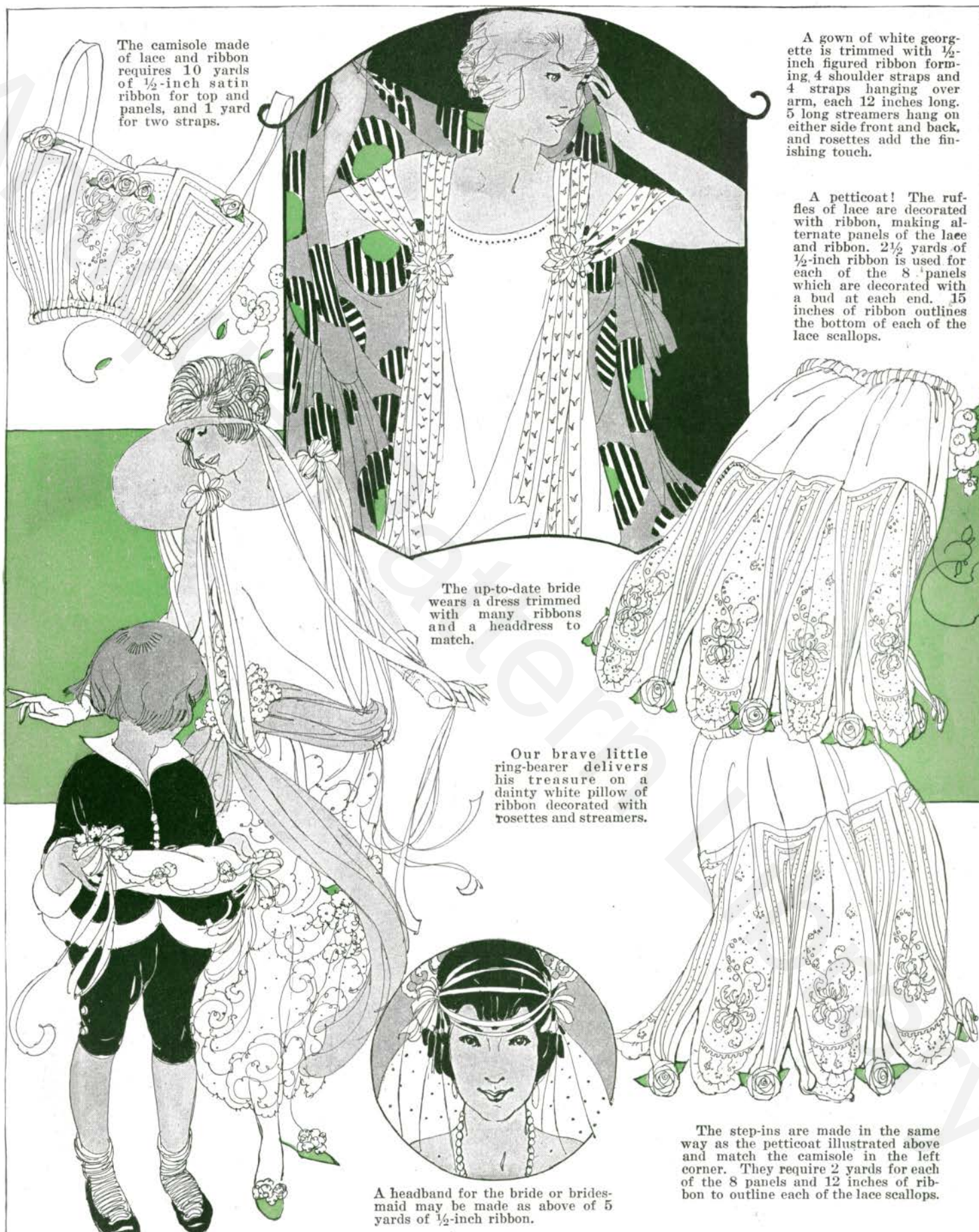

The camisole made of lace and ribbon requires 10 yards of  $\frac{1}{2}$ -inch satin ribbon for top and panels, and 1 yard for two straps.

A gown of white georgette is trimmed with  $\frac{1}{2}$ -inch figured ribbon forming 4 shoulder straps and 4 straps hanging over arm, each 12 inches long. 5 long streamers hang on either side front and back, and rosettes add the finishing touch.

A petticoat! The ruffles of lace are decorated with ribbon, making alternate panels of the lace and ribbon.  $2\frac{1}{2}$  yards of  $\frac{1}{2}$ -inch ribbon is used for each of the 8 panels which are decorated with a bud at each end. 15 inches of ribbon outlines the bottom of each of the lace scallops.

The up-to-date bride wears a dress trimmed with many ribbons and a headress to match.

Our brave little ring-bearer delivers his treasure on a dainty white pillow of ribbon decorated with rosettes and streamers.



A headband for the bride or bridesmaid may be made as above of 5 yards of  $\frac{1}{2}$ -inch ribbon.

The step-ins are made in the same way as the petticoat illustrated above and match the camisole in the left corner. They require 12 yards for each of the 8 panels and 12 inches of ribbon to outline each of the lace scallops.

TO COMPLETE THE COSTUME



$2\frac{1}{8}$  yards of 10-inch ribbon is required for the fashionable girdle above. Both sides have the streamers. The belt is shirred to 3 inches on either side, and beaded ornaments 3 inches wide are placed above the streamers.



The wheel fancy above is only one of the many stunning decorations that are used for sashes and belts. It is made on a cardboard foundation with 4 yards of ribbon for the center and edge. A piece of ribbon is puffed for the center, around which 18 loops, each 1 inch long, are placed. The bias ends on the outside row are each  $1\frac{1}{4}$  inches long.

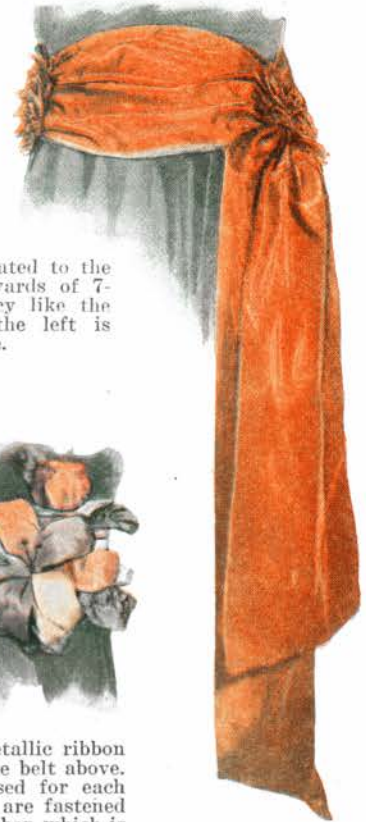

A girdle as illustrated to the right requires  $2\frac{3}{4}$  yards of 7-inch ribbon. A fancy like the one illustrated to the left is placed on either side.



Five strips of metallic ribbon are used to make the belt above.  $\frac{3}{4}$  to 1 yard is used for each strip, and the ends are fastened on a strip of the ribbon which is decorated with 2 small tailor-made bows. A corsage of a lily and a bud decorates the side. (Lily petals made like Jonquil, page 38.)



Black velvet makes a girdle that may be worn with any costume.  $4\frac{1}{8}$  yards of 2-inch ribbon is used for the one illustrated to the left.  $1\frac{3}{4}$  yards is used for the streamers. The twisted rosettes at either side of waistline are made of  $\frac{1}{2}$ -inch velvet, each loop requiring 7 inches of the ribbon. There are 21 petals in each of the rosettes.



The artistic girdle to the left is made of  $\frac{1}{4}$ -inch grosgrain ribbon pulled through wooden beads. Many streamers hang down the sides. For details of working, see page 37.



This girdle shown to the right is made of  $2\frac{3}{4}$  yards of 6-inch ribbon. The streamers are arranged in 3 plaits at top, and the belt is also plaited to a 4-inch width.  $8\frac{1}{2}$  yards of  $\frac{3}{4}$ -inch ribbon is required for the loops which are made on a cardboard foundation. (See diagrams to the left.)

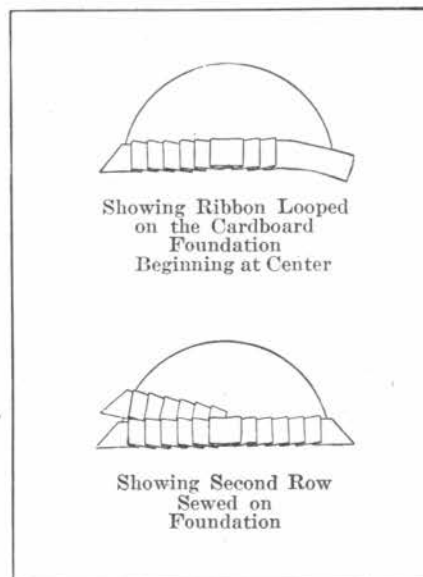

See pages 15 and 16 for Bows, 33 to 39 for Trimmings.

## THAT NECESSARY SPOT OF COLOR



The girdle to the left is made of 5 yards of 1-inch picot-edge ribbon. Allow for waistline. Use  $\frac{3}{4}$  yard for loops on either side and rest for 2 streamers. Belt line is trimmed with buds of  $2\frac{1}{2}$  inches each of 2 contrasting shades of ribbon. See diagram, page 48.



The full-blown rose to the right is one of the simplest flowers in Ribbonland. Each petal takes  $2\frac{1}{2}$  inches of  $1\frac{1}{2}$ -inch ribbon and is shirred at the bottom, and rounded at upper ends. (See page 38.)

Below is an illustration of the fancy used on the girdle to the right. 4 wheels of box plaiting are placed around a foundation of the same ribbon. Steel beads decorate the center.

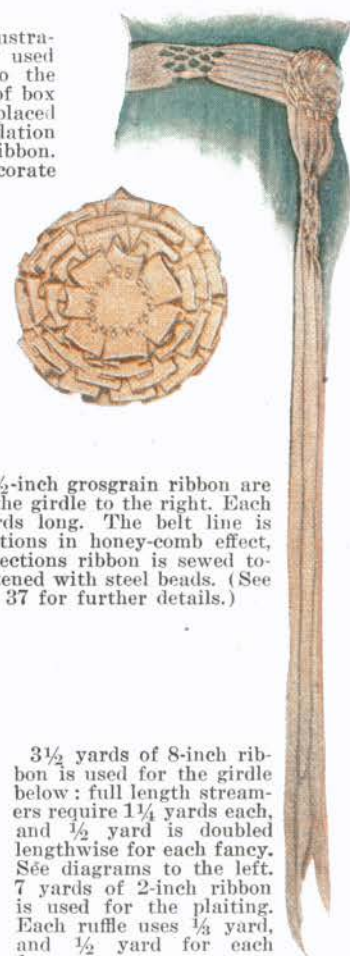

7 strips of  $\frac{1}{2}$ -inch grosgrain ribbon are used to make the girdle to the right. Each strip is 2 yards long. The belt line is knotted in sections in honey-comb effect, and in other sections ribbon is sewed together and fastened with steel beads. (See fringe on page 37 for further details.)

The girdle to the left gives the correct lines and smartness to the most simple garment. Black ribbon with white edge,  $1\frac{1}{2}$  inches wide, is used for waistline made entirely of petals. (See diagrams below.) The large fancy is also made of the petals.



$3\frac{1}{2}$  yards of 8-inch ribbon is used for the girdle below: full length streamers require  $1\frac{1}{4}$  yards each, and  $\frac{1}{2}$  yard is doubled lengthwise for each fancy. See diagrams to the left. 7 yards of 2-inch ribbon is used for the plaiting. Each ruffle uses  $\frac{1}{4}$  yard, and  $\frac{1}{2}$  yard for each fancy.



Ribbon stitched lengthwise as above and shirred to form outside ruffle (to the left).



Ribbon cut for petal.



Plait ribbon, stitching one side as above, and draw thread to form small circle, which is placed in center of the larger circle.



Petal folded and stitched together, along cut edges.

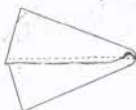

Finished petal.

(Petals that form girdle are shorter than those used in fancy.)

Silver metallic ribbon makes a girdle that is smart. 3 yards of 11-inch ribbon is used for the one to the left. Two buckles are placed at the fastening.



A ribbon belt which is braided in 2 shades of ribbon is the height of good style. Make size required for waistline allowing  $\frac{1}{2}$  yard for braiding. Simple metallic buckles are placed in front for fastening.





## PRACTICAL BAGS MAY BE PICTURESQUE



The bag above for soiled handkerchiefs is gathered on a hoop of 5-inch diameter. 4 pieces of 7-inch ribbon 14 inches long form the bag. 4 pieces of  $\frac{3}{8}$ -inch 2-tone ribbon make the loops at each seam and extend upward to form handle, which is also trimmed at top with simple bow and loops.



The brush bag is made of  $1\frac{1}{8}$  yards of  $5\frac{1}{2}$ -inch ribbon for the foundation, and 2 pockets are placed on the inner side; 1 pocket requires 5 inches of the ribbon and is used for the whiskbroom, and the other 7-inch pocket, for the brush.  $1\frac{3}{4}$  yards of 1-inch velvet ribbon binds the edges and pockets. A loop of velvet is placed at each point and a bow below the large pocket.



The work bag is made of Roman striped ribbon. 2 yards of 7-inch ribbon were used, 1 yard for front and 1 yard for back. The top is 14 inches wide and is attached on a wire foundation. 5 inches of gold metallic ribbon  $1\frac{1}{2}$  inches wide runs down the center, front and back, around which the striped ribbon is shirred. 2 yards of  $1\frac{1}{2}$ -inch gold metallic ribbon binds the top and forms a loop for the handle.



The slipper bag uses 1 yard of  $5\frac{1}{2}$ -inch ribbon for each compartment, allowing  $2\frac{1}{2}$  inches for hem on top. The two inner sides are sewed together, making it necessary to use 1 draw-string of 1-inch velvet, 1 yard long. All the seams are bound with the velvet.



There are many practical uses for such a bag as this one. It is ideal for dainty crocheting and knitting or may be put to good use on shopping days. It is charming, for a straw bag decorated with ribbon drawn through the mesh multiplies its value many fold. The one above has 4 rows of ribbon pulled through. It requires 2 yards of ribbon  $1\frac{1}{4}$  inches wide, and is lined with 2 yards of 7-inch ribbon. Small streamers are placed at each side of the handle.



The above work basket has a wicker bottom and a ribbon top. The diameter is  $5\frac{1}{2}$  inches.  $4\frac{3}{4}$  yards of 5-inch ribbon is used to form top.  $2\frac{3}{4}$  yards 2-tone is used for draw-strings, bows, and for outlining top of wicker basket.



$\frac{3}{4}$  yard of 9-inch ribbon is used for this bag, the same amount for the lining;  $\frac{1}{4}$  yard allowed for pockets.  $6\frac{1}{2}$  yards of 1-inch ribbon are corded and braided for the handle and top. Flower sprays decorate front.

For Bows, Streamers, etc., see pages 15 and 16. For details on Buds, pages 38 and 39.

PARTICULARLY SMART MILLINERY MODES



The hat in the upper corner is trimmed with a large rosette of many loops. 4 rows of loops of varying sizes, all meet in the center.

The hat above requires 2½ yards of 7-inch ribbon. 1¾ yards is used for the loop and end, the remainder around the crown.

The distinctive hat in the center of the page is trimmed with 2¼ yards of 7-inch ribbon; ¾ yard around crown and 1½ yards for loops which are held in place by ribbon wire.

The hat above with streamers requires 6½ yards of ½-inch grosgrain ribbon, 1½ yards for crown and 2½ yards for each of the side decorations.

The hat in the upper right hand corner requires: 2½ yards 6-inch ribbon—1¾ for bow and ¾ for crown. The bow is wired.

Rosettes on hat above require 5 yards of 5-inch ribbon. One is placed below and one above the brim.

Millinery Bows and Fancies are described in detail on pages 15 and 16.

## BRIMFUL OF SMARTNESS ARE THESE RIBBON TRIMMED HATS



*A Hat Favored with a Seven-Looped Bow*

4 yards of 5-inch ribbon is needed for the 7-looped satin bow above. If the crown is decorated, an extra  $\frac{3}{4}$  yard is required.

2 yards of 9-inch ribbon makes the bow for the hat below.



*Distinctive Smartness Is Added by a Looped Bow Tilted at One Side of a Hat*



Each wheel fancy takes 5 yards of 2-inch grosgrain ribbon. (See pp. 33 and 36.)

*Style Takes on a New Angle in the Chic Hat Trimmed with Tailor-made Wheels of Ribbon*



The very fashionable hat below requires for its bow trimming,  $2\frac{1}{2}$  yards of 6-inch ribbon with a fancy edge.



*Such Bows Add Chic and Completeness*

The Youthful hat above uses  $2\frac{1}{4}$  yards of 6-inch ribbon. One loop of  $\frac{1}{2}$  yard is placed on crown and 2 streamers hang down from the brim. The crown requires  $\frac{3}{4}$  yard additional.



*A Band of Ribbon That Binds the Latest Fashions*

A band of oddly twisted ribbon is all that is needed for good taste and good style. 2 yards of 3-inch ribbon is required. (See pages 34 and 35 for ribbon plaiting.)

*How to make Bows, see pages 15 and 16; for other Millinery Trimmings, see pages 33 to 39.*

# KNACKS OF THE PARISIAN MODISTE

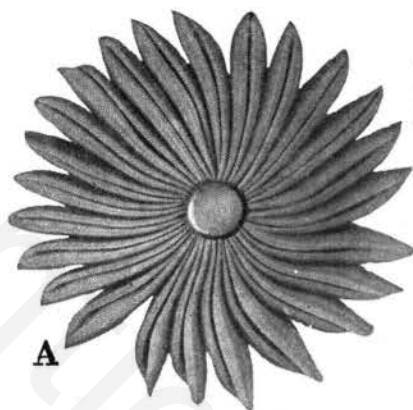

A

C—Details for making this effective cockade are the same as illustrated for A. Turn finished cockade so that the back becomes the front as indicated in Fig. 6. Tack the outer points into a small circle. The inner points are already tacked to form a circle. Draw a ribbon through these two circles, and place a knot over the upper one, as indicated in illustration.

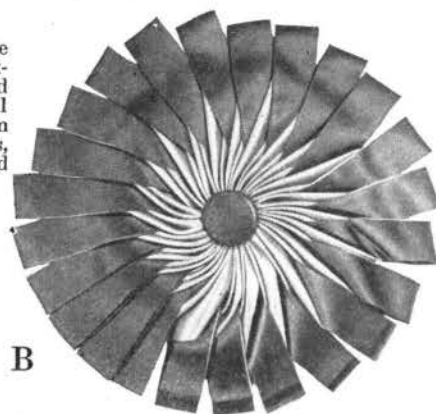

B

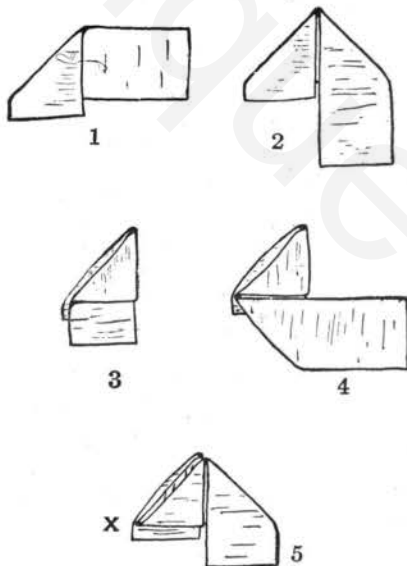

D—Process of making this dainty trimming is exactly the same as that employed in the first five steps of Fig. A. Cockade is turned face backward, as indicated in Fig. 6; the inner and outer points are laid one over the other and tacked together, forming one center circle through which a piece of ribbon is drawn and knotted as illustrated.

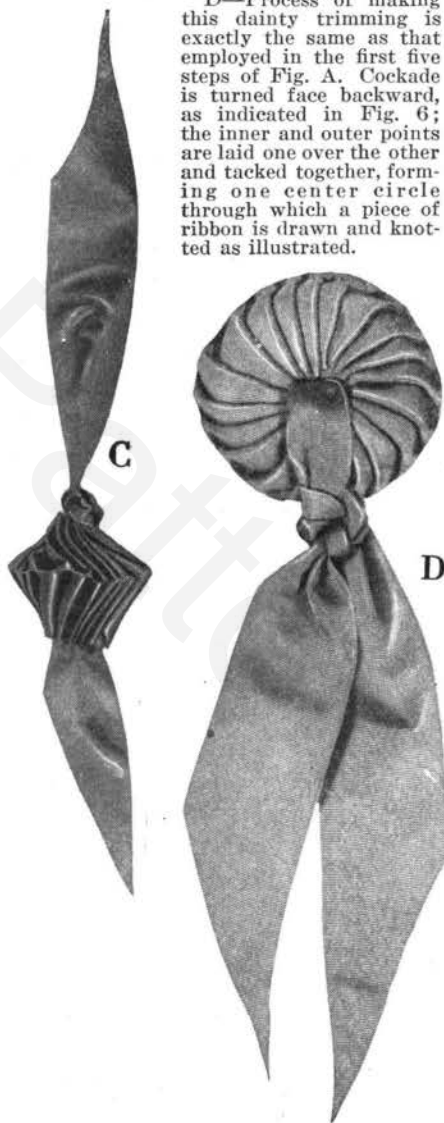

C

A—The rosette at the upper left is as easy to make as it is charming when completed. Take ribbon  $1\frac{1}{2}$  inches wide or wider, preferably grosgrain, and after making bias folds as indicated in Figs. 1 and 2, place the right-hand bias immediately over the left-hand bias as indicated in Fig. 3. This gives the first petal of the cockade. Fold the remaining portion of the ribbon at right angles as indicated in Fig. 4 to form another bias and lay the third bias over the second. Then repeat the first step as indicated in Fig. 5, again laying the right-hand bias over the left-hand bias, which gives two petals. When these two petals are done, start tacking at the inner points where the petals meet, indicated by letter X in Fig. 5, and begin the third petal as indicated in Fig. 4, repeating until 24 petals are done. Finish center, where points are connected, with self-covered button. Of  $1\frac{1}{2}$ -inch ribbon, 2 yards are required for a 24-petal cockade. Of 2-inch ribbon, 4 inches are required for each petal.

D

B—Make center exactly like Fig. A, placing a loop of contrasting ribbon in the slit between each petal.

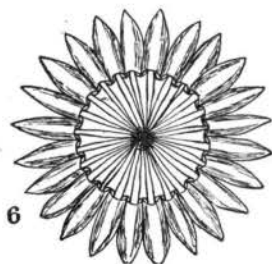

6

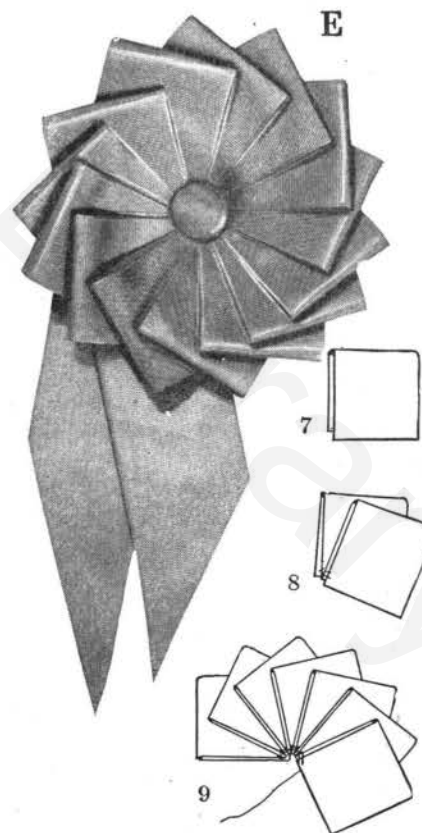

E

E—Any width ribbon may be used to make this ornament, which is particularly desirable for children's hats. Take a length measuring twice the width of the ribbon and fold over as indicated in Fig. 7, each loop being a perfect square. After 14 have been made, and piled one on top of the other as indicated in Fig. 8, draw a needle through the lower left-hand corner of all the squares. Tack securely. Then begin pushing each looped petal out, spacing evenly to form a complete cockade, as in Fig. 9. There are 2 ends on the one illustrated. The center is finished with a self-covered button.

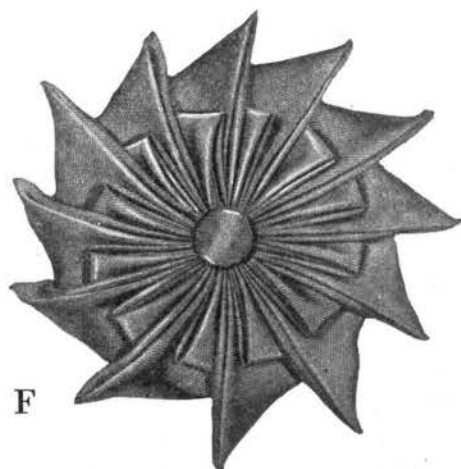

F

F—Is exactly the same as A, excepting that every other petal-point is folded in toward the center and tacked.

# RIBBON SHOWS ITSELF EVERYWHERE

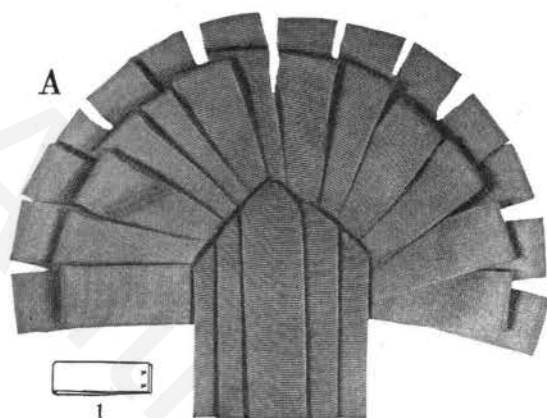

A—32 pieces of ribbon each 4 inches long are required to make this ornament. 14 pieces, folded into 2-inch loops as indicated in Fig. 1, are laid on a foundation to form a semicircle, as indicated in Fig. 2. 13 2-inch loops are also laid in a semicircle  $\frac{1}{2}$  inch below the outer edge of the first row of loops, as indicated in Fig. 3. 5 pieces of ribbon are required to cover the center. The cut ends of the ribbon are folded diagonally, as indicated in Fig. 4, and placed one over the other as illustration shows.

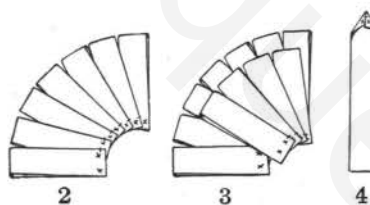

C

C—2 pieces of ribbon the required length are laid vertically side by side. Another ribbon of equal length is drawn over the left-hand piece and under the right-hand piece and under the right-hand piece, forming a lattice.

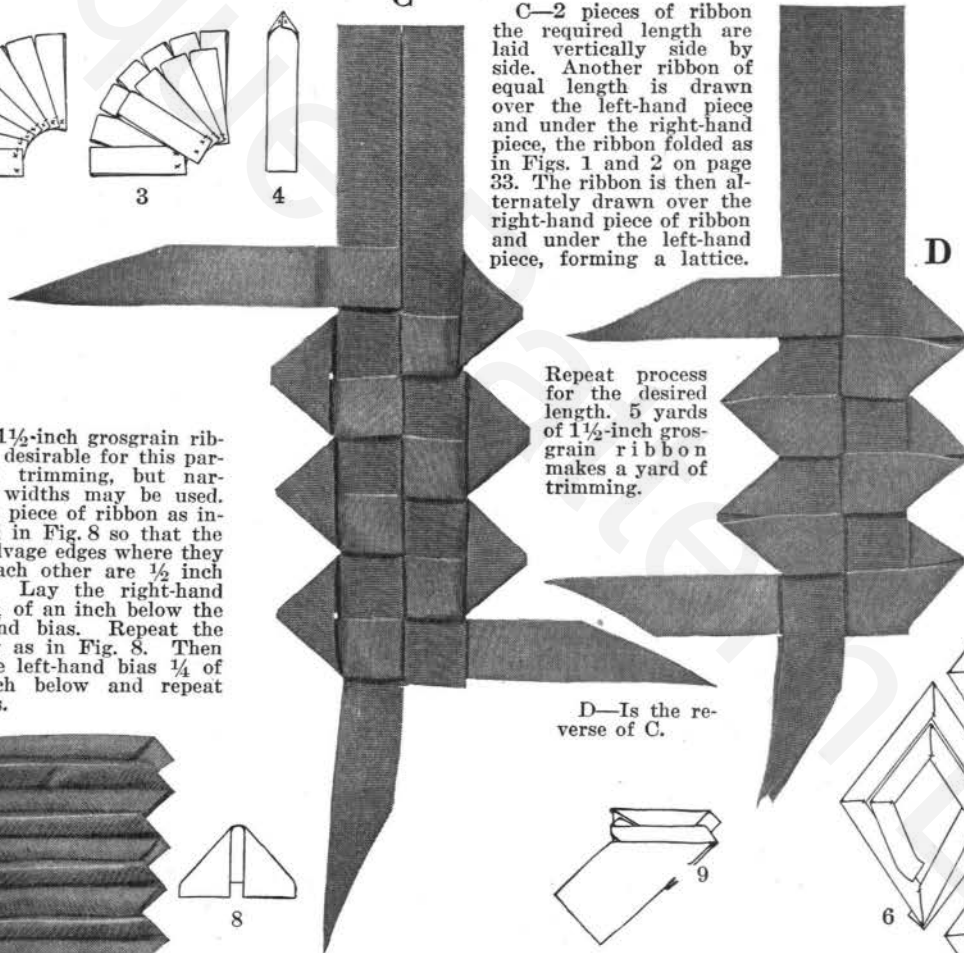

Repeat process for the desired length. 5 yards of  $1\frac{1}{2}$ -inch grosgrain ribbon makes a yard of trimming.

D—Is the reverse of C.

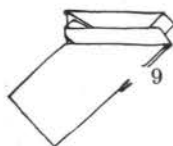

F—Is made in the same manner as E, excepting that a straight edge—often desirable on hats and dresses—is obtained by tucking in the points on the left side—or the right if desired—as illustrated in Fig. 9.

G—Is the reverse side of E. It can be pulled out and twisted about to form a variety of very interesting cockades, finished in the center with self-color or contrasting buttons or streamers, as desired.

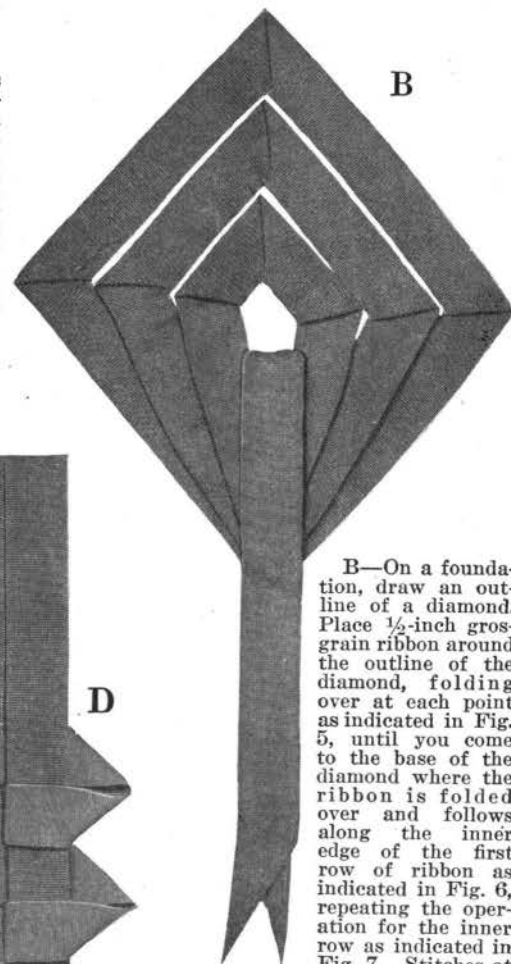

B—On a foundation, draw an outline of a diamond. Place  $\frac{1}{2}$ -inch grosgrain ribbon around the outline of the diamond, folding over at each point as indicated in Fig. 5, until you come to the base of the diamond where the ribbon is folded over and follows along the inner edge of the first row of ribbon as indicated in Fig. 6, repeating the operation for the inner row as indicated in Fig. 7. Stitches at the base of the diamond are covered by a piece of ribbon 12 inches long which makes the two ends.

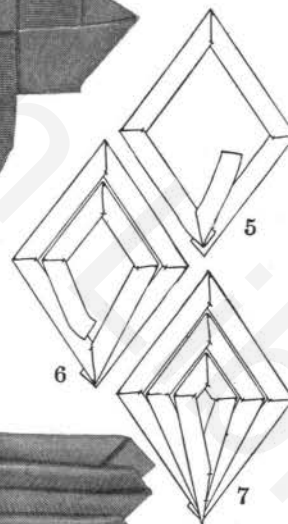

E— $1\frac{1}{2}$ -inch grosgrain ribbon is desirable for this particular trimming, but narrower widths may be used. Fold a piece of ribbon as indicated in Fig. 8 so that the two selvage edges where they face each other are  $\frac{1}{2}$  inch apart. Lay the right-hand bias  $\frac{1}{4}$  of an inch below the left-hand bias. Repeat the folding as in Fig. 8. Then lay the left-hand bias  $\frac{1}{4}$  of an inch below and repeat process.

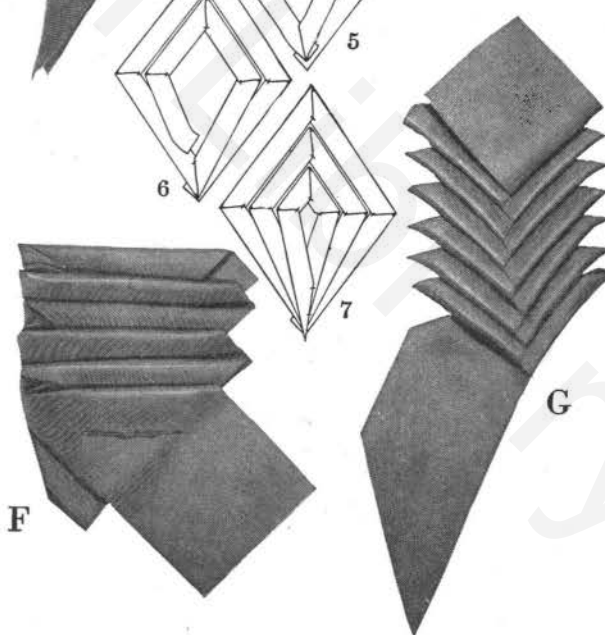
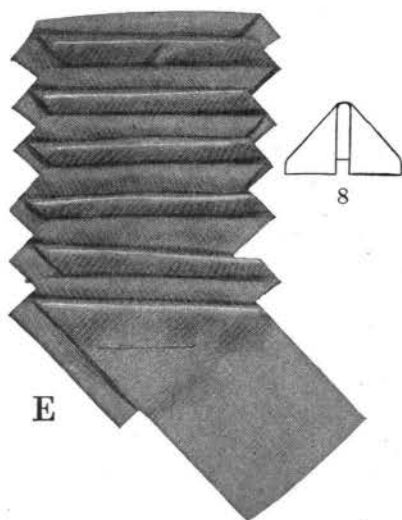

TRIMMINGS THAT LEND THEMSELVES TO MANY DECORATIONS

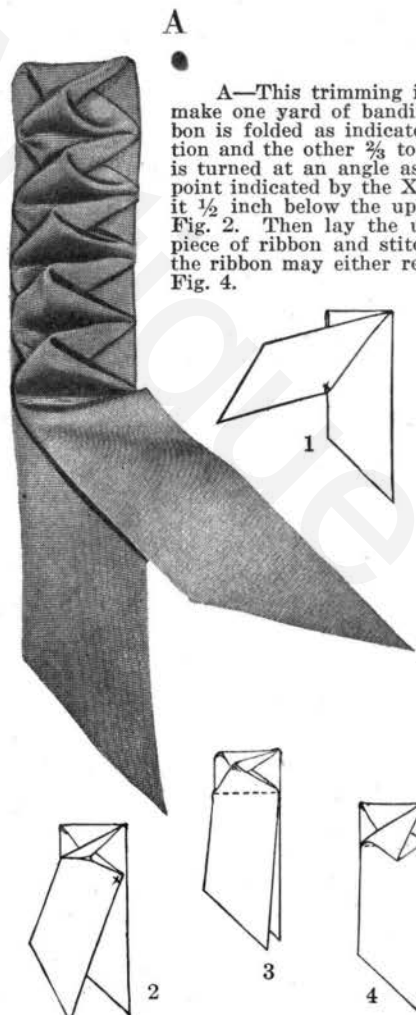

**A**—This trimming is effective for hats and dresses. In order to make one yard of banding, 3 yards of ribbon are required. The ribbon is folded as indicated in Fig. 1,  $\frac{1}{3}$  being required for a foundation and the other  $\frac{2}{3}$  to make the puffing. The upper piece of ribbon is turned at an angle as indicated in Fig. 1. Take the ribbon at the point indicated by the X, bring it over to the right-hand side and tack it  $\frac{1}{2}$  inch below the upper fold on the right selvage, as indicated in Fig. 2. Then lay the upper piece of ribbon directly over the lower piece of ribbon and stitch across as indicated in Fig. 3. The puff of the ribbon may either remain turned up, as in Fig. 3, or down, as in Fig. 4.

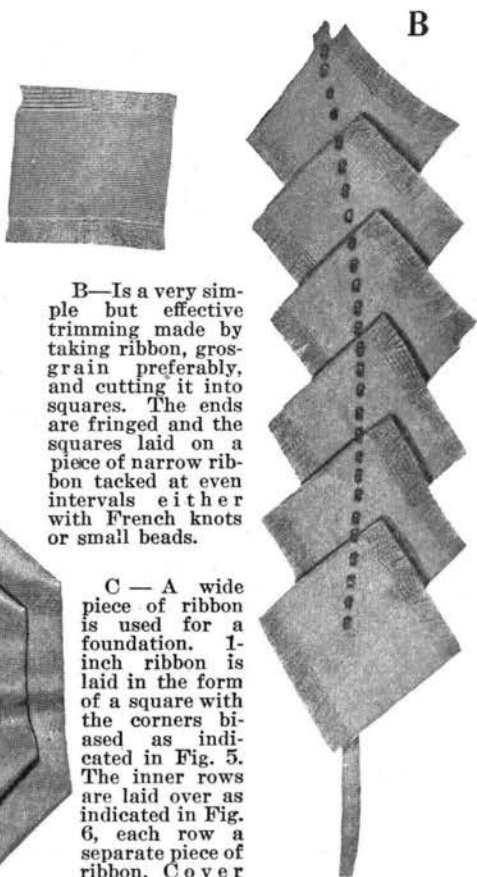

**B**—Is a very simple but effective trimming made by taking ribbon, gros-grain preferably, and cutting it into squares. The ends are fringed and the squares laid on a piece of narrow ribbon tacked at even intervals either with French knots or small beads.

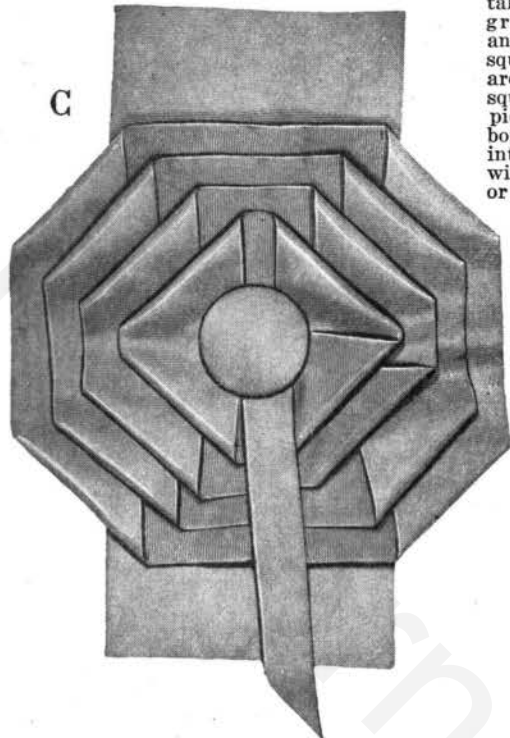

**C**—A wide piece of ribbon is used for a foundation. 1-inch ribbon is laid in the form of a square with the corners biased as indicated in Fig. 5. The inner rows are laid over as indicated in Fig. 6, each row a separate piece of ribbon. Cover stitches with button and two ends, as illustrated.

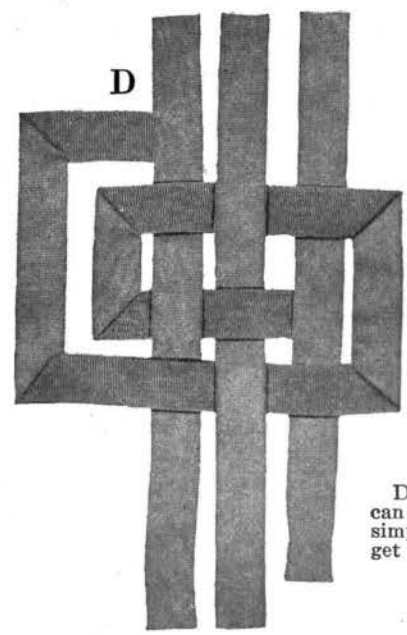

**D**—Infinite variety of Roman key patterns can be made of ribbon. The one illustrated is simple to follow. Care must be exercised to get the corners turned at definite right angles.

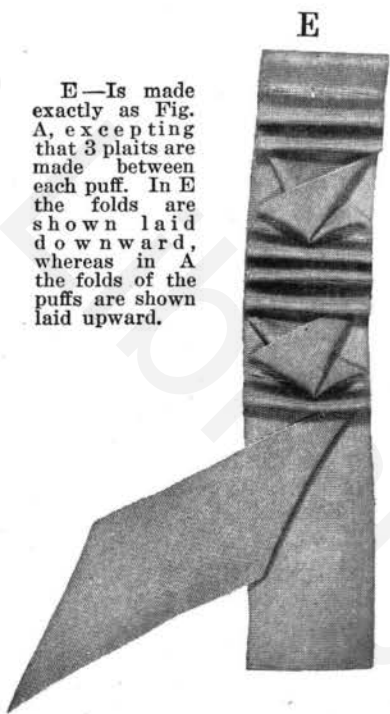
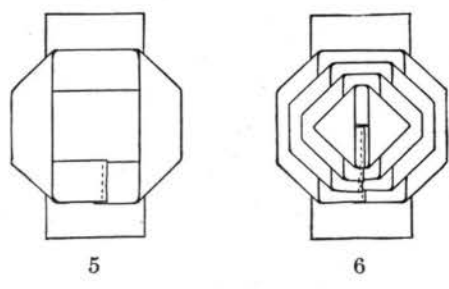

**E**—Is made exactly as Fig. A, excepting that 3 plaits are made between each puff. In E the folds are shown laid downward, whereas in A the folds of the puffs are shown laid upward.

# EFFECTIVE DRESS AND MILLINERY TRIMMINGS

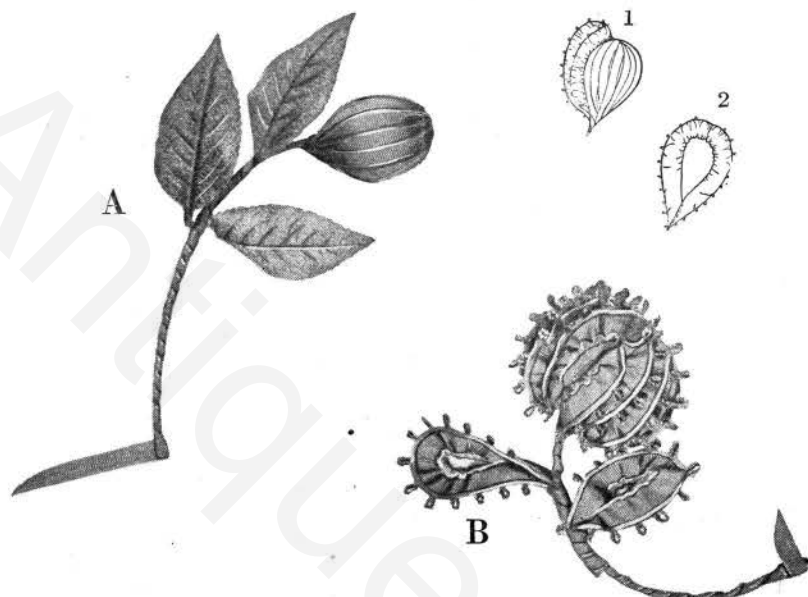

A—Insert a piece of wire through the center of a mold made of wood, tissue paper, or cotton. Cover the entire mold with milliner's glue and wind  $\frac{1}{4}$  inch grosgrain ribbon over it as indicated in illustration. Continue winding about 1 inch down the stem and then insert the leaf. Repeat the winding and insert the other leaves at intervals desired, until entire stem is covered.

B—Is made exactly as A, excepting that a picot-edge ribbon is slightly gathered as indicated in Fig. 1, and tacked in vertical rows on the ribbon-covered mold, making a chestnut burr in effect. The leaves are made by drawing up the thread on the inner picot selvage and looping the ribbon as indicated in Fig. 2. These leaves are caught in the stem in the same manner as in illustration A.

C—Is made on the same kind of mold as A and B, excepting that the gathered picot-edge ribbon is tacked spirally over the entire mold and two ends of the same ribbon are suspended from the base of it. The irregular effect is caused by the gathers. The two ends are tacked at the base.

D—A piece of cardboard or buckram 1 inch wide by 7 inches long is tacked with an inch overlapping, making a circle 6 inches in circumference. This is covered inside and out with 6 inches of grosgrain ribbon. 12 pieces of ribbon 10 inches long, 1 inch wide, are required for the knotted ends. These are knotted 3 inches from each end and are folded in the center. These folded pieces are tacked top and bottom as illustrated in Fig. 3, at intervals of  $\frac{1}{2}$  inch apart around this frame. An additional piece of ribbon is looped between each one of the tackings in the same manner as one would make a buttonhole stitch, as indicated in Fig. 4. The ribbon is then spread so that the knots make a regular circle. The ends are cut diagonally.

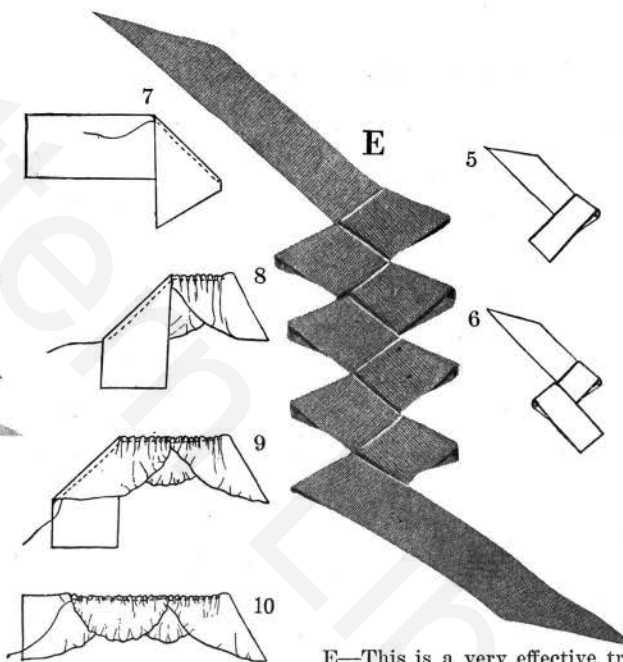
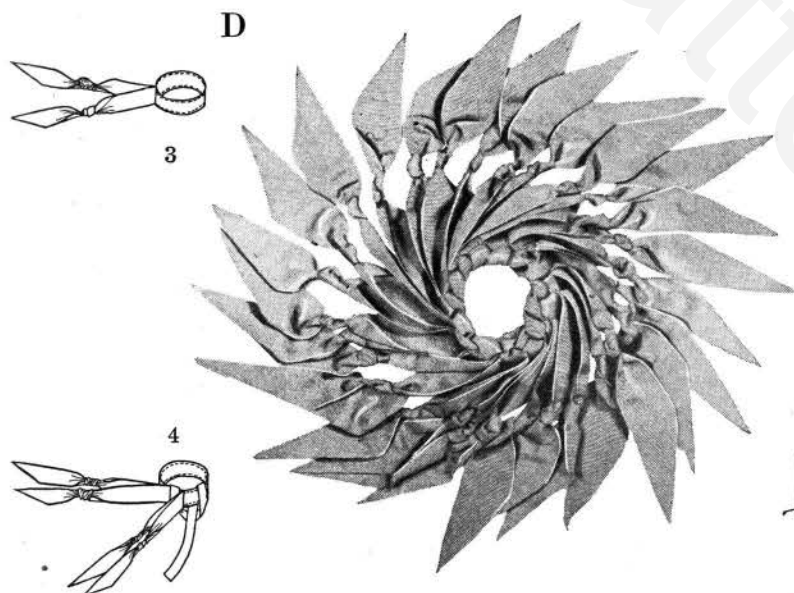

E—This is a very effective trimming for a dress or hat. Fold a piece of ribbon as indicated in Fig. 5, and tack. Then reverse the loop as indicated in Fig. 6, tack again, forming a double diamond shape. The process is repeated as many times as required for the length of trimming needed. Several widths of ribbon are suitable, but the  $\frac{1}{2}$ -inch width in grosgrain is preferable.

F—Fold a piece of ribbon as indicated in Figs. 1 and 2 on page 33. Gather the ribbon one-sixteenth of an inch from the edge on the bias, fold as indicated in Fig. 7 to the right. Refold the balance of the ribbon in the same manner, continuing to gather the other crease as in Figs. 8 and 9. The size of the loops can be regulated by the fullness of the shirring as indicated in Fig. 10.



# MODISH TRIMMINGS FOR THE FROCK OR BONNET

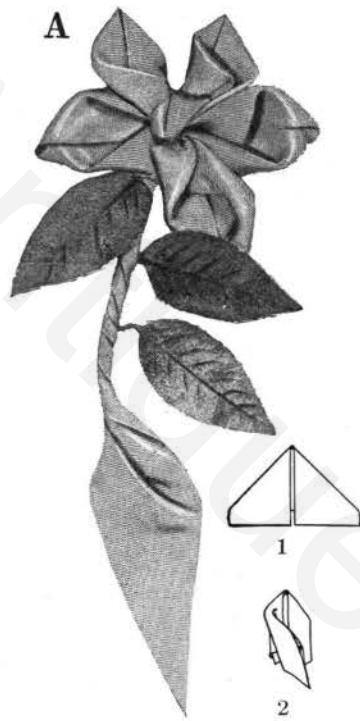

A—Grosgrain ribbon from 1 to 2 inches wide may be used for this effective flower. The ribbon is folded for each petal as indicated in Fig. 1. The outer points are folded over as indicated in Fig. 2. Repeat this process until the desired number of petals are made. The ribbon should be cut for each petal. Attach a wire for the stem to the connecting point of all the petals. Cover with a knot and continue to wind the ribbon about the stem, adding leaves at desired intervals.



B—Fringe made of ribbon is particularly desirable to finish sash ends. Any even number of strands may be employed. The top of the fringe should be tacked to a piece of cardboard as indicated in Fig. 3 above. The first and second strands are knotted together, the third and fourth are knotted, and so on across the entire number of strands. (See Fig. 4.) About  $\frac{1}{4}$  inch below the first row of knots, the second and third strands should be knotted, then the fourth and fifth, and so on, repeating the knotting in the same manner until the desired number of rows are finished. (See Fig. 5.) Wider ribbon may be utilized, but  $\frac{1}{4}$  inch is preferable.

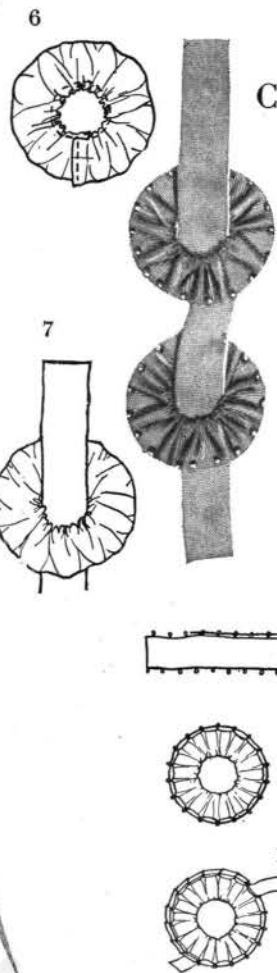
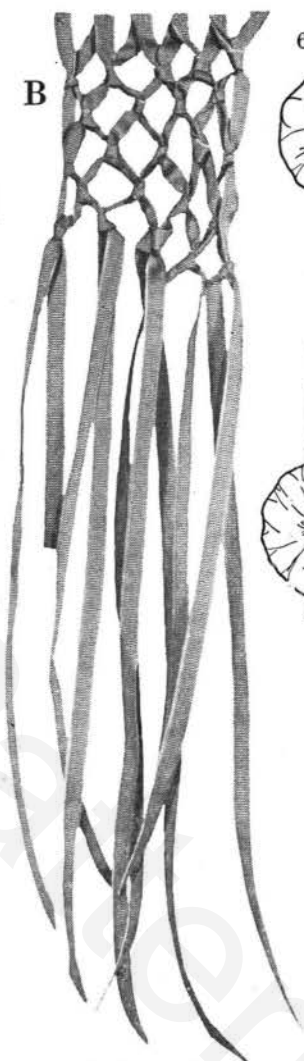

C—A very smart yet simple trimming is made by gathering 3 inches of  $\frac{3}{8}$ -inch ribbon to form a circle  $\frac{3}{8}$  inch in diameter as indicated in Fig. 6 to the left. A ribbon is drawn through the rings over the seams as in Fig. 7. In tacking this ribbon on to the material which it will trim, steel beads may be used along the outer edges.

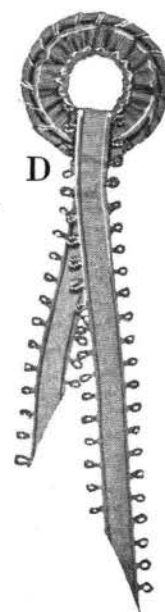

D—A wire is drawn through each of the loops of a loop-edged ribbon as illustrated in Fig. 8. Form a complete circle as illustrated in Fig. 9. The thread making the loop-edge on the inner part of the circle is drawn in, forming the gathers and the inner circle. Narrow baby ribbon is used to cover the wire between each loop as illustrated in Fig. 10. In order to cover the seam a length of ribbon is drawn through the hole, making streamers.

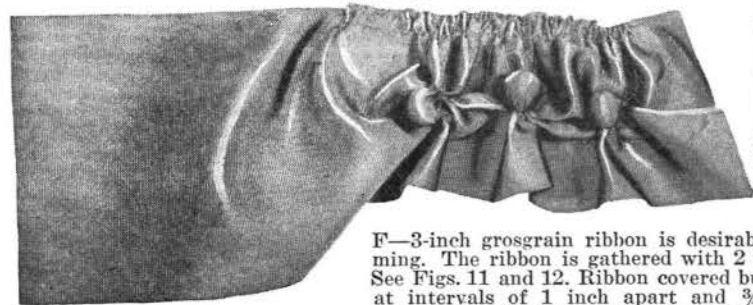
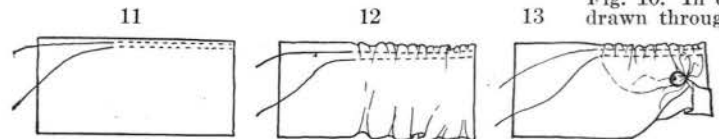

F—3-inch grosgrain ribbon is desirable for this trimming. The ribbon is gathered with 2 rows of shirring. See Figs. 11 and 12. Ribbon covered buttons are placed at intervals of 1 inch apart and  $\frac{3}{4}$  inch from the lower edge. See Fig. 13. This ruffle can be converted into a very interesting band if gathered at the lower selvage as well.

E—A piece of light ribbon and a piece of dark ribbon are placed at angles indicated in Fig. 14. Fold the dark ribbon over the light ribbon as indicated in Fig. 15 and then fold the light ribbon over the dark ribbon in the same manner, repeating the process until sufficient of this effective trimming is obtained. Tack at frequent intervals.

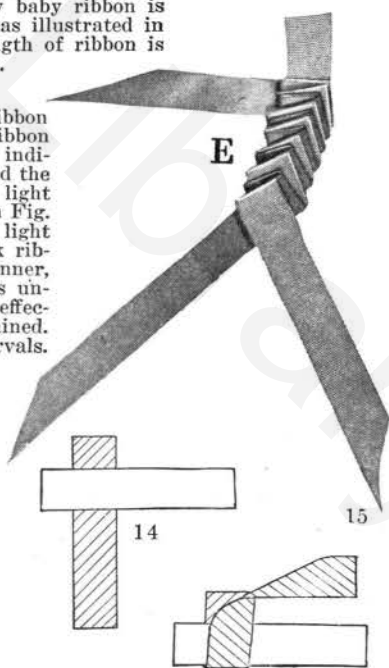



# WHEN RIBBON BLOSSOMS INTO FLOWER

*Full Blown Rose*

When this blossom is made of varying shades of pink and rose, or the lighter orange yellow tones, the creation rivals Nature's fairest flower. The center petals which gather around stamens of yellow, are small, each succeeding row of petals increasing in size. Petals, varying slightly in shape from Fig. 1, are cut from a 3 or 5 inch satin ribbon. The outer edge of each petal, on the back, is tipped with milliner's glue; the edge is then turned back one-sixteenth of an inch and pressed with a warm iron. (See Fig. 2.) The smaller petals are gathered around the stamens, and the next larger size petals, laid around petal by petal until the flower is completed. A stem with leaves attached is fastened to the center of the flower after all the petals have been assembled, and a calyx attached where the stem connects with the blossom. (A calyx may be purchased in a millinery supply dept.)

3  
These are back views of petal.

4

When one has learned to make this simple rose petal, roses may be made in an endless variety. A piece of ribbon is folded in half and gathered at the bottom. The corner of each loop is turned back as in Figs. 3 and 4. The first petal is rolled spirally as in Fig. 6 below and each successive petal partially surrounds the preceding petal, until a bud or full rose is formed. Stem and calyx are added.

5 6 7

The details of both these buds are the same excepting that the first one is made of a ribbon with a heavy satin edge, and in the second one, the ribbon is folded double. The ribbon is first twisted spirally as in Figs. 5 and 6 and continues to wind spirally. When a bud or rose of the size desired is obtained, the ribbon is pulled down toward the stem, as in Fig. 7, and is tied with thread, connected to the stem, and finished with a calyx.

8

Four petals, similar in shape to Fig. 8, are cut out of a piece of satin ribbon. The edges are tipped with milliner's glue, turned back one-sixteenth of an inch, and pressed with a hot iron. The petals are then gathered about a few stamens, fastened to a wire stem, which is covered with dark green ribbon.

9 10

This is the front view of the attractive jonquil illustrated in color on the back cover. The center of the jonquil is made like the poppy bud, Fig. C, page 39, and the outer petals as indicated in Fig. 10. A piece of ribbon is folded over (see Fig. 9) and a short piece of fine wire runs down the center, held down by the stitches which connect the ribbon forming the petal. Five petals surround the center. These are bent back to simulate the petals of a jonquil.

GAY TOUCHES FROM THE GARDEN OF RIBBONS



Sweet Peas

The inner and outer petals are made in the same manner, except that a 1½-inch ribbon is used for the outer petal, and this ribbon cut through the center (half width) is required for the smaller petal. Cut ribbon as in Fig. 1, gather and fold over as in Fig. 2, winding a wire around the blossom. The bottom of the flower is finished with a calyx.

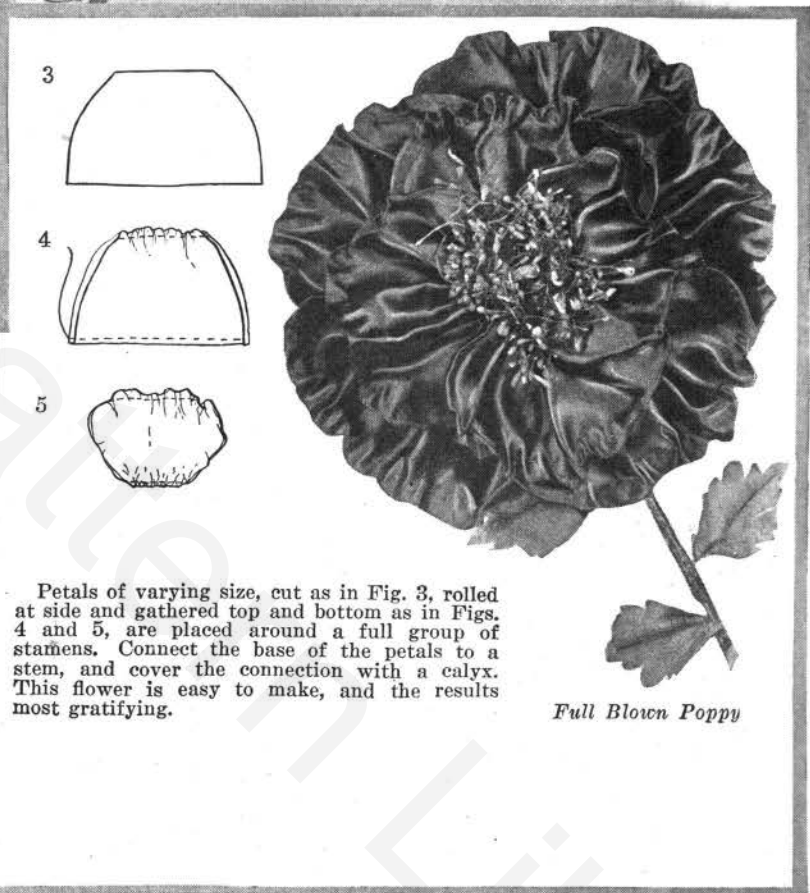

Full Blown Poppy

Petals of varying size, cut as in Fig. 3, rolled at side and gathered top and bottom as in Figs. 4 and 5, are placed around a full group of stamens. Connect the base of the petals to a stem, and cover the connection with a calyx. This flower is easy to make, and the results most gratifying.

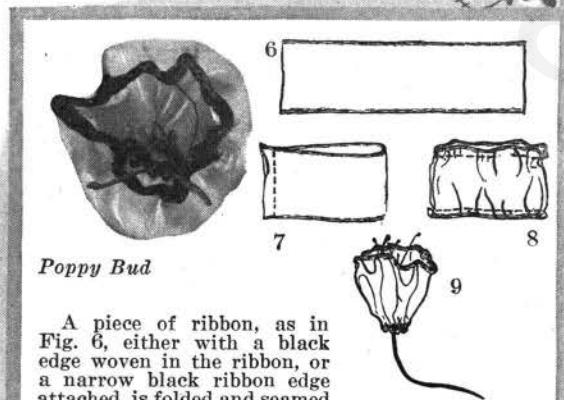

Poppy Bud

A piece of ribbon, as in Fig. 6, either with a black edge woven in the ribbon, or a narrow black ribbon edge attached, is folded and seamed as in Fig. 7. This loop of ribbon is turned inside out, to hide the seam. It is then gathered top and bottom as in Fig. 8 and the lower gather pulled in tightly around a stem to which the stamens have been attached. A dozen of these flowers makes an effective corsage.

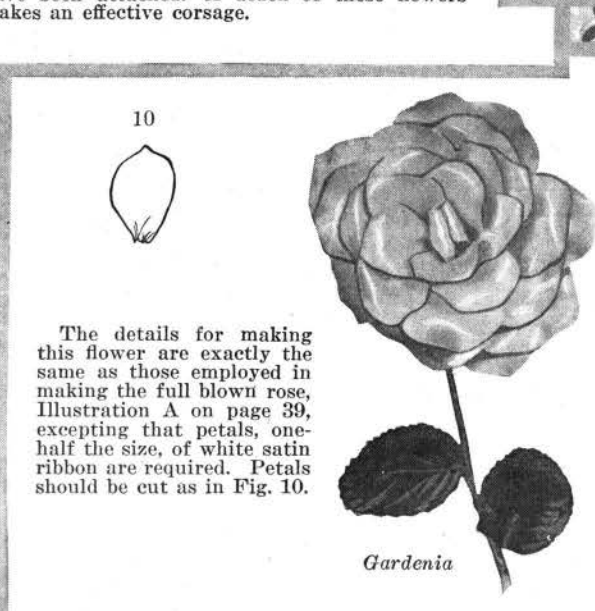

Gardenia

The details for making this flower are exactly the same as those employed in making the full blown rose, Illustration A on page 39, excepting that petals, one-half the size, of white satin ribbon are required. Petals should be cut as in Fig. 10.



Rosebuds

A single piece (not doubled) of 2-toned ribbon is cut as in Fig. 11, the upper corners being rolled back and tacked, showing the 2 shades of ribbon. Gather at the base, as Fig. 12. The inner petals require ¼ to ½ inch less ribbon than the outer petals, and are rolled tightly for first petal, as indicated on bud in illustration. The other petals are laid around the inner petal until a blossom of the size desired is completed.

# Simple Ways of Making Many Things Decorations of Decorations Used on Other Pages

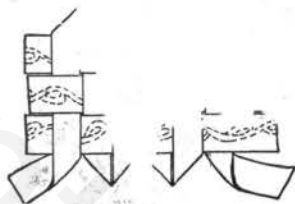

Lattice Work of Ribbon and Lace. Pointed Ends of Ribbon

Many articles of decoration or wearing apparel need only the above variation for trimming. The lace runs crosswise and the ribbon up and down, overlapping to form a point.



Strips of Ribbon Knotted in Center



Knotted Loop

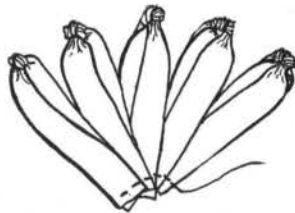

Many Loops to Form Rosette

Rosette Knotted at Top of Each Loop

A rosette made like the one above is used as a fancy touch for dresses, hats and underthings. Simple to make.

Shirring and Plaiting

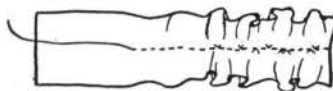

Diagram 1. Ribbon Shirred through Center. Requires 1½ times as much material as covered space.



Diagram 2. Ribbon Ruffled at One Selvage. Twice amount of Ribbon as covered space.

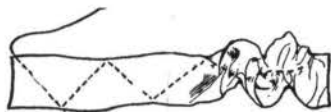

Diagram 3. Triangle to Give Pointed Effect. Twice as much material as space to be covered.

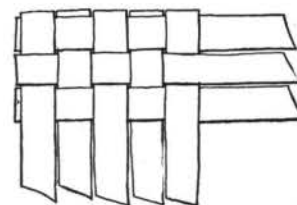

Diagram 4. Ribbon side plaited for ruffle. Use twice as much material as space covered.



Diagram 5. Ribbon plaited in honey-comb effect. Use twice as much ribbon as space to be covered. Very effective trimming.

Rosettes or Single Bows Easily Made



Lattice Work of Ribbon. Ribbon Running Lengthwise and Crosswise

This is a simple form of decoration and is worked in the same manner as the lattice to the left. The crown of a hat, pillow, etc., may be decorated in this charming fashion.

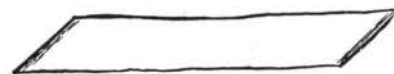

Strip of Ribbon Cut on the Bias



Ribbon Folded Lengthwise



Forming Bud



Finished Bud

Simple Bud Made of One Strip of Ribbon

A bud like the above is one of the simplest decorations, and many of them can be made in a short time, and at little cost.

Turned Petal

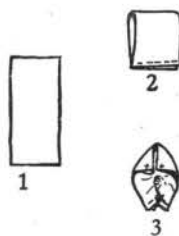

Make petal above by folding strip of ribbon as in 2. Lap over both upper corners and gather at bottom as in 3. Many of these petals placed around some stamens (bought in millinery supply departments) will make charming trimmings.

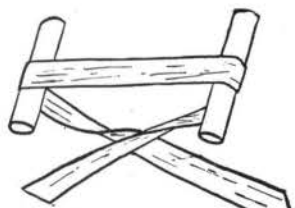

Twist on Fingers or Parallel Bars

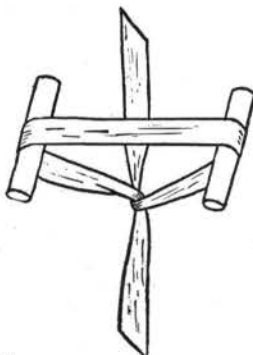

Single Bow in Process of Knotting



Single Bow as in Process 2

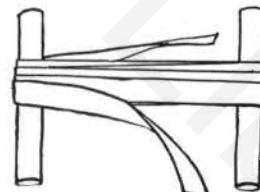

Twist Ribbon Around Many Times for Rosette

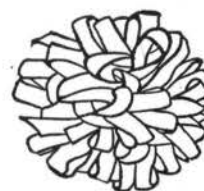

Rosette Made as in Process 3

Simple Petal



Make rows of stitching around the 3 sides as in the picot-edged ribbon in 1. Pull thread forming the shirred petal as in 2. Many of the most effective flowers are made in this simple way.

SOFT GLOWS THE LIGHT THROUGH RIBBONS SIFTED



The exquisite lampshade above, built like a drum, is made of strips of ribbon laid vertically in the upper section and horizontally in the lower section. The thickness of 3 inches is also made in horizontal strips. Gold lace decorates both sides of the shade and large gold tassels and fringe are placed at the front.  $\frac{3}{4}$ -inch ribbon is used throughout. A flower spray made of ribbon is placed on the top of the fringe.

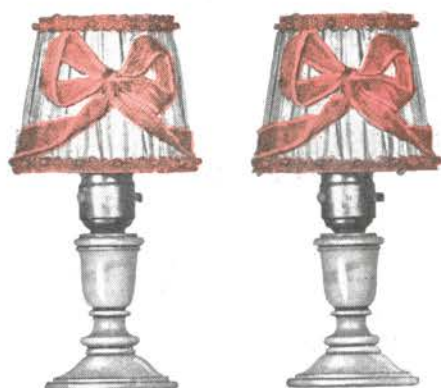

The pair of lampshades above have a diameter of 4 inches at the bottom of the shade.  $\frac{3}{4}$  yard of  $3\frac{1}{2}$ -inch ribbon covers the shade. Two-thirds yard of  $\frac{1}{4}$ -inch gold lace is placed around top and bottom, and  $\frac{3}{4}$  yard of  $\frac{1}{2}$ -inch ribbon is used for the bow.

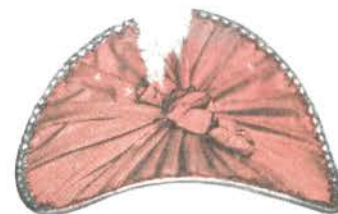
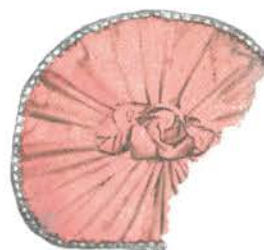

The concave shields above require for each of them:  $1\frac{1}{2}$  yards of  $3\frac{1}{2}$ -inch ribbon shirred to a point in the center and decorated with buds and leaves. Two-thirds yard of  $\frac{1}{4}$ -inch gold lace is placed around the circumference. 8 inches of ribbon 5 inches wide used for the lining.



A hanging shade like the one above is easily made; it is 5 inches in diameter and 7 inches high and has 4 panels. Each panel requires 7 inches of  $4\frac{1}{2}$ -inch ribbon. The seams, top and bottom, are decorated with 4 yards of ribbon shirred through the center (see diagram 1, page 40). Another  $1\frac{1}{2}$  yards are allowed for the top streamers and bow.

This effective floor lamp is lined with a 12-inch printed ribbon, the pattern of which reflects itself through the chiffon which covers it. Gold lace adds a note of richness and beauty to the ensemble. The ruffle around the bottom is made of chiffon and is covered with lace. The lace at the top, the panel in the center, and the ruffle are trimmed with bowknots of ribbon with a rosebud in the center.

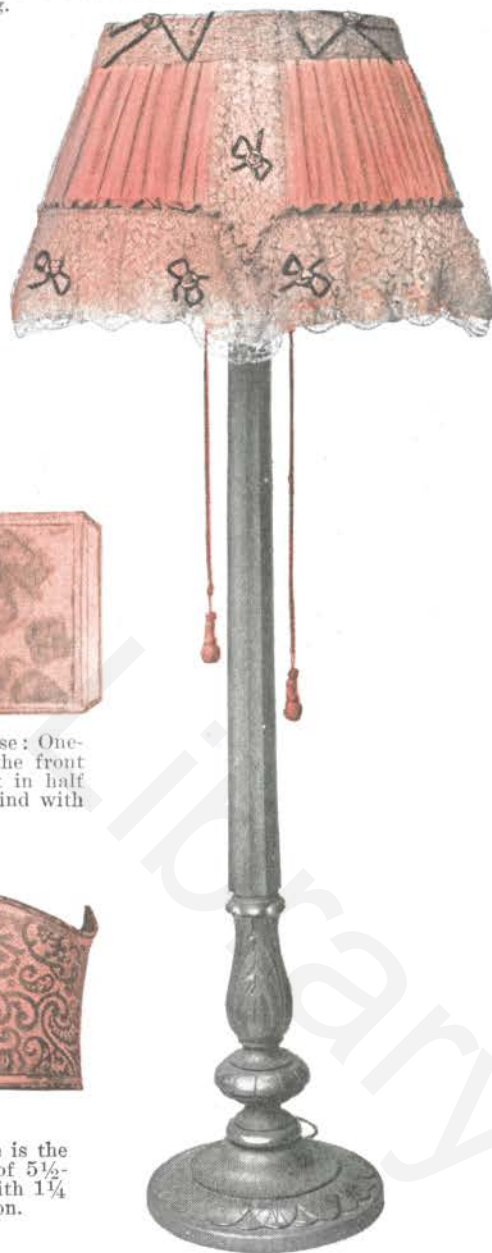

For each of the shields above use: One-sixth yard of 5-inch ribbon for the front panel, and the same amount cut in half for each of the 2 side panels. Bind with  $1\frac{1}{8}$  yards of  $\frac{1}{2}$ -inch ribbon.



A shield to fit the double fixture is the one above. Cover with  $\frac{1}{2}$  yard of  $5\frac{1}{2}$ -inch ribbon and outline all sides with  $1\frac{1}{4}$  yards of 1-inch gold metallic ribbon.

For detailed descriptions of Bows, see pages 15 and 16; Buds and Flowers, pages 38 and 39.

## BAGS AND PURSES—PROUD WITH RIBBON



The bag is 10 inches long by 8 inches wide. It requires  $2\frac{1}{2}$  yards of  $1\frac{1}{2}$ -inch ribbon and  $4\frac{1}{2}$  yards of  $\frac{1}{2}$ -inch forming double rows. 20 inches of  $1\frac{1}{2}$ -inch ribbon for top, allowing  $\frac{1}{4}$ -inch hem for draw-strings. It is lined with four 10-inch strips of ribbon 5 inches wide.



The crocheted ribbon bag above is 10 inches long. The inside is made of two 10-inch lengths of  $4\frac{1}{2}$ -inch ribbon, and outside handle and tassel of baby ribbon.



The convenient bag above is made of 2 lengths of ribbon 8 inches wide by 9 inches long for front and back; plain ribbon is used for the lining and pockets.



An envelope bag entirely made of ribbon and trimmed with bands of a contrasting color is charming.

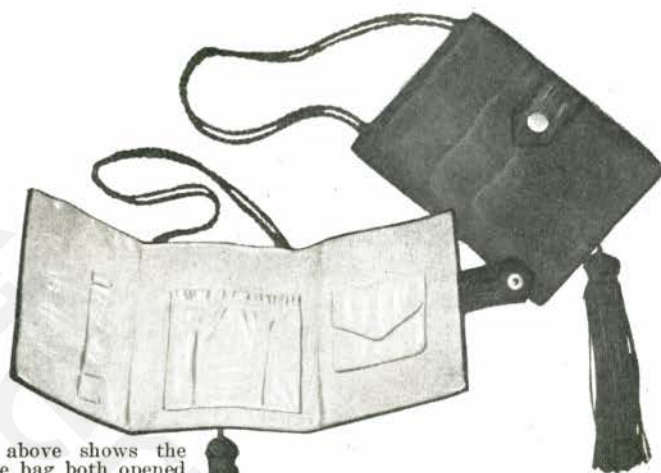

The above shows the envelope bag both opened and closed. It is 6 inches by 5 inches when closed, and requires 18 inches of 6-inch ribbon to form the outside. The inside is made of a lighter shade of ribbon and requires the same amount as the outside of the bag, with an extra  $\frac{1}{4}$  yard for the three pockets. A tassel decorates the bag. The flap which fastens it is made of 2 inches of ribbon.



The above bag is made of figured ribbon. It requires 2 lengths, 9 inches wide by 10 inches long, and the same amount of plain ribbon for the lining. The design is outlined in steel beads.



Bag of ribbon shirred and ruffled. Use 1 yard of 9-inch ribbon for bag and 1 yard of 1-inch ribbon for draw-strings. Decorate with cherry clusters.



The above bag is 7 inches wide by 10 inches long and requires 20 inches of ribbon 7 inches wide. Several plaits are made at top where bag is fastened to frame. Handle is made of  $\frac{1}{2}$  yard 1-inch ribbon.



The fashionable bag above is made of ribbon 8 inches wide. 20 inches is needed for entire bag, the top of which is slightly gathered to fit the frame.  $\frac{1}{2}$  yard of 1-inch ribbon forms the handle.

## THE PRIDE OF THE HOME BEAUTIFUL—LINENS WITH A RIBBON TOUCH

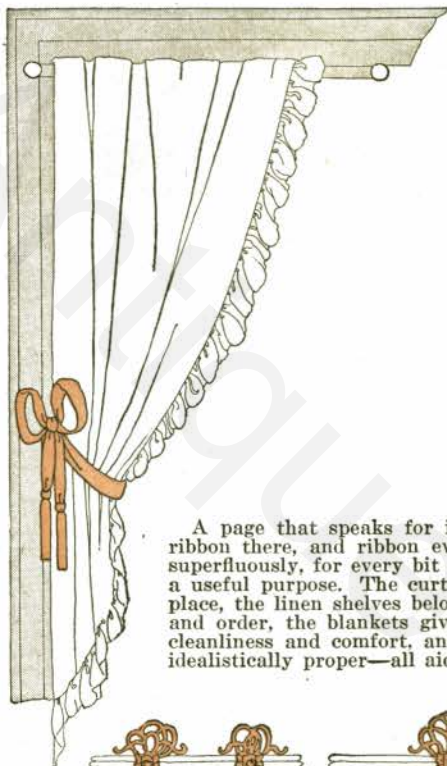

A page that speaks for itself! Ribbon here, ribbon there, and ribbon everywhere. But not superfluously, for every bit of it is here to serve a useful purpose. The curtain above is held in place, the linen shelves below speak of neatness and order, the blankets give one the feeling of cleanliness and comfort, and the linen closet is idealistically proper—all aided by ribbon.

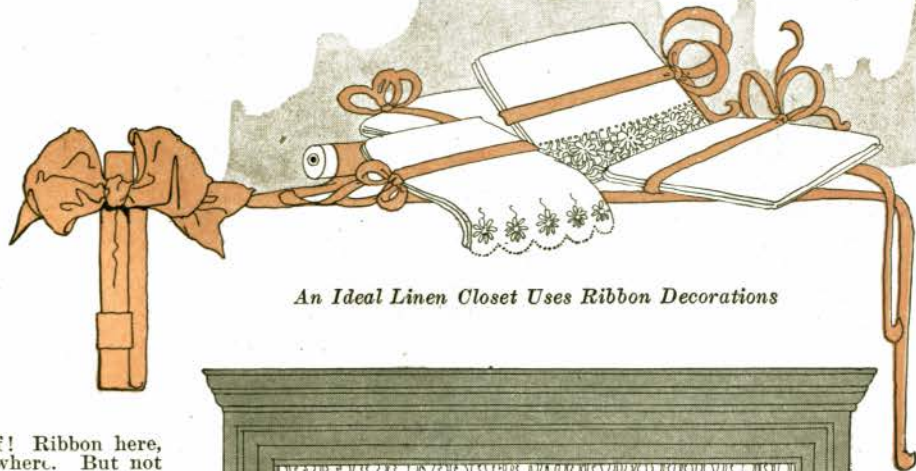

*An Ideal Linen Closet Uses Ribbon Decorations*

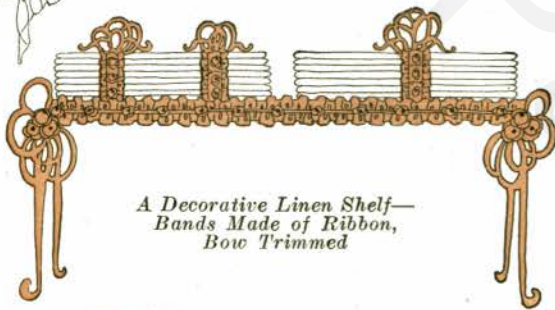

*A Decorative Linen Shelf—  
Bands Made of Ribbon,  
Bow Trimmed*



*More Simple Bows to Tie Linen—  
Tailor-made Bows and Streamers  
Decorate Shelf*

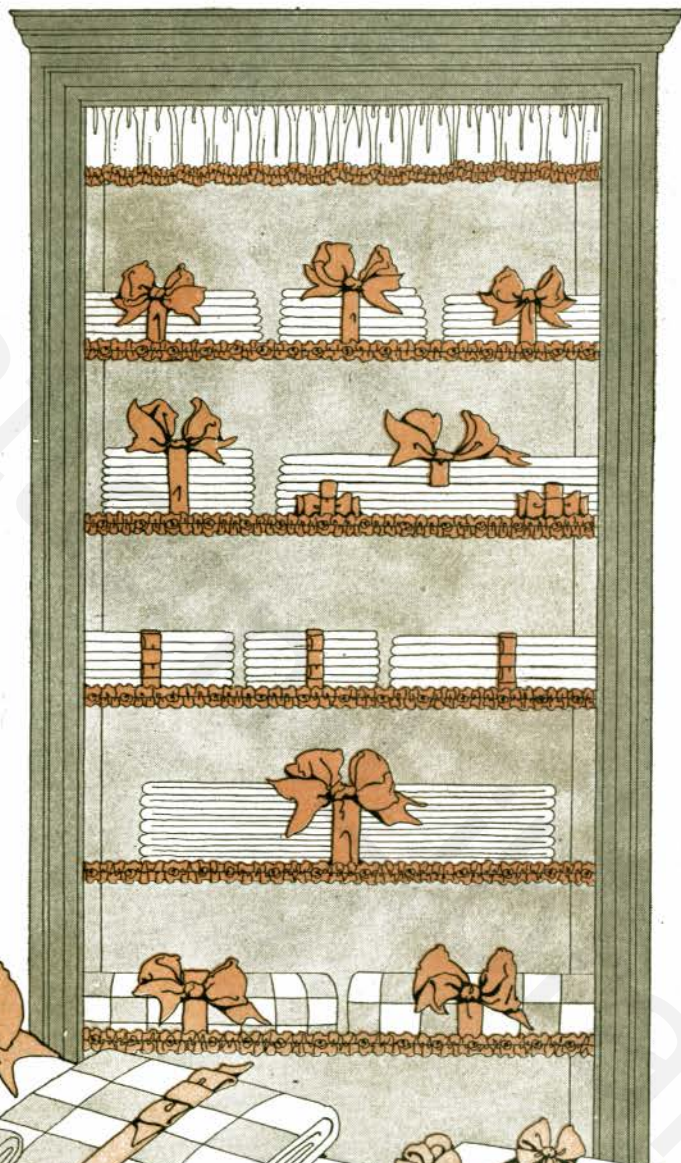

A bow of ribbon or a little bud is often all that is necessary to add the missing touch. Learn how to make these artistic links. Drawings of buds, etc., are described in detail, and illustrated on pages 38 and 39. Bows on pages 15 and 16.

## LAMPS AND PILLOWS FOR THE BOUDOIR



It is called a Jack Rose Lamp and requires:  $4\frac{1}{2}$  yards of 2-inch ribbon, each petal 4 inches long (see page 38); 1 yard of 6-inch ribbon is used to cover stem and base.



The lampshade above has 3 panels measuring 6 inches, and 3 panels of 3 inches. The height of each panel is 6 inches. Each wide panel is covered with  $\frac{1}{3}$  yard of the 3-inch ribbon gathered on frame horizontally. Narrow panels gathered vertically.  $2\frac{1}{2}$  yards of  $\frac{3}{4}$ -inch gold metallic ribbon is used for trimming, tacked down at every inch. The front panel is decorated with leaves and flowers.

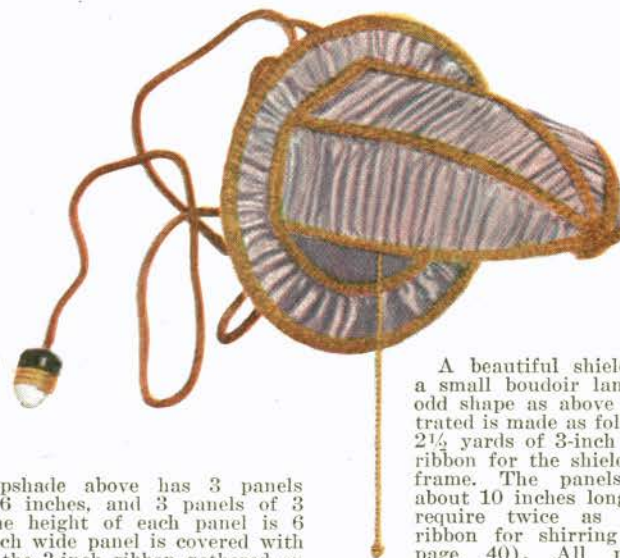

A beautiful shield for a small boudoir lamp of odd shape as above illustrated is made as follows:  $2\frac{1}{2}$  yards of 3-inch satin ribbon for the shield and frame. The panels are about 10 inches long and require twice as much ribbon for shirring (see page 40). All panels meet in a point at end.  $\frac{3}{4}$  yard of 2-inch ribbon for the frame; 5 yards of gold braid for trimming; 4 yards of  $\frac{1}{4}$ -inch ribbon to cover frame (see page 48).



The lady above forms a pincushion and she requires for her dress-up: 2 yards of 6-inch ribbon for dress, 3 yards gold lace for trimming skirt and bodice, 3 yards of  $\frac{1}{4}$ -inch plaited ribbon for ruffle on cushion. 1 yard of narrow gold braid for edging cushion.



Another charming round pillow is illustrated above and matches the basket and lamp shown on page 46. The pillow is 18 inches in diameter.  $8\frac{1}{2}$  yards of 5-inch ribbon is shirred for front, requiring 2 widths of the ribbon. The back is plain.  $2\frac{1}{2}$  yards of 6-inch ribbon is cut in 3-inch squares and folded and gathered, forming the wheel-like motif (see diagrams to the right). The motifs are connected by means of metal threads.  $\frac{1}{2}$  yard of 5-inch ribbon in a contrasting color is used under the open-work formed by the wheel fancies.



Strip of Ribbon Shirred



Rings Fastened with Metal Threads



The above telephone cover is made with 5 yards of 9-inch ribbon for costume and 8 yards  $\frac{3}{4}$ -inch ribbon for trimming.

Choice of Buds and Flowers are found on pages 38 and 39, and Rosettes on pages 15 and 16.

BOUDOIR LAMPS AND PILLOWS USE MUCH RIBBON



*This Lamp Favors a Long, Flary Skirt*

A lamp shield is covered and upon it is mounted a bisque doll. A bodice is draped with 9 inches of double-faced satin ribbon 6 inches wide, bound at the neck and sleeves with gold lace 1/2-inch wide. Around the waist a double skirt is gathered, made of 1 yard each of 3-inch and 4-inch taffeta ribbon, edged with the gold lace. The skirts are lifted in back of the figure and placed around the outer edge of the shield.



*A Small Pillow with Wide Ruffle and Tassels*

The pillow above is 10 inches square: 2 1/2 yards of 6-inch ribbon is used for the ruffling—4 separate pieces, 1 for each side, cut bias at ends where they are sewed together. 4 yards of 2-inch gold metallic ribbon outlines the bottom of the ruffle. 2 3/4 yards of 1/2-inch gold metallic ribbon is used on seams at side and for outlining the top of pillow on seams (see diagrams below for method of shirring). 16 buds decorate the outline of pillow.

*A Half Circle Makes an Odd Cushion*



The half circle cushion above will fit in wherever a little more comfort is wanted. The top measures 21 inches. The lining is made with 3 strips of 7-inch ribbon. 8 yards of 2-inch picot-edge ribbon is required for the cushion. 6 ruffles of shirred ribbon are used, the top and smallest placed around a half circle, 6x4 inches. Each row requires 7 to 9 inches more ribbon than the preceding row. 2 yards of 1/2-inch velvet ribbon made into streamers and bows to decorate the top.

*Lace and Shirring Give Tone to This Round Pillow*

*Charming Pillows Favor Flowers and Buds*



A pillow of beauty and comfort is found in the above. It is 15 inches in diameter. 2 1/2 yards of 4-inch ribbon is corded and shirred around a center circle of ribbon 8 inches in diameter. A ruffle of 1 3/4 yards of 4-inch ribbon, allowing 1/2 inch on top for ruffling, is shirred and placed around the circumference. 1 1/2 yards of 7-inch ribbon lines the pillow.

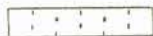

Placing of stitches for shirring above.



Shirring tacked on either side.



The boudoir pillow above is made of 6 yards of 6-inch moire ribbon. The center has 4 triangular inserts with shirring of baby ribbon in the seams. 1 1/2 yards of scalloped cream lace is placed around the circle formed by the inserts. Shirred baby ribbon also outlines the lace. A ruffle of moire ribbon is placed around the circumference. 3 pieces of baby ribbon is required for the shirring.

For details of Buds and Flowers, see pages 38 and 39. For Rosettes, see pages 15 and 16.



## LITTLE BELONGINGS OF THE BOUDOIR

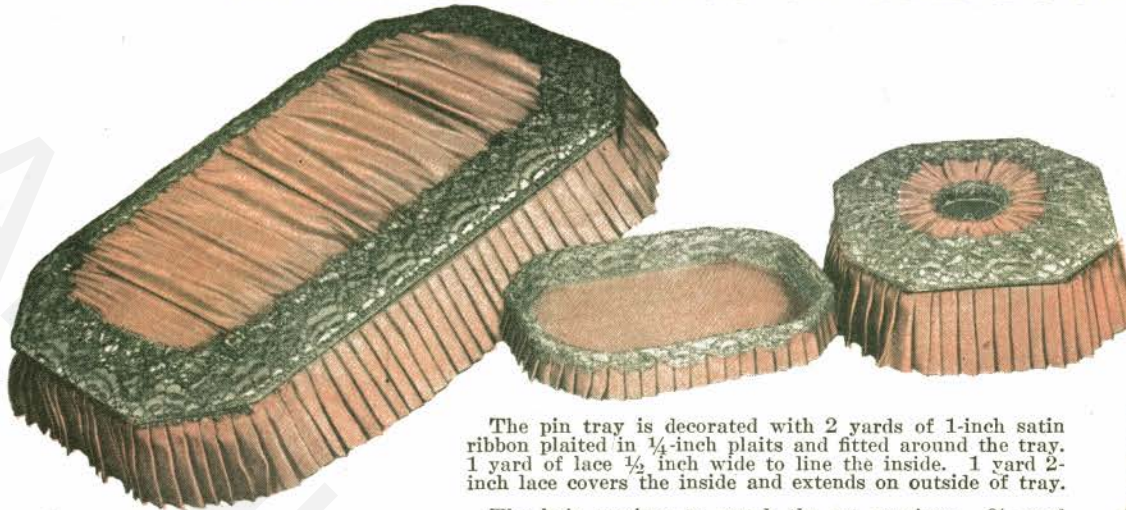

As charming as the dainty handkerchiefs which it holds, is this box:  $\frac{1}{2}$  yard 6-inch satin ribbon for top; 3 yards 2-inch satin ribbon formed in  $\frac{1}{4}$ -inch plaits around box. 1 yard 2-inch gold braid for top.

The pin tray is decorated with 2 yards of 1-inch satin ribbon plaited in  $\frac{1}{4}$ -inch plaits and fitted around the tray. 1 yard of lace  $\frac{1}{2}$  inch wide to line the inside. 1 yard 2-inch lace covers the inside and extends on outside of tray.

The hair receiver to match the set requires:  $\frac{3}{4}$  yard  $2\frac{1}{2}$ -inch satin ribbon for top cover;  $1\frac{1}{2}$  yards 2-inch satin ribbon forming  $\frac{1}{4}$ -inch plaits for sides;  $\frac{3}{4}$  yard lace around top;  $\frac{3}{4}$  yard lace for the inside and extending over top.

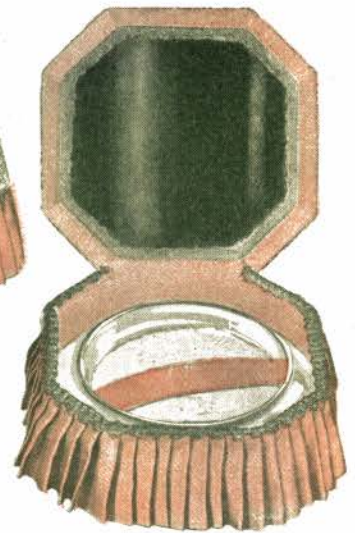

And that most important item—the powder box! It requires:  $\frac{1}{2}$  yard 4-inch satin ribbon for cover;  $1\frac{1}{2}$  yards  $2\frac{1}{2}$ -inch satin ribbon plaited for sides; 1 yard of lace outlining top.

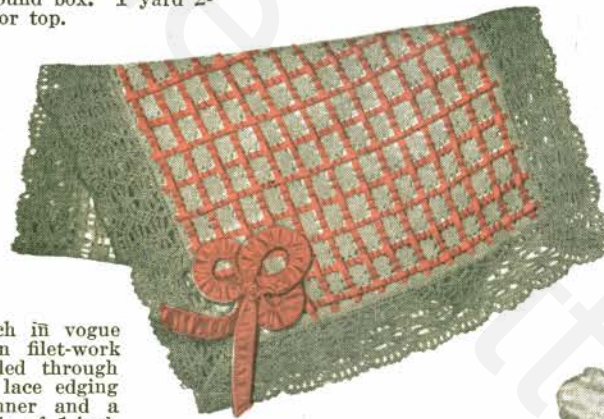

A runner much in vogue is made of open filet-work with ribbon pulled through the meshes. A lace edging outlines the runner and a bow of  $1\frac{1}{2}$  yards of 1-inch ribbon is shirred and trimmed with buds to decorate the corner.



To make the hanger illustrated above one requires but little time and material. The hanger is 18 inches long and 3 inches wide.  $\frac{1}{2}$  yard of  $3\frac{1}{2}$ -inch ribbon is required for each side, decorated with 2 tiny bows requiring 2 inches of baby ribbon.  $1\frac{1}{2}$  yards of  $\frac{1}{4}$ -inch baby ribbon is used to cover hanger and base. Decorate with bow.



The scrap-basket to the left matches the lamp above and will add usefulness and decoration to the boudoir. The circumference at the top is 9 inches, bottom 12 inches, and  $13\frac{1}{2}$  inches high. 7 yards of 6-inch satin ribbon used for the outside, shirred on top. 3 yards of 5-inch ribbon is used for the lining. 5 yards  $\frac{3}{4}$ -inch satin ribbon is braided to form the two handles.  $11\frac{1}{2}$  pieces of  $2\frac{1}{2}$ -inch ribbon used for the wheels which are 1 inch in circumference (for diagram see page 44). 1 piece (10 yards) of  $\frac{1}{2}$ -inch ribbon for covering frame (see page 48 to cover frame).

The lamp above to match the basket is made as follows: 2 yards of 5-inch satin ribbon for the dress. 3 yards of 3-inch ribbon for the wheel trimming. 1 piece (10 yards) of  $\frac{1}{2}$ -inch ribbon for covering frame.



The attractive sachet case below is made of  $\frac{3}{4}$  yard of 4-inch ribbon shirred around a cardboard circle of 8-inch diameter. Carry ribbon over to reverse side and gather it around a 3-inch circle of ribbon. The front is formed with strips of  $\frac{1}{4}$ -inch ribbon, each 7 inches long, 7 strips of each of 4 colors alternate to form the front. The inside is padded with wadding and the outside is decorated with leaves and buds.



The pages of the "Ribbon Art" book open a store of useful knowledge for all home lovers and fashion seekers. Have one always within reach.

For detailed drawings and descriptions on Flowers and Buds, see pages 38 and 39.

THERE IS PERSONALITY IN THESE RIBBON CHARMS



The square handkerchief cover is made of 21 inches of ribbon 5 inches wide. The back requires 5 inches of the ribbon, and each of the flaps 4 inches. Both corners of the flaps are turned in, forming triangles which meet in the center. Tiny buds decorate each section.



The circumference of the vanity case is 7 inches. A mirror forms the base and 7 inches of ribbon 2½ inches wide forms the bag, with baby ribbon gathering the top, and ends allowed for drawstrings. 6 petals are made of 7 inches of 2-inch ribbon, doubled. (See page 40.) Buds decorate center and bottom.



The three-sided telephone screen is covered with ⅔ yard of 10-inch ribbon. ⅔ yard of 7-inch figured ribbon is used for triangles and 2 yards of ¼-inch metallic ribbon outlines the triangles. ½ yard of ½-inch ribbon is required for each bow. Buds decorate the top and mouthpiece.



The top of the powder container is made of a cardboard foundation covered with 4 inches of ribbon. ¾ yard of 2-inch ribbon is shirred around circumference of the cardboard and gathered at the top. 1 yard of gold lace is used for trimming.



The sewing case above is made of ⅙ yard of ribbon 5 inches wide, worked on a foundation of stiff buckram. ¾ yard of ½-inch gold metallic ribbon outlines all seams. Snaps are inserted for fastening.



The above box is a charming illustration of beautiful things that can be made of ribbon. The box is decorative and may serve many useful purposes as well. It will hold the dainty handkerchiefs, gloves, veils and other small items that are included in the careful wardrobe. The original box above is ¾ yard long by 12 inches wide and 4 inches high. The top and sides are padded. Ribbon 4 inches wide is shirred for sides and 2 strips of 6-inch ribbon arranged in many folds covers the top. Gold lace binds the cover, top, and bottom of box. The inside is also lined with ribbon.

Effective lampshades are made of ribbon and fringe. The plaiting is made of ½-inch ribbon (see diagram 5, page 40). Panels of 2 contrasting shades of ribbon form the top of the shade. A heavy silk ribbon fringe hangs from the frame. The framework is covered with ⅛-inch ribbon. (See page 48 to cover frame.)



The above doll covers a jar which may hold absorbent cotton. ¾ yard of 7-inch ribbon is used for each ruffle with ¾ yard of ¼-inch gold lace. The 2 bottom ruffles cover a jar of 5-inch diameter, and the top ruffle is placed over doll. Trim with buds.

The lingerie band below is 2 inches wide and ¾ yard long. It is decorated in front with a wheel of lace in the center of which are buds. A catch is inserted for regulating the band.



For choice of Buds and Flowers, see pages 38 and 39. For Rosettes, see pages 15 and 16.

# Detailed Diagrams of Articles Shown on Other Pages

## CHILD'S HAT OF GROSGRAIN RIBBON

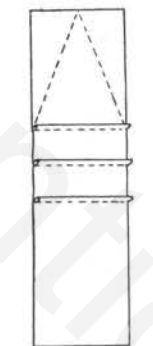

One of the Sections Used for Crown (Dotted triangle shows where sections are joined)

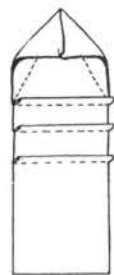

Same as 1 with Ends Lapped Over to Form Plaiting on Top of Crown

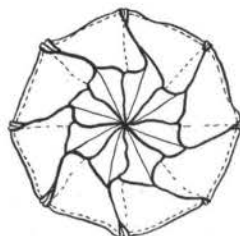

Showing Top of Crown

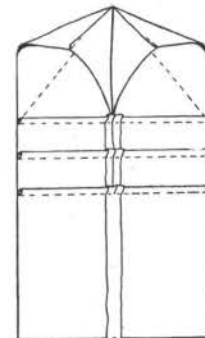

Two Sections of Ribbon Attached for Crown



Showing Brim

The Charming Hat Detailed Above Is Illustrated Picturesquely on page 22

Wearing apparel for children made of ribbon is attractive and adds real charm to the young "Miss." A hat like the one illustrated above wears well and is suitable for any season.



WILD ROSE

Roses form an effective trimming, and are easily made. The stamens around which the petals are placed can be purchased in a millinery supply department.

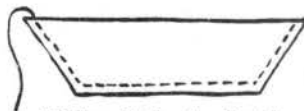

Ribbon Strip for Petal, Showing Stitching



Shirred Petal



Petals Connected to Form Rose

## PUMP BOW



Finished Bow



Ribbons Placed in Position

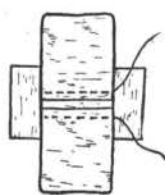

Wide Ribbon Sewed as Desired



Back of Finished Bow

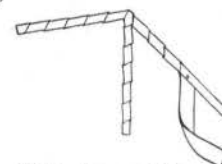

Wire Frame Covered with Ribbon

The above covering is used generally on lampshades, baskets, and all other articles that are worked on a wire frame which is not otherwise covered in the workmanship of the article.



A Rolled Bud Made of One Strip of Ribbon.

These buds are commonly used for decorating. While working, roll the ribbon to form the petals. See negligee on page 13.

## SLIPPERS MADE ECONOMICALLY WITH CUTAWAYS USED FOR BACK (illustrated on page 11).

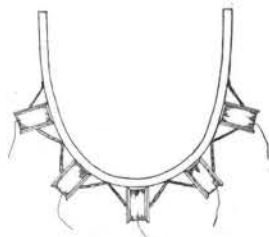

Back of Sewing Doll on page 4

Showing Loops on Hoop for Spools of Cotton

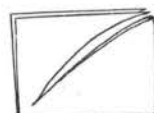

Showing Ribbon Folded and Cut

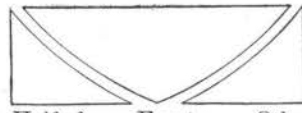

Half of Back Front Other Half of Back

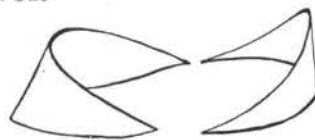

Front Back

Showing Position Ribbon is Placed on Sole to Form Slipper

## SIMPLE LEAF WITH WIRE VEIN



Ribbon Cut Diagonally



Wire Vein Inserted



Leaf Open Back View



Finished Leaf



*Interior Decorations to be Smart Display Much Ribbon—For Details on Lamp, Pillow, etc., See Foregoing Pages*

# RIBBON ART



**RIBBON BLOSSOMS!**—they rival nature's own blooms. A corsage on an evening gown, beautiful flower trimming on hats or dresses, tiny buds on baby things or lingerie, flowers throughout the home—and all of ribbon!

You, yourself, can easily make every flower in this bouquet. Beginning with page 38, you will find full and definite instructions on how to create each flower from petal to full bloom.