

The
H
A
N
D
I
C
R
A
F
T
E
R

Creative Commons 4.0 NC SA BY FREE DISTRIBUTION ONLY - NOT FOR SALE

March-April
1930



Price
Forty
Cents

www.antiquepatternlibrary.org 2020.02

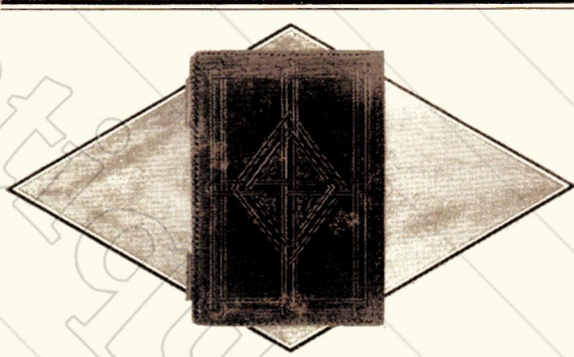

Leathercraft the "Family Craft"

USEFUL articles are easily completed by any member of the family and the work is neither complicated nor involved. Writing folios, bridge sets, book covers, hats, cigarette and card cases, bill folds, purses and hundreds of other decorative and serviceable articles of leather can be made to which your own personal touch is added.

We furnish the leather already cut to shape and size—you assemble and decorate it according to our complete patterns and simple

instructions. We supply you with the tools, dyes, laces—everything necessary in Leathercraft.

We also supply leather in the whole skin to hospitals and schools conducting classes in Leathercraft.

Send your name and address with 25 cents in stamps for "Leathercraft" a 124-page instruction book which contains instructions and descriptions of hundreds of useful items you can make from our leathers.

ADDRESS DEPARTMENT F 30
GRATON & KNIGHT COMPANY
WORCESTER, MASS.

HAMMETT'S

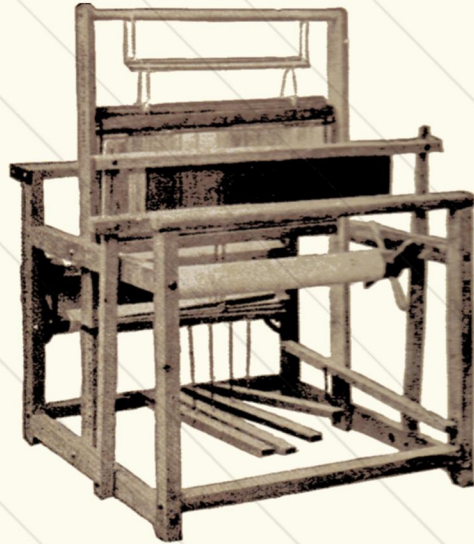

The "Tawido" Belt Loom is one of the many types offered in our weaving catalog.

Send for free weaving and art material catalog; also free Basketry catalog

J. L. HAMMETT & CO.

Established 1863 CAMBRIDGE, MASS.

A Course of Lessons in HANDWEAVING

This series of three lessons by Misses Snow and Peasley is designed to be of practical instruction to the beginner and an ever valuable guide and source book to the experienced weaver.

It is written in a comprehensible style, commences with the A.B.C.'s of the loom and weaving, is illustrated with diagrams and is authoritative.

Every craft has its right and wrong ways; with this course you are guided in the correct paths and have before you in lucid style weaving from the loom to the creating of the fabric.

PRICE \$6.00 POSTPAID

Orders will be filled promptly by

The HANDICRAFTER

JAMAICA PLAIN

MASSACHUSETTS

Willa-Craft Studios

CECELIA CLEVELAND WILLARD

30 East 14th Street
New York City

▼
Hand Loom Weaving taught in all variations
Tapestry and Modified Tapestry
Embroidery and Laid-in Weaves
Colonial and Swedish Pattern Weaving
Warping and Mechanics of the Loom

▼
SPECIAL COURSE

for those wishing to make a profession
of Weaving

Working knowledge of weaving is guaranteed
at the completion of the course of 12 lessons

CIRCULARS MAILED UPON REQUEST

March
April
1930
Vol. II No. 3

THE HANDICRAFTER

\$2.00 per year
40 cents per copy
Canada and Foreign
\$3.00 per year

MARJORY AMES
Boston, Mass.

PAUL BERNAT, *Editor*
Associate Editors
ELLA S. BOWLES
Franconia, N. H.

PAULINE SCHINDLER
California

☞ THE HANDICRAFTER welcomes contributions of articles with or without photographs or illustrations. To get the best results for reproduction, photographs should be on glossy paper and drawings must be in India ink.

☞ The publishers can assume no responsibility however, for the safety of either manuscripts or photographs, though due care will be exercised in their return if considered unavailable.

CONTENTS

Editorial	2
The Sampler <i>Mildred Mowll</i>	3
Southwestern Arts <i>Paul Bernat</i>	8
Hand Made Book Ends	12
This Modernism <i>Robert F. Heartz</i>	14
A Craftsman Influences a City <i>Pauline G. Schindler</i>	19
The History of a Race Is Told by a Modern Craftsman in Wood <i>Pauline G. Schindler</i>	21
Filet <i>Louise Austin Chrimes</i>	22
A Clipping or Filing Case <i>Edith P. Fetterolf</i>	25
Some Novel Weaves for the Ensemble <i>Nellie Sargent Johnson</i>	27
Spool and Box Furniture <i>Marion Brownfield</i>	31
The "Ensemble" Idea in Hand Woven Linens <i>Cecelia Cleveland Willard</i>	33
Looking at the Crafts	39

Published six times a year by Emile Bernat & Sons Co., Jamaica Plain, Massachusetts. Printed in U. S. A.

When Looking for
That Other Loom!

Write us

IT'S A LANE

Nuttelman Mfg. Co.

209 North Main Street
FLORENCE, MASS.

Leather Craft
Correspondence Course

ILLUSTRATED BY TOOLED AND
COLORED LEATHER SAMPLES
ALSO PATTERN DRAFTS

The text covers leather craft from its rudiments through the higher stages. It gives detailed instruction in tooling, stamping, coloring, and the finishing of leather pieces.

Also Hillside dyes for leather.

Send for circulars

The HILLSIDE STUDIO

(Mrs. Miriam B. Pearce)

185 NEWTONVILLE AVENUE
NEWTON, MASS.

Editorials

THE recent exhibition of modern English and Japanese weavings that was held in Cambridge, Mass., and a perusal of its announcement circular leads the editor to wonder whether all of us realize what is hand crafting and what components lead to artistry and durability.

In his foreword, Mr. Yanagi says: "Nothing is good unless it is made of materials best suited for their purpose, prepared and treated in the most healthy manner, in other words, in such a way as to obtain from them a maximum of durability in use and at the same time the fullest expression of the beauty which is inseparable from quality of texture, goodness of workmanship and creative ability of the designer."

The editor whole-heartedly concurs in these premises, but after viewing the exhibit I have wondered whether Mr. Yanagi does not lead the on-looker astray by painting such glowing words as the foreground for such a disappointing exhibit. The inevitable conclusion is that Mr. Yanagi believes these weavings fulfil the premises he has laid down as regard the essence of good craftsmanship; the writer does not think so and goes so far as to consider the elements of their structure as a possible menace to the welfare of modern crafts.

Many of the weavings displayed were of hand-carded and handspun wools dyed in vegetable colors. Little pattern weaving was displayed; most of it was plain color or in arrangements of striped masses, whose monotony was relieved by the play of color. The weavings showed little relation to utility; there were strips that might be table scarves and then again might be apparel scarves or hangings. The weaving itself was mediocre with a prevalence of pulled edges, uneven beat, and unharmonious color arrangements. The Japanese weavers were most flagrant in their disregard of the amenities of the art.

In describing the craftsmen represented in the exhibit, Mr. Yanagi tells of Mrs. Phillippe Mairet, at whose studio "the entire routine of carding, spinning, dyeing, and weaving on hand looms is carried on by herself and pupils." To the writer there is nothing commendable in this, though it may be an attractive sight for the tourist. I doubt if Monsieur Rodier, the great French textile designer, conducts carding, spinning, or dyeing rooms in his establishment, yet I venture to say

that his weavings are much the greater and that as an artist he ranks far higher than Mrs. Mairet.

In people like Mrs. Mairet is embodied a repercussion of the urge to revert to the primitive and in its motivation is akin to the spirit that actuated William Morris and the Pre-Raphaelites. These men felt that there was something wrong in their age, that art was languishing, and that the only way to revive its drooping spirits was to hark back to the age of Giotto and Fra Angelico. They did not realize how vastly different was the environment of fourteenth- and fifteenth-century Europe from that of the nineteenth-century industrial era, and that no ground of meeting could possibly exist. Also men like William Morris and Ruskin looked at the Medieval periods through a mistaken light and went astray through the beckonings of that universal failing which tells us that the past is better than the present.

There is nothing to prove that the crafts of the past were great because their masters went through all the processes the art involved, and in the crafts themselves there is nothing that requires this drudgery. Good materials are but an instrument and their value can be wiped out in the processing; this is true of the exhibit discussed. Also it is true now and was in the past that the best materials come from specialists in their production. To the writer's mind a gifted craftsman who spends her time in these manual processes is exhausting her creative energy and is not living up to a sincere craft spirit; just bending towards primitivism. The carding of wool is a mechanical operation that should be shifted to the machine or a manual worker. In Colonial America the children had this duty devolved on them; in the Renaissance it was let out to home workers by entrepreneurs or carried on in the wool merchant's factory. Yet these are the periods to which these people refer when justifying themselves.

The same is true in spinning, dyeing, and other processes in the textile arts. The making of tapestry in Brussels, which was the greatest of tapestry weaving centers, is an illustration in point. The first step was the designing of the tapestry for which the artist made a preliminary sketch. When this was accepted, his pupils elaborated it in a scale and colored cartoon which the weaver followed.

(Continued on page 44)

The Sampler

BY MILDRED MOWLL

THE sampler as a pattern, or example, from which to learn or copy varieties of needlework, whether of design or of stitches, must be as old as the art of embroidery itself. However, it does not become familiar to us until comparatively recent times.

In the sixteenth century, when men's clothes as well as women's were encrusted with embroidery, everyone worked with a needle. The women folk had ample leisure and there was little else to provide relaxation. The use of embroidery was not confined to personal adornment, but was employed in the various objects which went to make up the furniture of the house, such as curtains, bed hangings, table cloths, chair coverings, cushions, caskets, books, purses and even pictures. The luxury of the house and household increased to an extent that called for large numbers of each article, whether clothing or table or bed drapery. Identification by marking and numbering as well as decoration became a necessity, and as the limited libraries seldom contained books of designs, ornamental lettering and numerals, samplers were made to furnish them.

The evolution of samplers is easily traceable: first of all decorative patterns without definite arrangement on a piece of linen, merely a memorandum; then designs in orderly rows making a harmonious whole; then later added alphabets and numerals for the use of those who marked the linen; and then imitations of tapestry pictures by the addition of human figures, houses and the like; finally adopted as an educational task in the Dame school in the colonies as a specimen of phenomenal achievement at an early age, and as a means whereby moral precept might be prominently advertised by young and old.

The dated samplers which have survived are not much more than two hundred and fifty years old, but they are in themselves evidence that the sampler was already a fully developed growth and the descendant of a long line of ancestors. That they were in vogue long before this is proved by reference to them in literature as articles, the use of which was quite commonplace.

The early samplers presented but little of the regularity of design which marks the later ones. The work of brides-to-be and housewife, they were made solely for use as a pattern sheet and not for

their own decorative quality. Each needlewoman borrowed from her neighbor the designs which pleased her and made notes of them on her sampler, which was an integral part of the contents of every bride's dower chest. Many strange designs, apparently gathered from the four corners of the universe, were found on these bits of linen, including the human figure, although it was by no means common in early examples, animals, many flowers and fruits, the rose, carnation, honeysuckle, strawberry, fig, pineapple, tulip, oak tree and acorn, and many others, also the crown and coronet and coats of arms on English samplers.

Soon there were added to the monotony of the alphabets the maker's name, the year, a wise or pious saying and finally flights into moral or religious verse. As the eighteenth century advances we find verses coming more and more to the fore, and in some cases they were scarcely distinguishable from prose.

With the introduction of verse, names and dates the sampler became more and more the product of youthful hands. Before 1700 the age of one maker is mentioned thus: "Mary Hall is my name and when I was thirteen years of age I ended this in 1662." After 1750 almost all samplers bore the age of their originators, and almost half of the samplers which have come to us from that time were worked by tiny tots not yet ten years of age. One young lady of six worked on hers:

"When I was young
And in my prime
Here you may see
How I spent my time."

In America the sampler was at first simply a continuation of the English form. The oldest was made by Anne Gower, who became the wife of Governor Endicott, and who, with many of our pilgrim mothers, brought her sampler with her to her new home. Our first really American sampler is that of Loara Standish, daughter of Miles Standish. She made a beautiful sampler in blues and browns with many intricate designs. Nearly all the early American samplers that have come down to us were made in New England.

Toward the end of the seventeenth century in America the sampler was growing wider and shorter and number and intense intricacy of the designs was decreasing. The busy life of the colonies



A group of antique samplers in various styles

Courtesy of the Metropolitan Museum of Art

left little time for the elaborate adornment of the household linen and clothing, so the need for a compendium of patterns and stitchery died out and samplers of this kind became fewer.

After this decline of the earlier type — the long narrow sampler with many bands of patterns — there grew up a new sampler type for a different purpose. The colonies provided some schooling for the boy — many of the schools founded at that time are famous educational institutions today — but it was not until after 1800 that any definite effort was made on the part of the government to provide for the girls as well. Meanwhile a girl's education was considered quite finished when she could read the New England Primer. But there did exist at that time two types of schools where girls were taught, the Dame school and the finishing school. The Dame school was very indefinite in its make-up — merely the children of the neighborhood meeting at some house where classes were held in the kitchen or in tiny log schoolhouses. In most of these the horn-book was the only textbook,

the primer from which the child was taught and which obviously served as a pattern for the simple samplers made at these schools. These samplers were often merely rows of letters separated by a row of stitching with the maker's name, age and the date. Sometimes a simple rhyme was concealed in the even rows of letters.

Meanwhile the finishing school grew up. Apparently Boston, Newburyport and Salem were the centers of the school in Massachusetts. There were many schools of this type and evidently the making of samplers was a part of their system of education, for we have many most charming examples from their young ladies. The samplers grew to be more elaborate and began to show marked originality and individuality. Actual borders all around a shape, nearer square than formerly, appeared. These borders were usually quite simple in form, strawberries, acorns, Greek frets and occasionally a freely drawn vine.

One sampler shows a ground of one hundred diamonds embroidered with the multiplication tables. Perhaps Mary Ellis, who made it, needed coaching in her arithmetic.

Now instead of copying, as before, any except the minor forms, such as the border, small spots of design, the letters and numerals, the main design was largely original with the worker herself, or with her parent or teacher, so that the variety is endless. And so, having Nature as a model and much imagination, we have a whole new and strange world presented to us; a conglomerate mixture of animals, birds, trees, houses, baskets, flowers, fish, human beings and anything else under the sun that the young embroiderers saw fit to include, and always without the slightest regard for scale or growth. Often a shepherdess appears who is at least three times as big as her house, and then again her sheep are so large that they might swallow her whole without the slightest inconvenience. Sometimes



Courtesy of Boston Museum of Fine Arts

Sampler, XVIII Century

the faces of the personages represented are embroidered, but not frequently, because the linen used for the background was coarse and the delicate features of a shepherdess were difficult to render on such a background; more often they were painted or appliqued, or both, and sometimes they were adorned with a lock of hair from the person they were to represent. About 1740 someone conceived the idea of using Adam and Eve as a sampler subject, and there follows a long line of marvelous Adams and Eves and still more marvelous serpents, usually very stout and always with a most intriguing expression. The apple trees above are laden with fruit of such a size as to make modern farmers green with envy, and the costumes of our common ancestors vary from large and modest fig leaves to Quaker garb and elaborate costumes of the very latest fashion. Indeed sometimes it would be impossible to identify them were it not for the fact that they are often labelled.

There were fashions in samplers as in everything else and an idea often spread gaining form and character as it went. Family trees, preserving the records of two or three generations, long Biblical texts on tablets, representations of the dwellings of the workers and many public buildings, all these were popular subjects in their time.

During this period sampler verse reached its height. This is quite unique in its extreme quaintness and although many of the verses are mere repetitions and others Biblical texts, quotations from hymns, and the more pious of the poets, a few are worthy of notice as characteristic. One of the common types follows:

"Susannah Gorham is my name
And with my needle I wrought the same
And if my skill had been better
I would have needed every letter."

Another very common form:

"Mary Ellis is my name
New England is my nation
Greenland is my dwelling place
And Christ is my salvation."

Often these verses were very gruesome, imagine any healthy active child spending hours over this!



Courtesy of Boston Museum of Fine Arts

Sampler, XVIII Century

"My thoughts on awful subjects ran
Damnation and the dead
What horrors sieze the guilty soul
Upon a dying bed.
Lingering about these mortal shores
She makes a long delay
Till like a flood with rapid force
Death sweeps the wretch away."

But there are many pleasanter though none the less moral precepts wrought by these small hands.

These samplers became more and more pictorial until they were hardly more than needlework pictures, and these in their turn suffered decline with the other minor arts through the latter part of the nineteenth century.

Today the sampler still appears sometimes as a frank effort to copy the old but often to serve a new and unique purpose: to commemorate and preserve the atmosphere of some historical event; to express the character and history of some town; to sanctify the building of a home and to preserve



Sampler, XVIII Century. Collective type. Group of patterns for future use



Sampler, XVIII Century. (Upper left) gros point. (Upper right) Florentine stitch. (Center) petit point. Other figures in long and short, split stitch and satin stitch. Samples at bottom are of cross stitch, Hungarian point, Florentine stitch

for its children the beauty of its family life; or to mark for remembrance any one of a number of intimate anniversaries such as engagements, commencements, weddings. Although these samplers may differ radically in purpose, character of design and color and even workmanship from those of our grandmothers' and their grandmothers', they are still samplers and they still hold for us the charm that surrounds the tradition of the sampler.

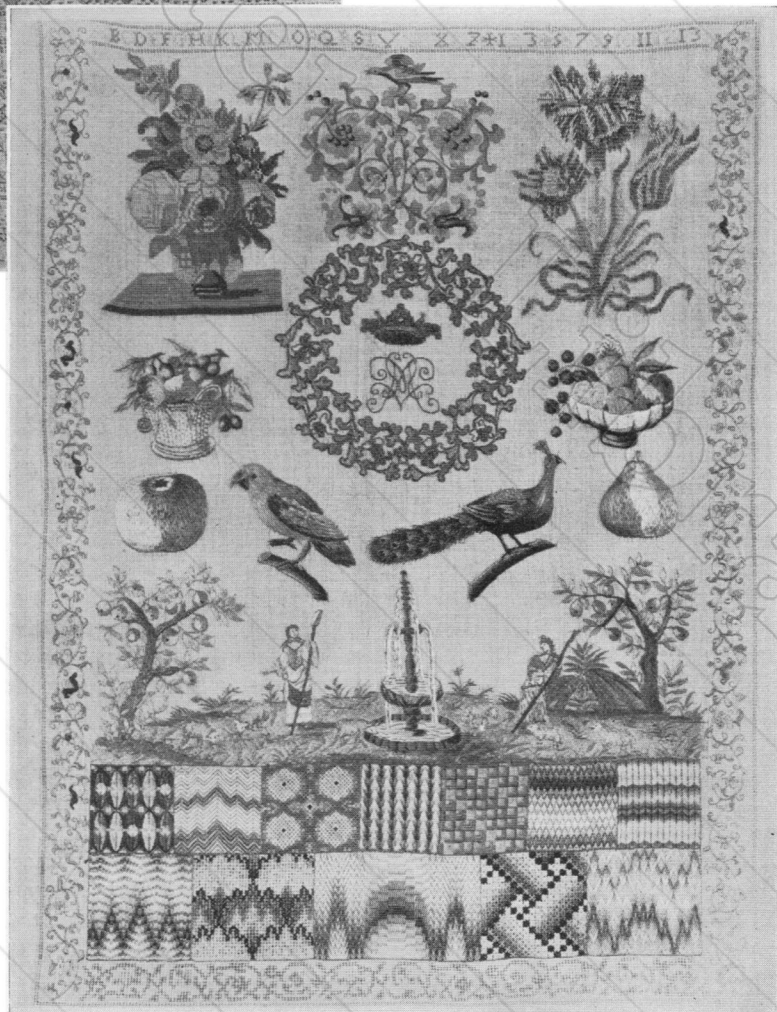

Courtesy of Boston Museum of Fine Arts

Southwestern Arts

BY PAUL BERNAT

THE actual craft methods and the peculiarities of the various Indian arts are interesting. To discuss them adequately would require too much space, so this subject is being deferred for a later article. In this preliminary article the author's desire is to point out the foundations of art in the Southwest, handling perfunctorily the Pueblo Indian and the Spanish Colonial phases.

Spanish Colonial to most people represents a new branching in art history. The Spaniards entered New Mexico in the sixteenth century. The first comers were the conquistadores like Coronado, but later in the century permanent settlements were founded, the first of these under the leadership of Oñate. There exists much misapprehension about the Spaniards and the treatment they accorded the Indians. It is undoubtedly true that predatory and rapacious treasure seekers like Coronado were cruel to the Indians, made slaves of them, and committed massacres. But not all the Spaniards were of this sort and, after the great Indian rebellion of 1680, the attitude of the Spanish was radically changed. From then on the Spanish Fathers and settlers lived side by side with the Indians in an amicable way, aiding them in their defense against marauding tribes and helping them improve their material lot. Mr. Herbert Spinden, the great American ethnologist, believes that the Pueblo Indians were much better off under the rule of the Spanish than they would have been under the English or pioneer Americans, and he believes their survival can be ascribed to the fact that the Spanish settled in the Southwest



Courtesy of Frank G. Applegate

Table — Spanish Colonial

ahead of the Anglo-Saxons. No incident of cruelty in the Spanish phase of their history outmatches the expulsion of the Navajo from their homeland in 1863. The United States Government forced them to depart without any of their belongings or flocks of sheep, which were the bulk of their wealth, and placed them in an inhospitable country in New Mexico. The tribe had almost perished before the arousing of popular sympathy and common sense prevailed on the Government to reestablish them in a congenial homeland. The story of this act of maltreatment is vividly narrated in James' "Indian Rugs."

The Spanish are an assimilating race and do not draw the severe color lines that the Anglo-Saxon does. They met the Indians on common

ground, appreciated the beauty in their arts, realized the suitability of their mode of architecture and farming for the terrain. Though the Mission Fathers proselytized the Catholic faith and did succeed in converting the Indians to Catholicism, they left their ancient customs and ceremonies unmolested, and today we find Indians practising both religions, perhaps not for the future benefit of their souls but certainly for present well-being in mind. Earle R. Forrest in his book, "Missions and Pueblos of the Old Southwest," says: "The Spanish did not treat them like a conquered race; but gave them every opportunity and helped them. . . . The priests did not take the sword with them into the desert; their only weapon was the Cross, and many of them paid with their lives before the Indians understood their new religion. . . . The



Marriage Chest — Spanish Colonial

Courtesy of Frank G. Applegate

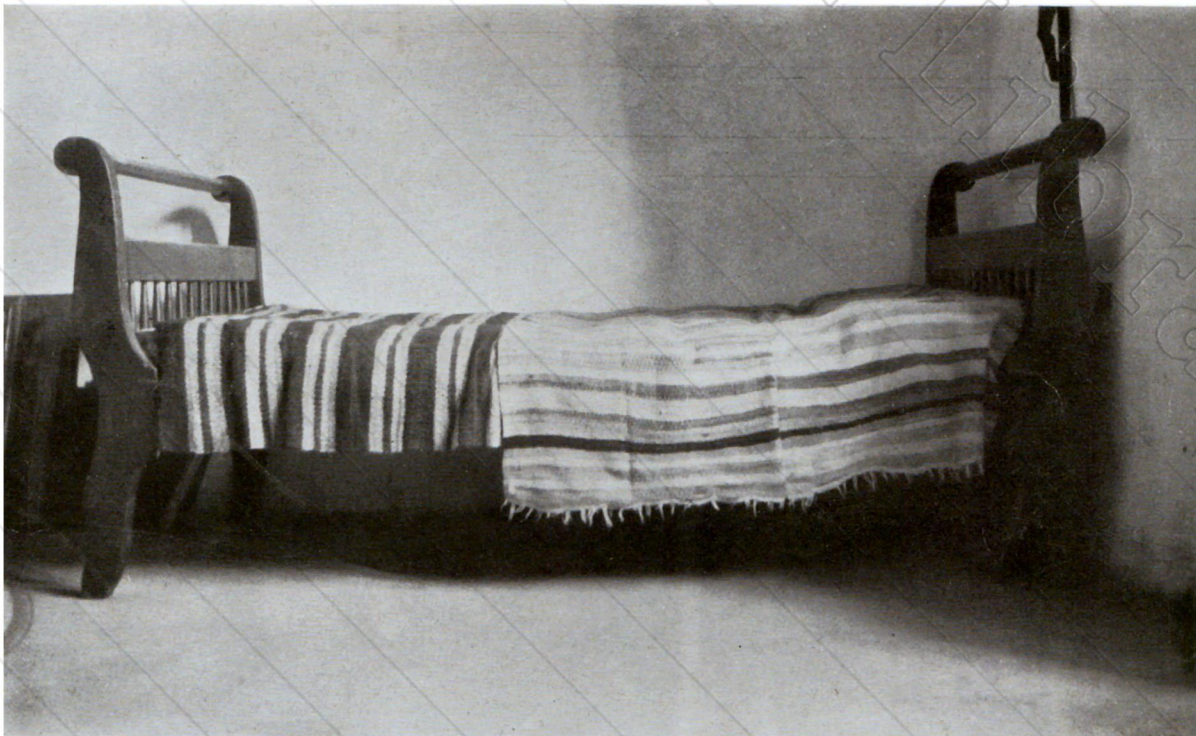

Day Bed — Spanish Influence

Courtesy of Frank G. Applegate

records of those times show that the Indians prospered better during two centuries and a half of Spanish rule than under seventy-five years of American régime."

Going no further afield than the arts, one finds proof enough of this fact. The journey from Old Mexico to New was one of a thousand miles through desert and over mountains. As the means of communication were so bad, the hardships so great, the Spanish brought almost nothing with them. Their love of art was so great, however, that they developed a style of their own; its foundation is laid in pre-baroque Spain, but it is individual enough to be classed as a distinct style and now it represents the second part of our colonial heritage; the one of the Atlantic States based on English art and the Southwestern based on Spanish. To assist in

producing furniture, mission buildings, and other necessities the Spanish called on the Indians for aid. In the missions there are found all sorts of things that were made by the loving hands of the Indian

disciples. Included amongst these are the delightful Santos figures, gesso paintings of religious subjects, architectural stone and wood work, and also furniture, embroidery, and weavings. Perhaps the whips of taskmasters were able to drive slaves to pile stone on stone in the erection of the pyramids, but knowing the Indian psychology one can hardly believe that any amount of cruelty would have prevailed on them to create original design, that shows Western feeling and was inspired under the tutelage of the Fathers.

As said above, Spanish Colonial is pre-baroque in style. Till recently little was known about it, but through



Courtesy of Emile Bernat

Navajo Blanket — Hopi Influence



Courtesy of Frank G. Applegate

"Gesso" Painted Chest — Spanish Colonial

the earnest efforts of groups like the New Mexico Historical Society, authors like Mary Austen and Frank Applegate, and collectors like Miss Mary Wheelwright, it is coming into its own. Very little has been written on the subject; Mr. Applegate has an essay in the *Southwest Review*, and now he is collaborating with Miss Mary Austen on a book that will deal with this art period. The style is rugged in character, simple in line, and pleasing in color and design. The paucity of materials and tools to work with is evidenced, but one must admire these Spanish settlers for their achievements. The style is very decorative and carries that open quality so fitting for the Southwestern environment.

There is no great quantity of objects left, and should a collecting fashion come in the supply will soon be exhausted. It is to be hoped that museums will acquire a good deal of it so that there can be a nucleus for study and designing stimulation. One finds chests, carved and gesso-painted, cabinets with turned wood grilles that are charming in conception, Santos figures—naïve in line and delightful for marionette religious plays, embroideries worked on wool in bold design, glowing colors and with quaint Indian figures and animal studies interspersed. There are also gesso-painted panels on wood with religious scenes as subjects. The painting technique and the

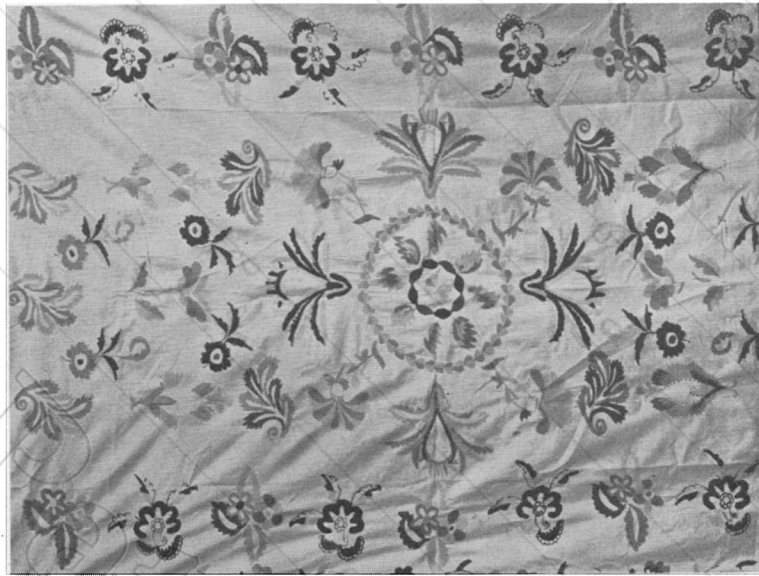

Courtesy of Frank G. Applegate

Colcha. Embroidered on heavy cotton with colored wools. Vegetable dye

compositions are not of a high order; the pictures look bizarre and crude beside the great schools of painting, yet in the fervor of religious spirit and the charm of decoration they rank as fine works of art. There also remain bits of stone work like corbels from churches, and crude metal work like sconces and mirror frames.

Not only are these art relics of value to the Southwest, but also to the rest of the United States. The fact that they represent one step in our art progress is of importance, and also we can gain inspiration for modern work. The

textiles found in pre-Inca tombs have spurred both French and American designers into the creation of gorgeous fabrics for modern use; certainly Spanish Colonial is closer to us and can offer more. Lately we have seen a fad for Spanish and for French Provençal, both are in line with the desire for the quaint and the more homelike. Spanish Colonial reaches us with the same tendency towards simplicity, and it is to be hoped that it will be utilized in the development of our arts; necessary adaptations being made to fit it in our present civilization.

The illustrations in this article will give the reader some idea of the scope of Spanish Colonial; in a later article there will be a more detailed discussion of the period and its products.

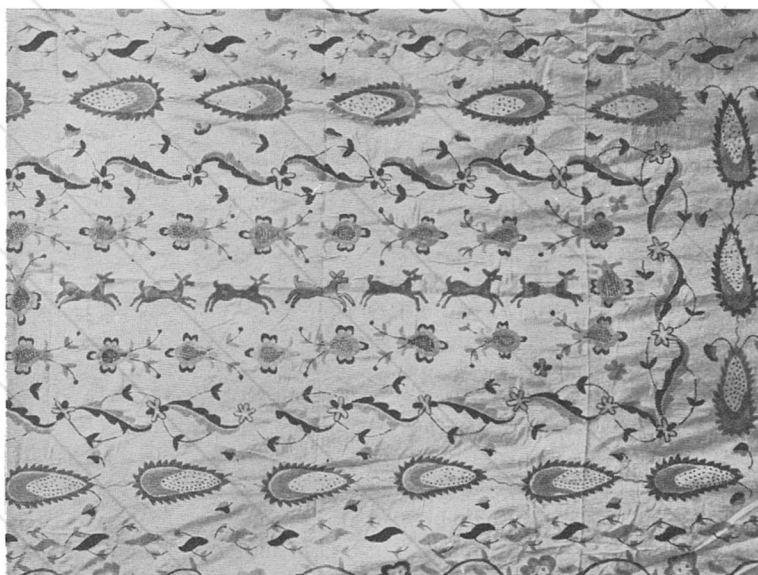

Courtesy of Frank G. Applegate

Colcha. Colored wool embroidery

Hand Made Book Ends

FROM THE MODERN METAL WORKS

ATTRACTIVE book ends like those illustrated (No. 1) are quite easily made by the craftsman and form durable and pleasing gifts. They can be made of any sheet metal which is soft enough to be cut easily and be bent at right angles without breaking. Care should be taken, however, to select the metal best adapted to your design, to the tools at hand, and to the finish desired.

Bronze, brass, steel, and aluminum are all good, but require different handling and finishing. The metal must be stiff enough to support the books without bending, but of course the harder it is the more difficult it is to work, so that a fairly soft metal is best for hand forming.

The book ends shown are made of "Duralumin," an aluminum alloy used in the construction of aircraft, and is nearly as strong as steel and as light as aluminum. It takes a fine polish and is very resistant to corrosion, especially if the surface is given a coat of some good lacquer. It dents quite easily, however, so that care must be used in clamping it in the vise, and it is rather difficult to straighten it by hammering without the hammer marks showing. It is best, anyway, to select a good flat piece of metal for your work.

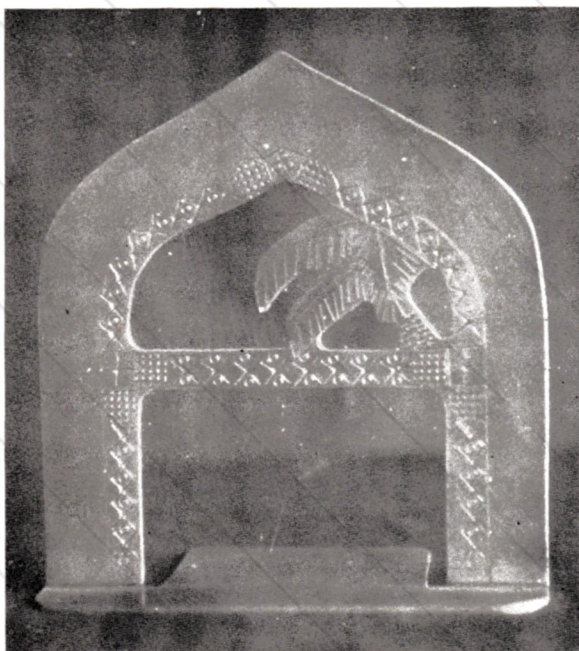

Figure 1

The material and tools needed for making the book ends illustrated are as follows:

One piece "Duralumin," 5" wide by 12" long and $\frac{1}{16}$ " thick.

Cold chisel $\frac{3}{8}$ " wide.

Tin snips.

Hammer.

Hand drill or punch.

Nail set (with countersunk point, which makes the small circle in this design).

Hack saw.

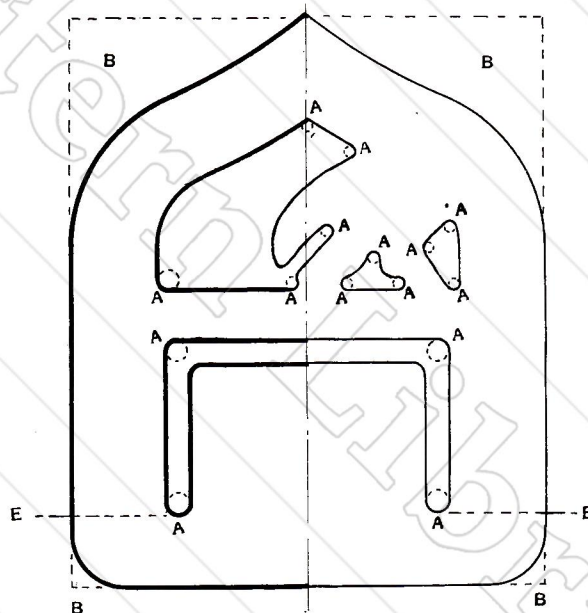

Figure 2

Three files (round, half round and flat, medium smooth).

Emery cloth and crocus cloth (fine grade).

Figuring dies. (See below.)

Small bench vise or "C" clamps.

Flat iron plate or marble slab or table top.

Small anvil or heavy piece of iron on which to cut when using chisel.

The figuring dies of some patterns such as are used in wood-carving may be obtained from dealers in these tools, but you can make very good ones yourself by drilling and filing the end of a piece of $\frac{1}{4}$ " drill rod or tool steel. It will need redressing occasionally, however, unless you temper it, which

can be easily done by slowly heating in a gas flame to a very dull red and then quenching in hot water or oil.

First draw half of the pattern or outline desired on heavy paper as shown by the heavy lines in Illustration No. 2. Cut this out carefully with shears or knife, fold on the center line and mark out the other half so that both sides will be symmetrical. Draw in the palm tree and cut out the other half of the pattern.

If your finished work is to have a polished or "brushed" surface you should do the major part of it now, as it is much easier to do it before the metal is cut out. If your metal has a smooth surface a very little rubbing with the crocus cloth will put

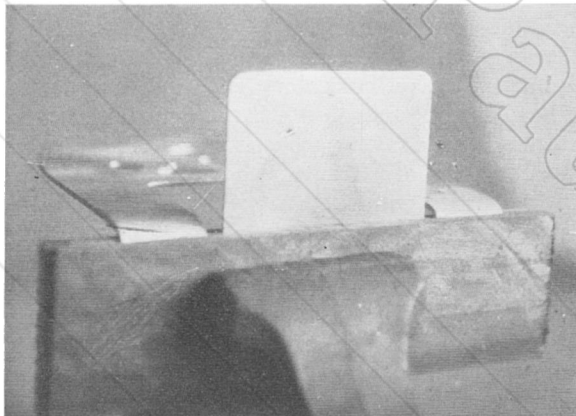

Figure 3

it in good condition. If rough, considerable work with the emery cloth will be needed before the crocus cloth will show any results. A flat hard wood block about $7/8$ " by 3" by 5" to fold the cloth over will be found handy. An attractive and easy finish is made by first getting a good surface on the metal and then going over it lightly in all directions (crossways and in circles) with a piece of rather coarse emery cloth held tightly over the wood block mentioned above. This gives a beautiful "brushed" silver effect to the metal which is very pretty when combined with colored lacquers. This "brushing," however, should be done after the design has been cut out and just before the last operation of bending. Scratching and striking the surface in all directions with a fine steel wire brush will also give good results on this finish.

Now place the pattern on the metal and mark all outlines plainly with a sharp steel point. (A victrola needle bound tightly in a split wood skewer makes a good tool.) Drill holes at points marked A in Illustration No. 2. If a punch is used for this, a thick piece of lead beneath the work is best, however, a hard piece of wood is fairly satisfactory. If the holes are punched some hammering will be

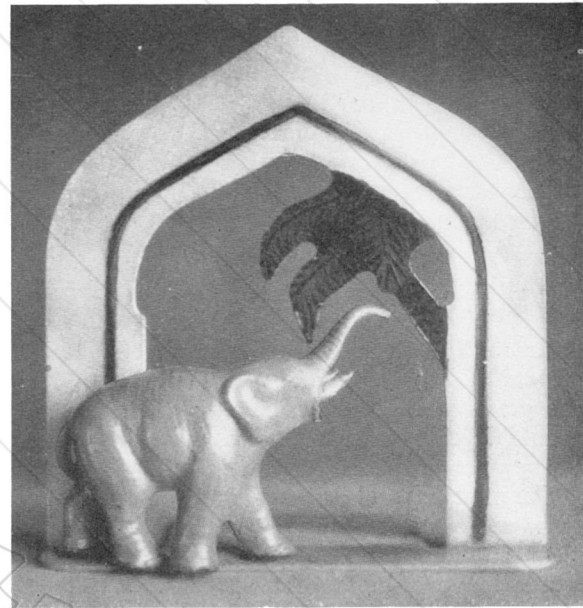

Figure 4

necessary to get the edges flat again, so it is best to use a drill if possible.

Cut out the interior outlines with the punch, chisel, and saw, and finish all edges smooth with the files. Make holes first to insert the hack saw and saw out all places possible. Too much chiseling distorts the metal. Use a soft wood or leather pad in vise jaws or under clamp to protect the surface of the metal. The work may be clamped to a table top when sawing or filing if you have no vise. Leave corners marked "B" until last, as they can be cut off quite easily with the snips and can be used as clamping spots to prevent marring the finished surface.

The design is now stamped with the figuring dies, nail set and chisel, the guide lines being made with a lead pencil as you progress. These may be easily rubbed off or corrected. The sharp pointed tool used in outlining may be used if you desire, as it will not rub off, but great care should be taken, as a slip will leave a deep scratch which is very difficult to remove; especially if the work is polished.

During the figuring you will find that the metal will begin to cup up in places, especially if you make the impressions very deep, and it will be necessary to bend it the opposite way with the hands until this is taken out and the metal lies flat. Sometimes it can be done by tapping it with a hammer over a hollow in a block of hard wood. Use leather or a soft wood block under the hammer to prevent marring the surface. Special care should be used on aluminum and soft brass or every blow will leave a mark.

It is best to wait until the design is all stamped

(Continued on page 45)

This Modernism

BY ROBERT F. HEARTZ

WITH decorations and fabrics going modern, it is time that we seriously turn our thoughts to modernistic designs in hand-weaving. The Colonial weaves have their place in our craft, and it should not be usurped but, with the great changes in design and decoration, we should develop or readapt a class of weaves to meet the new requirements.

The museums and department stores of our large cities are continually arranging exhibits and displays to keep the public informed of the new trends in design. Magazines and newspapers are filled with articles on Modernistic Art; also, they are running numerous advertisements in the modern manner particularly those having to do with the modern wares. Theatres, moving pictures

and the newer apartment and office buildings all show the influence of the new principles of design. It is from all of these various sources that we can draw our ideas and inspirations for our adventures in this new field.

The modern designer depends very much upon arcs and angles, discs, contrast and shadow effects and overlapping plain surfaces to express his reactions and inspirations, yet much of the modern design is quite simple and, sometimes, the simplest is most effective. For colors he depends more upon a few, full, strong colors, than upon the numerous soft and graded color schemes of times past. With the exception of white, which is in little use, most of the other colors are most freely used. Black is in almost constant demand to accentuate and

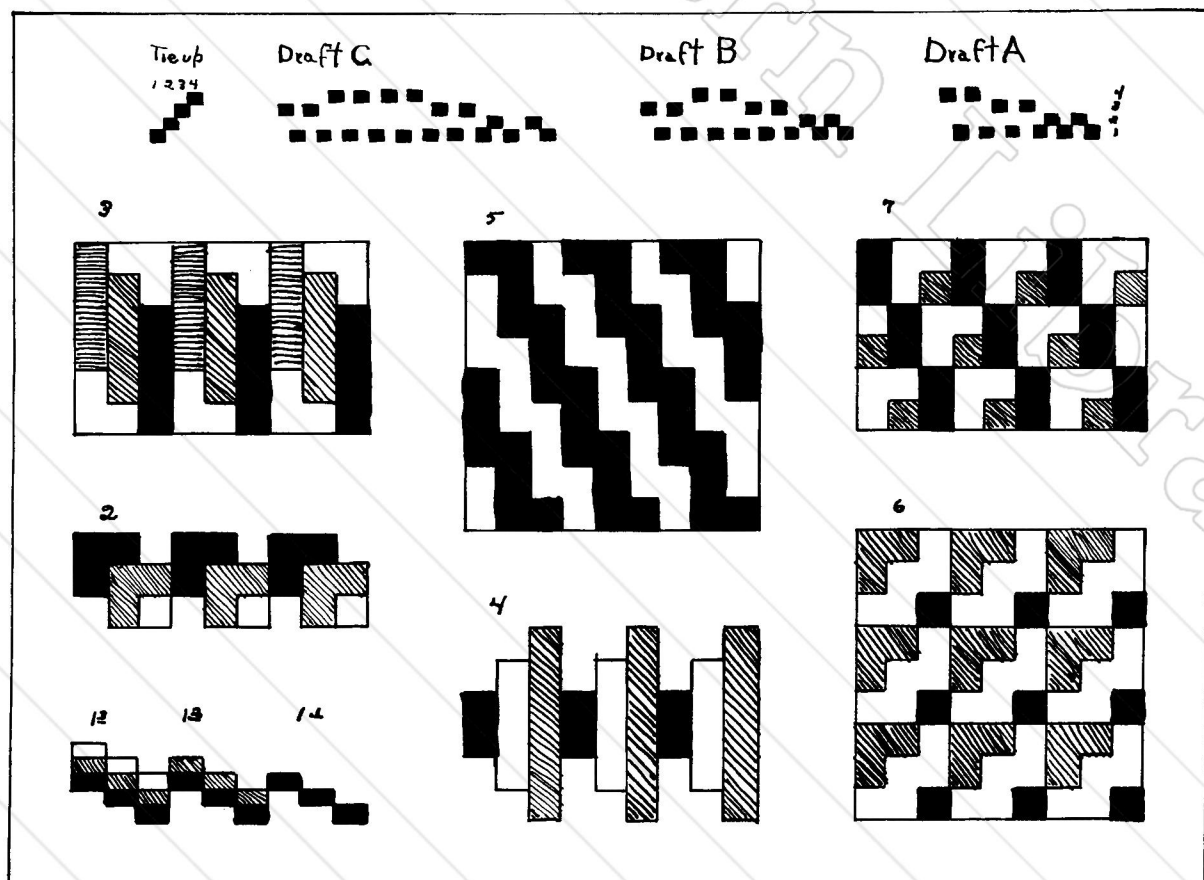

Drafts for Bronson Weave in Modernistic Effects

Robert F. Heartz

bring out contrast and shadows and also to bring out more sharply the other colors of the design. Taupe and gray, shades of brown and orange and the shades of cream and yellow are also in much demand with greens, blues and reds used next in the order in which they are here given.

In planning our experiments, it is well to note what projects are most desirable. Pillows, drapes, wall coverings and wall hangings and, also, rugs are all very good. With the highly polished surfaces, table scarfs are not much in use in an interior that is wholly modern, but they do give an effective touch in a room to which one desires to add just a modernistic touch, to balance a new lamp or other fixture. Modern table linen and scarfs are very much in vogue for the dining room, especially colored sets of linen.

There are several classes of weaves that we have depended upon for our design effects in all our weaving, and some of these types adapt themselves very readily to modern demands, so we will review them here.

Tapestry, embroidery, stick weaving; any of the two-harness pattern weaves are good, because any design that can be developed on graph paper can be worked out in the woven piece. Of these weaves, nothing further will be said.

Four-harness overshots and weaves on opposites are more or less balanced weaves, and, because certain combinations of treadling usually follow in regular order, are not readily adaptable for modernistic effects.

There is a weave used to a certain extent in this country, called "The Bronson Weave," that is very good for small, all-over patterns and border arrangements, and it is with this weave that we are going to work.

Double-face, or summer and winter weaving, is also very good and will be given consideration later.

Damask and double weaving are most suitable but, because of the number of harness frames required, are out of the question for most weavers, so they will not be further considered.

With the use of a dobby or jacquard attachment, any design that can be developed on graph paper can be woven but, as we are limiting ourselves to 4-6 harness weaves, they are also out of the question.

THE BRONSON WEAVE

This weave is used in the Scandinavian countries and, also, a similar weave is found in this country, coming down from an earlier period. It has been described by an old weaver, called Bronson, and is so named for him. The manner in which it is developed makes it especially desirable for our present problems. It is adaptable to small border and pattern designs, laid out in vertical and horizontal lines. The different stripes and blocks can also be carried out in different colors.

Referring to Draft A, all of the odd threads (1, 3, 5, 7, etc.) are drawn in the heddles of the first harness or ground frame. All of the even numbered threads (2, 4, 6, 8, etc.) are distributed on the three remaining or pattern frames. The blocks in this project are limited to four threads (1, 2, 1, 2; 1, 3, 1, 3; 1, 4, 1, 4, etc.), but they can be increased to 6, 8 or 10 threads. This is

not particularly desirable, except in very fine work. Draft A is what is called a straight draft, as the frames are drawn in regular order, 2, 3, 4. The straight tie-up is also used. The sheds for tabby, or plain weaving, are: treadle 1 and treadles 2, 3, 4 together.

In pattern weaving, the first treadle is always down and, also, by lowering one or two of the pattern frames, the pattern thread is allowed to flood over the warp. Where the pattern weft is tied down by the warp, a half-tone effect is the result. For this type of weaving where contrast is the result, this is undesirable. To overcome this half tone, the pattern frames which were lowered are raised, and those pattern frames which were raised are lowered and another pattern thread is inserted. There should be no tabby weft between these pattern wefts, so when the shed is beaten up a continuous line of pattern weft crosses the fabric. The pattern weft should be soft and fluffy so that, when beaten up, it spreads out and covers the warp threads. Different colors should be used and blocks of different colors can be built up. The pattern frames can be used single, or in pairs; thus, blocks of different shapes and sizes can be obtained, as well as blocks of different colors. Illustrations 1 through 7 are a few of the designs possible on the draft given at A, and with the straight tie-up.

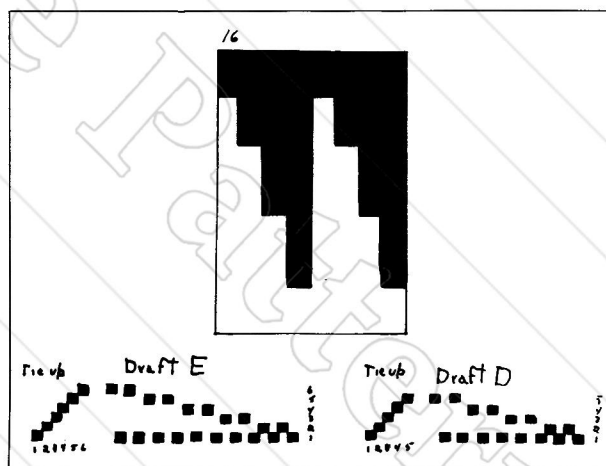

Drafts for Bronson Weave in Modernistic Effects

Illustration 1 (1) is the simplest pattern that can be woven. It was planned for a towel to be woven on a fine cotton warp (about a 20/2) set 24 or 30 ends per inch. The weft, which is white, can be of linen, lustrone or fine cotton. Fabri, weaving special, or lustrone can be used for the pattern weft.

Treadle about six inches with the tabby weft, using treadle 1 and treadles 2, 3, 4. This is for a hem. Two shuttles of pattern weft are required for the border, one of green fabri and one of white fabri to match the ground. It is necessary to use the white fabri to cover up the half-tone effect, produced by the green fabri. The pattern treadling is: Treadles 1-2 green fabri; 1-3-4 white fabri; 1 tabby weft between each complete pattern shed; repeat. Treadles 1-3 g. f.; treadles 1-2-4 w. f.; tabby; repeat. Treadles 1-4 g. f.; treadles 1-2-3 w. f.; tabby; repeat.

Illustration 1 (2) is an elaboration of 1 (1), using two colors. Treadled: 1-2 g. f.; 1-3-4 w. f.; tabby; repeat. 1-2 orange fabri; 1-3 g. f.; 1-4 w. f.; tabby; repeat. 1-2 w. f.; 1-3 o. f.; 1-4 g. f.; tabby; repeat. 1-2-3 w. f.; 1-4 o. f.; tabby; repeat.

Illustration 1 (3) is still a further variation of 1 (1), using one more color.

Treadled: 1-2 g. f.; 1-3-4 w. f.; tabby; repeat. 1-2 o. f.; 1-3 g. f.; 1-4 w. f.; tabby; repeat. 1-2 yellow fabri; 1-3 o. f.; 1-4 g. f.; tabby; repeat. 1-2 w. f.; 1-3 y. f.; 1-4 o. f.; tabby; repeat. 1-2-3 w. f.; 1-4 y. f.; tabby; repeat.

Weave about a yard of plain or tabby and reverse the border for opposite end. Weave six more inches for hem and the towel is complete.

Illustration 2 shows how the blocks may be combined for a different pattern. The design can be used as a pattern, or all-over pattern. For an all-over pattern, it should be worked in coarser materials. It was planned for a heavier warp; 16/3 Egyptian or 10/2 mercerized; set 15 to 20 ends per inch. The tabby weft may be of heavy cotton or linen with the pattern weft of Shetland or Lustrone.

Treadling for border on white ground: 1-2 orange Shetland; 1-3 brown Shetland; 1-4 white Shetland; tabby; repeat 4 X; 1-2-3 brown s.; 1-4 black s.; tabby; repeat 4 X; 1-2 w. s.; 1-3-4 black s.; tabby;

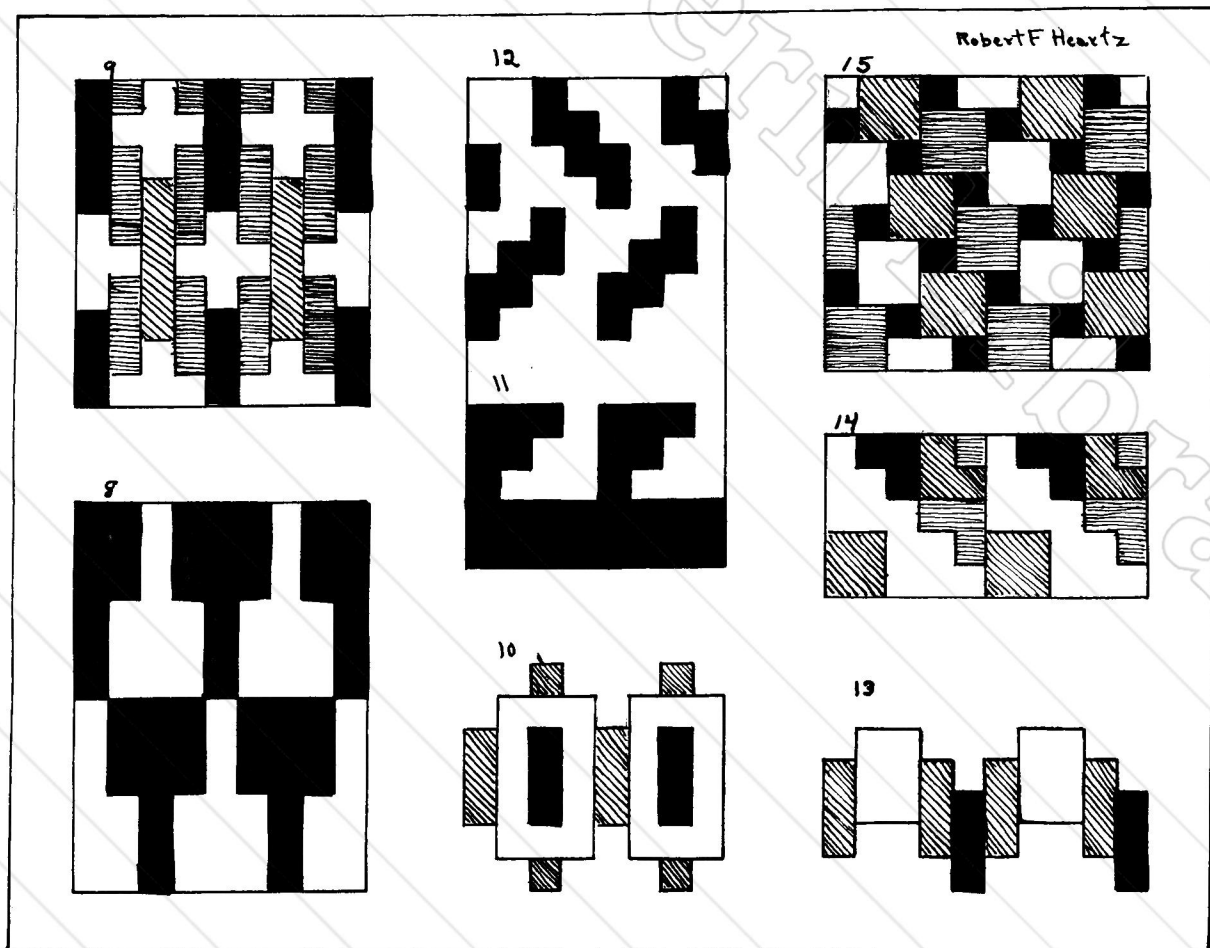

Drafts for Bronson Weave in Modernistic Effects

repeat 4 X. Reverse for opposite border. When design is used for an all-over pattern, the tabby weft can be the same material as the warp or slightly lighter in weight, as it is not visible and allows the woven weft to be beaten more closely together.

Illustration 3 is a striped border and may be executed in the fine or coarse warp. Treadling: 1-2 blue fabri; 1-3-4 w. f., to match tabby; tabby; repeat 4 X; 1-2 b. f.; 1-3 g. f.; 1-4 w. f.; tabby; repeat 4 X; 1-2 b. f.; 1-3 g. f.; 1-4 y. f.; tabby; repeat 8 or 10 X; 1-2 w. f.; 1-3 g. f.; 1-4 y. f.; tabby; repeat 4 X; 1-2-3 w. f.; 1-4 y. f.; tabby; repeat 4 X. Reverse for opposite border.

Illustration 4 — Border: Treadling: 1-2 o. f.; 1-3-4 w. f.; tabby; repeat 4 X; 1-2 o. f.; 1-3 tan f.; 1-4 w. f.; tabby; repeat 4 X; 1-2 o. f.; 1-3 tan f.; 1-4 brown f.; tabby; repeat 8 X; 1-2 o. f.; 1-3 plus f.; 1-4 w. f.; tabby; repeat 4 X; 1-2 o. f.; 1-3-4 w. f.; tabby; repeat 4 X.

Illustration 5 is an all-over pattern, known as a "Corkscrew Twill." Treadling: 1-2-3 blue Shetland; 1-4 tan s.; tabby; repeat 4 X; 1-3 b. s.; 1-2-4 t. s.; tabby; repeat 4 X; 1-3-4 b. s.; 1-2 t. s.; tabby; repeat 4 X; 1-4 b. s.; 1-2-3 t. s.; tabby; repeat 4 X; 1-2-4 b. s.; 1-3 t. s.; tabby; repeat 4 X; 1-2 b. s.; 1-3-4 t. s.; tabby; repeat 4 X. Repeat from beginning. Suitable for pillow or wall piece. Could be used for drapes, but, because the back is plain, it might be desirable to line them.

Illustration 6 — Another all-over pattern. Is suitable for drapes, pillows, or wall hanging. No. 2 might be adapted for a border. Treadling: 1-2 brown Lustro; 1-3-4 orange l.; tabby; repeat 4 X; 1-2-3 o. l.; 1-4 blue l.; tabby; repeat 4 X; 1-2 o. l.; 1-3-4 blue l.; tabby; repeat 4 X.

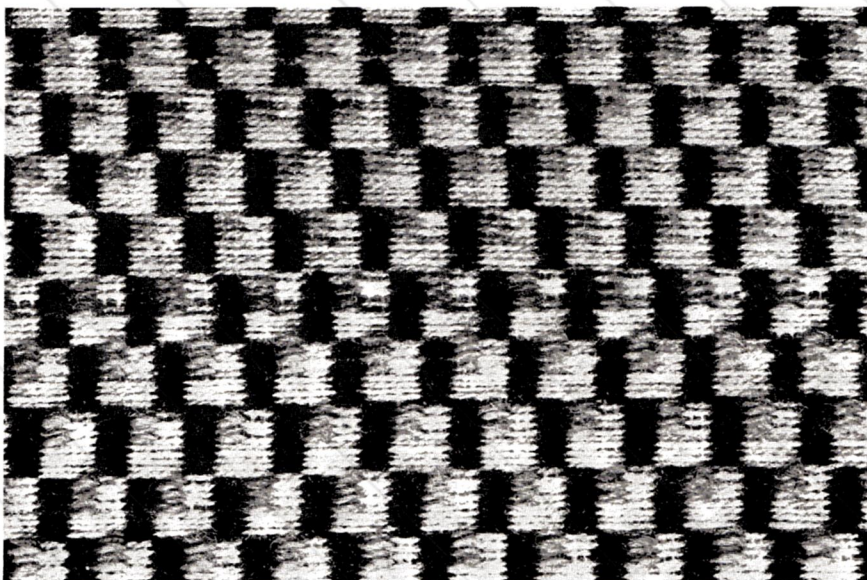

Texture of Bronson Weave in Modernistic Effects

This might also be woven, using brown and orange Shetland, trying a blue Lustro, or No. 5 Perle cotton, resulting in a silky figure on a soft wool ground.

Illustration 7 is another all-over pattern. This also can be combined with No. 2 for a border. Treadled: 1-2 black Shetland; 1-3 red s.; 1-4 yellow s.; tabby; repeat 4 X; 1-2 b. s.; 1-3-4 y. s.; tabby; repeat 4 X. 1-2 y. s.; 1-3 b. s.; 1-4 r. s.; tabby; repeat 4 X; 1-2-4 y. s.; 1-3 b. s.; tabby; repeat 4 X; 1-2 r. s.; 1-3 y. s.; 1-4 b. s.; tabby; repeat 4 X; 1-2-3 y. s.; 1-4 b. s.; tabby; repeat 4 X. Repeat from beginning.

Some of the smaller all-over patterns could be woven on a still coarser warp, set 10 to 15 ends to the inch, with a coarser tabby weft and a pattern weft of Zephyr, Lustrex or Germantown. The long floats of pattern weft renders this class of weaves unsuitable for rugs.

Draft B is a point draw being drawn 2 3 4 3 in the pattern frames. Illustrations: 8, 9 and 10 show three of the designs possible with this draft. Many of the treadling drafts of the preceding and following groups may be interchanged for use with this draft and the treadling drafts of this group may be used with other drafts.

The treadling for Illustration 8 is: 1-2-3 brown wool; 1-4 orange silk; tabby; repeat 12 X; 1-3-4 orange silk; 1-2 brown wool; tabby; repeat 12 X; 1-3-4 brown wool; 1-2 orange silk; tabby; repeat 12 X; 1-2-3 orange silk; 1-4 brown wool; tabby; repeat 12 X.

Illustration 9: 1-2 tan wool; 1-3-4 black wool; tabby; repeat 4 X; 1-2 tan wool; 1-3 gray wool; 1-4 black wool; tabby; repeat 4 X; 1-2 tan; 1-3 gray; 1-4 green wool; tabby; repeat 4 X. 1-2 black; 1-3 gray; 1-4 green; tabby; repeat 4 X; 1-2-3 black; 1-4 green; tabby; repeat 4 X. 1-2 black; 1-3 gray; 1-4 green; tabby; repeat 4 X; 1-2 tan; 1-3 gray; 1-4 green; tabby; repeat 4 X; 1-2 tan; 1-3 gray; 1-4 black; tabby; repeat 4 X.

Illustration 10 is a border design, though it can be adapted for an all-over design. Designed for orange, bright green and gray on a black ground. Treadled: 1-3-4 black wool; 1-2 orange wool; tabby; repeat 4 X; 1-2-3 gray; 1-4 black; tabby; repeat 4 X; 1-2 green wool; 1-3 gray; 1-4 orange;

tabby; repeat 4 X; 1-2-3 gray; 1-4 black; tabby, repeat 4 X; 1-3-4 black; 1-2 green; tabby; repeat 4 X.

The draft given is an irregular point draft; that is, the blocks are woven unequal in size. One example of this draft is shown here, that one may see still further possible combinations. The irregular blocks may be used in the straight draft and with any combination of harnesses.

An illustration is given at 1-3. It is treadled: 1-2 russet wool; 1-3-4 white ground wool; tabby; repeat 4 X; 1-2 russet; 1-3 orange wool; 1-4 white; tabby; repeat 4 X; 1-2 russet; 1-3 orange; 1-4 gray wool; tabby; repeat 4 X; 1-2 white; 1-3 orange; 1-4 gray; tabby; repeat 4 X; 1-2-3 white; 1-4 gray; tabby; repeat 4 X.

One pattern arrangement is given for a straight draw on five-harness. The draft and tie-up is given at Draft D.

Illustrations 11 and 12 show a border and pattern that may be used together, or each may be used separately.

Treadled: 1-2 blue; 1-3-4-5 blue; tabby; 1-3 blue; 1-2-4-5; tabby; 1-4 blue; 1-2-3-5 blue; tabby; 1-5 blue; 1-2-3-4 blue; tabby; repeat from beginning, until desired width is obtained. Treadling in this order completely covers the ground evenly without any ridges or lines showing. Continuing: 1-2-3-4 gray; 1-5 blue; tabby; repeat 4 X; 1-2-3 gray; 1-4-5 blue; tabby; repeat 4 X; 1-2 gray; 1-3-4-5 blue; tabby; repeat 4 X.

1-2 gray; 1-3-4-5 gray; tabby; 1-3 gray; 1-2-4-5 gray; tabby; 1-4 gray; 1-2-3-5 gray; tabby; 1-5 gray; 1-2-3-4 gray; tabby; repeat gray, until desired width is woven.

1-5 blue; 1-2-3-4 gray; tabby; repeat 4 X; 1-4-5 blue; 1-2-3 gray; tabby; repeat 4 X; 1-3-4 blue; 1-2-5 gray; tabby; repeat 4 X; 1-3 blue; 1-2-4-5 gray; tabby; repeat 4 X; 1-5 blue; 1-2-3-4 gray; tabby; repeat 4 X; 1-2-5 blue; 1-3-4 gray; tabby; repeat 4 X; 1-2-3 blue; 1-4-5 gray; tabby; repeat 4 X; 1-3 blue; 1-2-4-5 gray; tabby; repeat 4 X.

In Illustration 16 is another five-harness design. It can be used to shade from a dark border to a light center, or a different color can be introduced with each frame, as it is picked up.

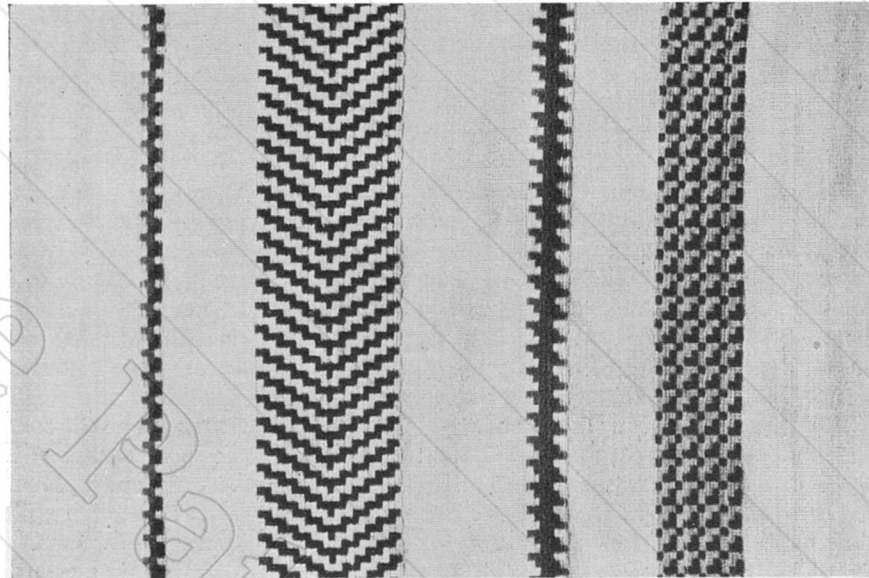

Examples of Bronson Weave in Modernistic Effects

Treadling: 1-2 brown; 1-3-4-5 brown; tabby; 1-3 brown; 1-2-4-5 brown; tabby; 1-4 brown; 1-2-3-5 brown; tabby; 1-5 brown; 1-2-3-4 brown; tabby; repeat from beginning about 8 X, until proper width; 1-2 orange; 1-3-4-5 brown; tabby; repeat 12 X; 1-2-3 orange; 1-4-5 brown; tabby; repeat 10 X; 1-2-3-4 orange; 1-5 brown; tabby; repeat 8 X.

1-2 orange; 1-3-4-5 orange; tabby; 1-3 orange; 1-2-4-5 orange; tabby; 1-4 orange; 1-2-3-5 orange; tabby; 1-5 orange; 1-2-3-4 orange; tabby; weave center and reverse pattern treadling at the other end.

Illustrations 14 and 15 are obtained on the six-harness straight draw, which is shown in Draft E.

No. 14 may be used as a separate border, or it may be used with the all-over pattern, shown in Illustration 15.

Treadling for border: 1-2-3-4 orange; 1-5-6 blue; tabby; repeat 4 X; 1-2 green; 1-3-4 orange; 1-5-6 blue; tabby; repeat 4 X; 1-2-3 green; 1-4-5-6 orange; tabby; repeat 4 X; 1-2-3 blue; 1-4 brown; 1-5-6 orange; tabby; repeat 4 X; 1-2 green; 1-3 blue; 1-4-5 brown; 1-6 orange; tabby; repeat 4 X.

Treadling for pattern: 1-2 brown; 1-3-4 orange; 1-5-6 green; tabby; repeat 4 X; 1-2-3 blue; 1-4 brown; 1-5-6 green; tabby; repeat 4 X; 1-2-3 blue; 1-4-5 orange; 1-6 brown; tabby; repeat 4 X; 1-2 green; 1-3 brown; 1-4-5 orange; 1-6 green; tabby; repeat 4 X; 1-2 green; 1-3-4 blue; 1-5 brown; 1-6 green; tabby; repeat 4 X; 1-2 brown; 1-3-4 blue; 1-5-6 orange; tabby; repeat 4 X; 1-2-3 green; 1-4 brown; 1-5-6 orange; tabby; repeat 4 X; 1-2-3 green; 1-4-5 blue; 1-6 brown; tabby; repeat 4 X; 1-2 orange; 1-3 brown; 1-4-5 blue; 1-6

(Continued on page 46)

A Craftsman Influences a City

BY PAULINE G. SCHINDLER

THE recent development in Europe of modern architecture and the industrial arts owes much to the existence of the Bauhaus, in Dessau, Germany, which for some reason or other has become a focal point of practical-aesthetic experiment. The adventures of the Bauhaus with metal furniture, with lighting devices, with architectural structure which has stepped out of all traditional pattern, begin to be known over all the world, and have their echo even with us.

In the city of San Francisco, facing a bit of green park flanked on one side by Chinatown and on the other by the maze of the business district and the department stores, there is similarly a little oasis of creative, imaginative activity, — the studio workshop of Rudolph Schaeffer.

Here, at any hour of any day, you come upon students and craftsmen working, independently and experimentally, with form and color in all imaginable media. Instead of laboring their way through historic periods of art, they are playing with the

materials they find in the world about them, — metal, wire, cloth, glass, or any new thing. Their attitude of experiment has about it some of the freshness and wonder of a child exploring its universe.

Such soil nourishes fruitful seed. The manipulative play with forms and colors, simultaneously with the setting and meeting of aesthetic problems, opens in one direction new paths in the fine arts; and in the other, it inevitably deals in a practical way with the things of life.

This stimulus which the workshop of Schaeffer has given to play with things, from door-handles to textiles, or the arranging of bookshelves in relation to a wall-space, or to play with color on wood, now to an astonishing degree begins to influence the culture of its

city. Eventually it must also influence industrial design in multiple mass production.

This is a studio of craftsmen ready to deal with any material; yet the bases of principle from which their work springs give it such character that the

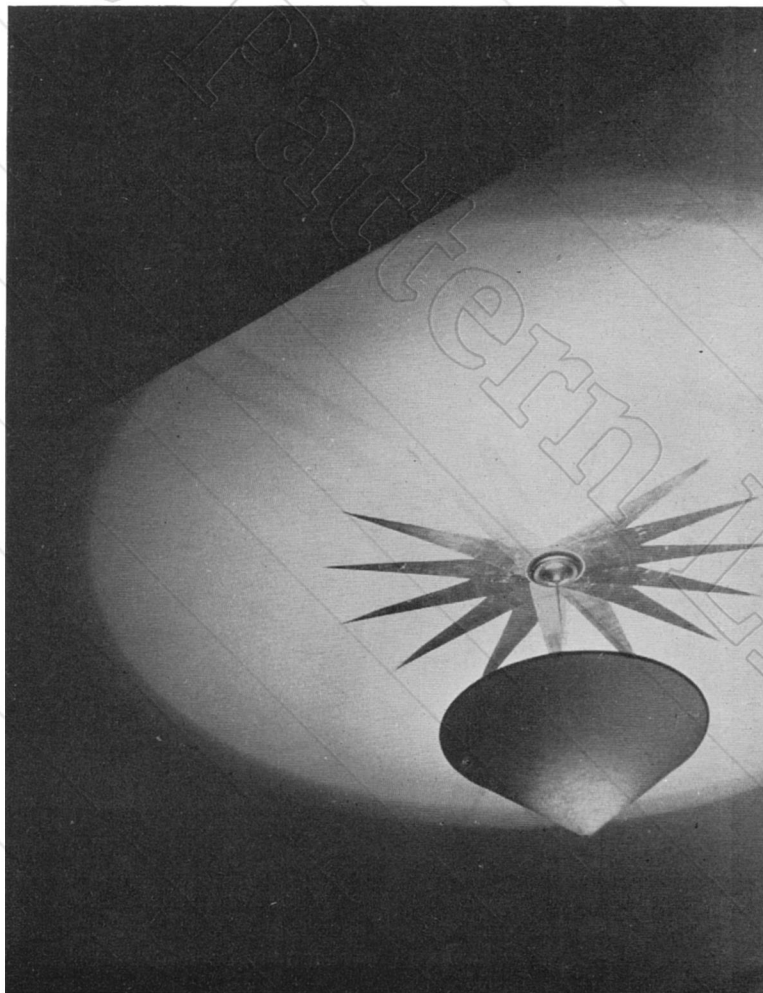

A Ceiling Light Designed and Made by Rudolph Schaeffer. The cone is of heavy stencil board, whose form gives a wide circle of soft light reflected from the ceiling. A bit of play with design is added in the silver paper strips applied to the ceiling

products of the studio are recognizable anywhere as definitely of Schaeffer stamp. The color relationships, the dynamic rhythms are characteristic.

Because he is a craftsman who has not limited himself to one material, but deals with all, Schaeffer

worship, because of their rarity. For it will have occurred to us at last that a kitchen, and every item in it provide opportunity by way of form and line and color, for the creation of a sufficient and total beauty in itself.



Rudolph Schaeffer re-designed the interior of the Western Women's Club in San Francisco in order to provide a consistent and expressive background for the recent exhibition of modern decorative arts he assembled there

has become concerned, as an artist, with practical aesthetic organization. Walk past the windows of a San Francisco department store; an arrangement by Schaeffer arrests you. Or here are lighting fixtures showing the same fine simplification of forms. In the center of town you come upon a cafeteria which, from the first stairway treads to the last tiniest detail of price labels and the selection of flowers, even to the color-choices in desserts, carries the unmistakable stamp and the consistent unity of design by Schaeffer.

A shop window, a cafeteria, even a plumbing fixture, may be organized into a work of art. Eventually we shall no longer find it necessary to set our objects of beauty in museums and shrines of

To create a single lovely object in the world is a contribution to life. But to organize items of beauty into totalities of arrangement is to augment this by what may be called another dimension of beauty. A room so designed shows for the proportions and the spaces in which objects are composed as great a respect as for the objects themselves, and attains an organic unity, a serenity, which rooms as mere assemblages of objects seldom possess.

Some months ago the Western Women's Club of San Francisco asked Schaeffer to organize for them an exhibition of modern interior arts. Not only did he gather together the works of craftsmen, architects, textile designers, sculptors, and potters,

creating in the modern spirit; but he was given full freedom with the exhibition rooms themselves, and was thus able to carry out consistently the design of the thing as a whole, even to such details as lighting fixtures, which were specially built. So consistent and adequate a carrying out of this exhibition made it an outstanding event of the year, so great was its impact on those who saw it. It was not merely an event which filled the calendar space for a month, but was deeply experienced and remembered, and has since strongly influenced the work of artists on the Pacific coast.

The artist working in the modern spirit is still a

lonely creator. He is in constant danger of being confused with the charlatan imitators who run "modernism" into the decadence of a style, a fashion, or still worse, a fad. In the hands of the true modern creators now living, the fine arts and architecture, the crafts and the industrial arts, are entering a period of great vitality. But what they are doing needs to be understood. It is therefore important that there be such centers of creative activity as the Schaeffer studio, which as a building, as an atmosphere, and in its many activities, does provide a fine and intelligible expression of the modern spirit.

The History of a Race Is Told by a Modern Craftsman in Wood

BY PAULINE G. SCHINDLER

SCULPTURE and wood carving are closely related arts. A terra-cotta grille above the Students' Union at the University of California in Los Angeles reproduces the design by Peter Krasnow, painter and wood carver, for that building. But for the great ceremonial chest of the Temple Emanuel in San Francisco, this artist has wrought directly in wood itself, carving three panels fronting the architectural structure three feet long and nearly eight in height.

The ceremonial chest is a shrine, an ark of the covenant, made to house the historic treasures of the temple. Its three panels slide open to disclose these symbolic gifts lying upon a background of lacquer red modified by a slight bluish shadow, and illumined by light from hidden sources.

Carven wood is particularly a medium for communicating the sense of richness in history. Cut in grooves of outline upon the flat oaken surface, these carvings of Krasnow retain the silken soft smoothness of the wood enriched by depth-giving

shadow. The beauty of the wood as a living material grained with the record of its own life is finely accented. Upon wood as a thing of history, the carven tale of a great racial history is still further imposed in fitting lines and masses.

A deeply elemental Hebraic feeling pervades the work. The three panels depict symbolically the economic and cultural life of the Jewish people:

Panel A: The builders of Palestine. Eternal forms belonging to no period of time.

Panel B: Science and learning. The new master piercing the veil of matter to search

the ultimate — another step in time's march.

Panel C: The tilling of the soil. Men and women repopulating the earth and bringing to it new beauty of life and living.

The feeling of the work is timeless, elemental, and universal. "A bold and tender craftsman," one of the critics, writing of the chest, has called Krasnow. Strong simple rhythms give the work a dynamic quietness, a serenity like that of the seed in the earth, confident, awaiting its time.

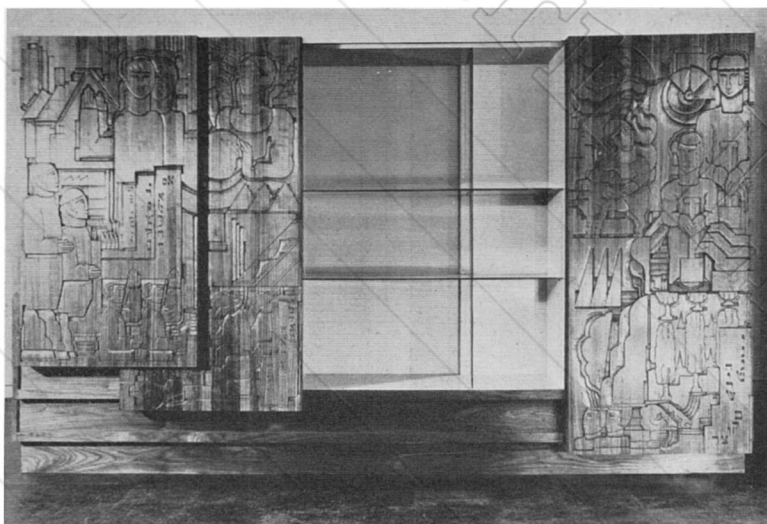

Three sliding panels carved by Peter Krasnow tell symbolically the story of the ancient Hebraic culture. Ceremonial chest in the Temple Emanuel in San Francisco



Point de Toile. Two threads darned up and down, two threads darned backward, and two forward over each mesh of pattern

Filet

BY LOUISE AUSTIN CHRIMES

FILET is the French word for net, but is generally understood to mean the finished lace.

It is not known when netting was first done, but fine nets have been found among Egyptian relics. The making of net is a simple process, and the necessary "tools" are few, inexpensive, and easily obtained. The beauty of netting is in the perfect regularity of the loops and tightness of the knots, also the thread used has much to do with the evenness and durability of the net that the worker makes.

Netting needles and mesh-sticks come in several sizes, and care must be taken in the selection of needle, stick and thread, that they are all of correct size to make a perfect net. Linen threads, of a rather hard twist, are best for net, one that will stand a hard pull on the knot without breaking.

Netting needles are steel, and mesh-sticks are of bone, wood, ivory or steel, flat or round. The size of mesh is determined by the width of the mesh-stick. When making very fine net, a steel knitting needle is used as a mesh-stick, and as the finest



Coarse Net Worked with Heavy Linen Thread. Conventional design copied from an old French piece



The Mounting of the Net in Covered Wire Frame. Shows method of making pattern in linen stitch or Point de Toile

netting needle would be too large to pass easily through the fine mesh, it would be necessary to use a fine darning needle, with as long a thread as could be handled. Netting needles are a kind of shuttle, long and with an eye at each end, and are filled with enough thread, to pass easily through the mesh.

row; the second row of meshes being worked into the first row, and so on, each row knotted into the row before.

When a new thread is needed, join it to the edge with a weaver's knot. Should the thread break in the middle of a row, a new one is added in the usual



(Left) Panel of Fine Linen Thread. Worked entirely in Point de Toile. Designed and executed by the author



(Upper right) Net of Very Fine Thread. Four different stitches used. Copy of section of old piece

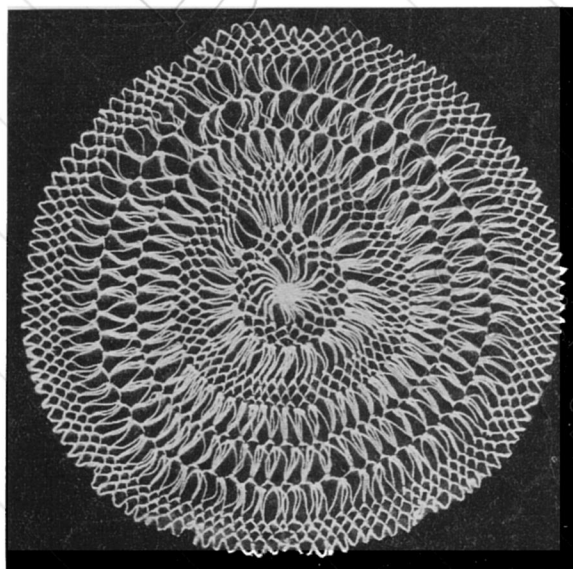

(Lower right) Simple Circular Netting, using two sizes of mesh sticks

To begin the making of the net, a foundation loop is fastened to a heavy cushion, or to anything firm enough to enable the worker to get the right amount of pull on the knots, which must be securely made, or they will slip and make a loose and uneven net. The end of thread in needle is tied to the foundation loop, and the first mesh is made into the same loop. The foundation loop will not be used after the first

way, bringing the weaver's knot close up to knot of last loop, but joining anywhere but at the edge should be avoided if possible.

As the net grows in length, it is best to tie it firmly, near the mesh-stick, and make a loop to hold it to the cushion, as working with a long piece of net, held only by the first foundation loop, would be very awkward to handle, and tend to

make the net loose and uneven. The illustration of the large piece of net shows what is meant by tying close to mesh-stick as work progresses. This piece of net is made of natural shade of carpet thread, five meshes to the inch, and is to be two yards square when finished.

Oblong strips, squares, rectangles, hollow

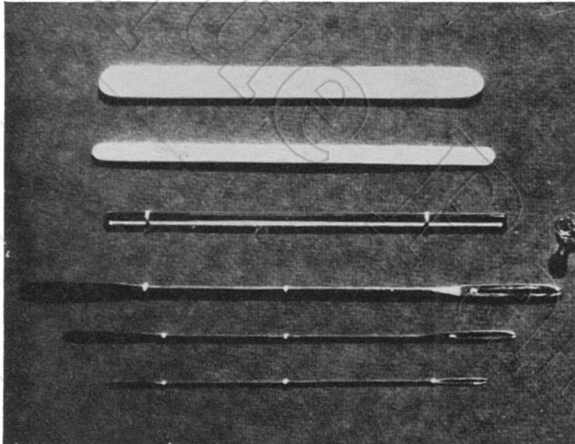

Three Sizes of Netting Needles. Three mesh sticks — round, old love with bevel edge, and type of flat stick procurable today

squares for borders around linen centres are some of the shapes that can be made in netting, also circular pieces, using several sizes of mesh-sticks, and different stitches in the same piece. Net that is later to have a pattern darned into it must be just a plain square mesh net, but many lovely insertions and edgings are made by using different sticks and stitches, and color can be introduced in rows, making delightful trimmings for household linens.

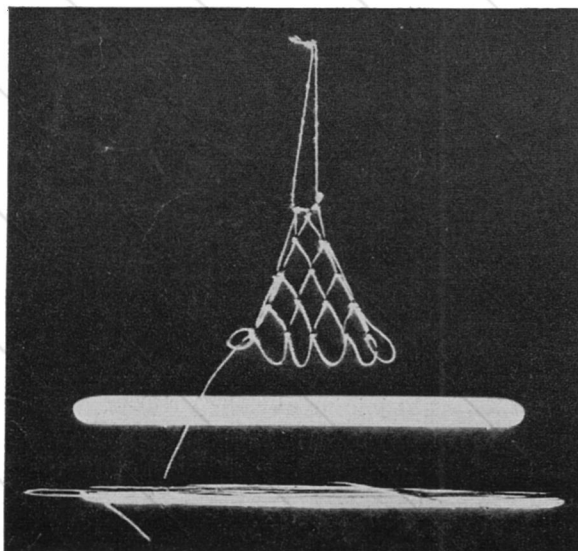

Starting of Net. End of thread tied to loop

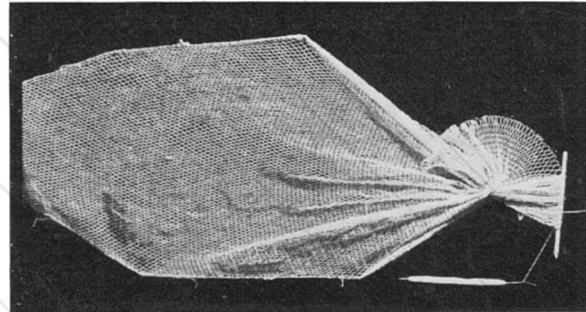

Coarse Net for Large Tablecloth, showing proper way to tie large pieces of net in the making. This method keeps meshes even

Old-time tufted coverlets were usually trimmed with netted fringes, and testers to decorate the canopy tops of old four-poster beds were made with many fancy netting stitches, and charming patterns formed by the tying of little tassels into the net.

For this Colonial netting, knitting cotton is used, with a large netting needle, and various sizes of mesh sticks.

After a piece of net is finished, it has to be stretched in a frame for the pattern to be darned in. These frames are best made of heavy wire, strong

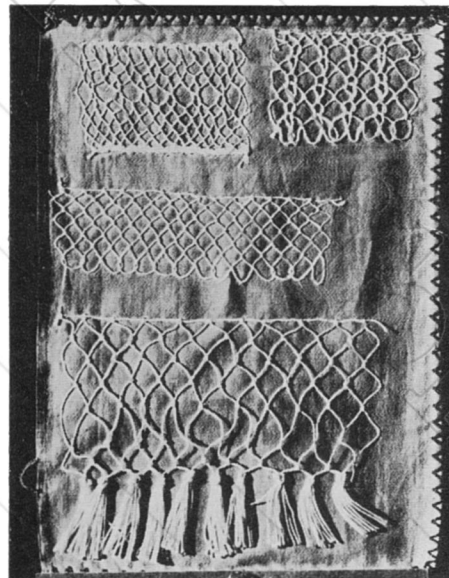

Samples of Net, showing different thread and stitches

enough to allow the net to be tightly stretched upon it without bending out of shape. In large frames, a wire brace, crossing in the centre is necessary. The frame must be covered with a soft narrow tape, binding it firmly and evenly in a slanting direction, and fastened securely when frame is entirely covered. The frame should be

(Continued on page 44)

A Clipping or Filing Case

BY EDITH P. FETTEROLF

FILING CASES are the handiest things! Everybody needs several. Very stunning ones done in the modern spirit can be made by any boy or girl. Grown-ups, too, will find they can make very charming ones with but little trouble. They cost practically nothing when made at home, yet they are very expensive when bought in the novelty shops. Think how useful they are for filing recipes, menus, advertisements, pictures, etc. One can make them any size desired and in any color. One or a set of different sizes would make a most useful and novel gift.

Here is a list of materials you will need to make one:

Two envelopes of good quality, both of the same size.

Two pieces of heavy cardboard, a little larger than the envelopes.

Two strips of plain color material, cotton or linen about two inches wide. This is for the hinge.

Material for covering the case. This may be cotton, linen, cretonne, decorated or plain, or it may be of paper.

Two pieces of tape or ribbon five or six inches long for ties.

Paste, scissors, ruler, pencil and a rag for rubbing down.

The envelopes may be any size you wish. What is called "legal size" makes a nice case for clippings. These envelopes measure about four by nine and one-half inches.

Measure the envelope carefully and make the cardboards a quarter of an inch wider and longer. That is if the envelope is four inches wide, make the cardboards four and a quarter inches wide. If the length of the envelope is nine and one-half

inches, make the cardboards nine and three-quarters inches in length.

Now take the two-inch strip of material, which should be at least an inch longer than the cardboards, and paste all over one surface. Lay the cardboards upon this pasted surface, parallel, about half an inch apart. (See illustration 1.) Draw the cloth that extends at the ends to the inside and rub down smoothly back and front. (See illustration 2.) Now take the other strip, which should be the same width and a half inch shorter than the length of the cardboard, paste, and apply over the inside as a lining to the hinge. (See illustration 3.) Rub down well with the cloth. Now you have your cardboards joined with a cloth hinge.

Material for the cover is to be planned next. Perhaps paper is to be used. If plain paper is used it may be decorated either before pasting on or afterward, just as you choose. The cover material may show much of the hinge ma-

terial or not, as this is a matter of personal taste. When this point is decided on, allow a half inch extra on the three sides for turnovers. (See illustration 4.) Fold the paper on the edges of the cardboard, and you will see what the case will look like when finished. Where the corners fold over you will see little squares. These you must cut out carefully, and clip off the corners of the projecting laps. There is another way to do the cutting for the corners, but this is a very good way for beginners. Fold and cut the material for the other cover in the same way.

When both sides are ready, paste all over the back of the material. Start in the middle first and finish

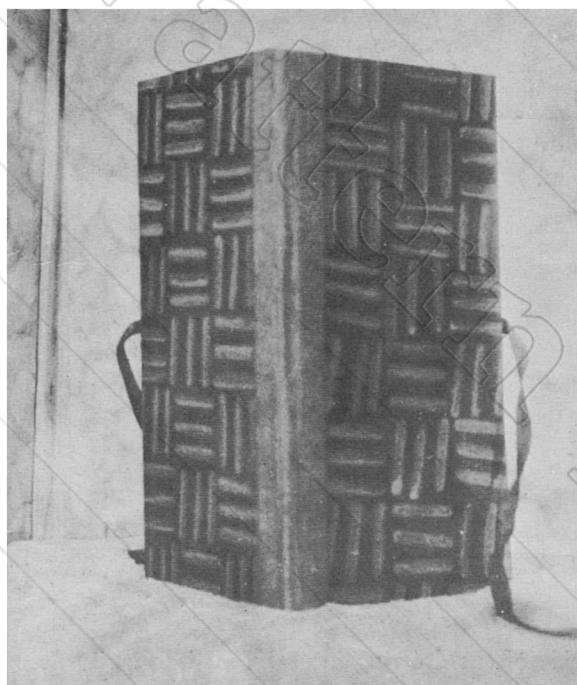

Clipping Case Made by Boy in 4A Grade. Cover paper block printed with common rubber eraser

pastings the edges last. Work quickly, for the paste soon dries. Now place the cardboard carefully upon the pasted surface, corner to corner and edges of cardboard on the creases. Lap over the turnovers, rub down, and then rub down the outside. The material should stick well all over. If cloth is used, work in the same way. Sometimes it is well to draw a line with a pencil where the folds are to come, as cloth does not crease as easily as paper. Now it

cardboards or several pieces of paper between the flap and envelope. (See illustration 5.)

A word about the decoration which can be put on the cover. If figured material is used no decoration is needed. Never use wall paper for a problem done just this way, as the wall paper, being very soft, soon wears out on the edges. Strong wrapping paper is excellent. This often comes in a pleasing brown and often in other attractive colors. Paper

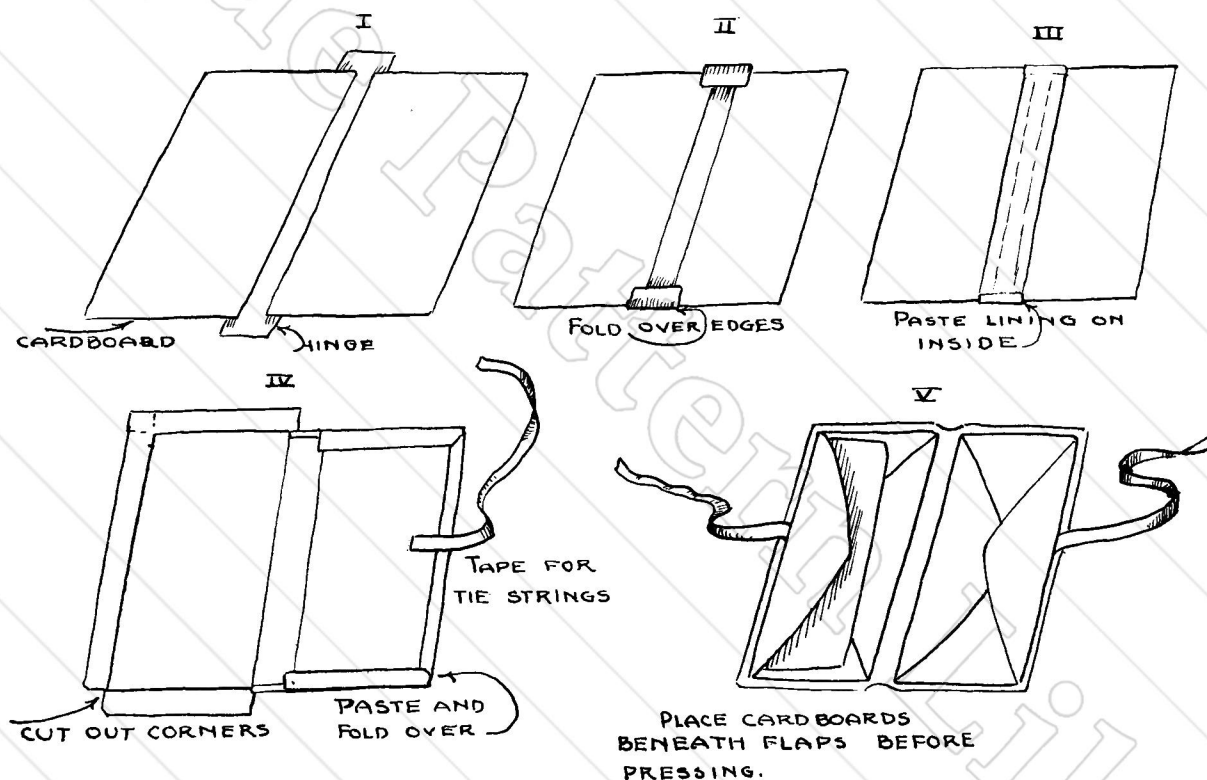

E.P.F. 1930

should look like the right side of the drawing in illustration 4.

Tie strings, which may be omitted if desired, are placed in the center of each long edge. They may be of tape or ribbon. They should be of some color found in the materials used. One boy in a class used a piece of orange-colored linen for his hinge. He block printed black paper with orange paint and then colored the tapes for the ties with the same water-color paint. He was very proud of the result, as he was only in a four A grade.

Paste all over the face of the envelopes and rub down smoothly. Be sure the envelopes are the same distance from the edge all round. The case should be put under a weight to keep it flat until it dries. Before doing this be sure to make the flaps of the envelopes open out, as the moisture of the paste will make them stick. Another way is to place

like this is easily decorated with printed patterns made with sticks, spool ends, bits of linoleum cut in odd shapes, and even rubber erasers can be used. A small eraser was used for printing by the boy mentioned. He made three parallel prints with opaque water color and turned his rubber at right angles and made three more impressions. The pattern in orange on black is very attractive. If desired the rubber may be cut into various designs with a penknife.

Plaid or large checked gingham blocked with a spool end in the white squares is interesting. Oil paint thinned with turpentine is useful for the paint. Unbleached muslin dyed and then block printed is often very artistic. A small stencil may be used, or a border can be drawn with a ruler and painted in. There is really no end to the combinations of colors and materials which may be employed in this problem, each producing a thing of beauty and usefulness.

Some Novel Weaves for the Ensemble

BY NELLIE SARGENT JOHNSON

NEW effects and different materials to use to gain them are always of interest to a weaver. Both the patterns and the yarns used for the weaving described below offer most interesting and unusual possibilities.

The yarns belong to the novelty group known as the ratiné or nub tweeds. The yarn mentioned below as Peasant has a white base thread twisted with a colored thread with small nubs or bunches of the color about every two inches or so. For a heavy material, colored Zephyr yarn is best to use for the pattern weft, using the Peasant yarn for the tabby. Or for a somewhat lighter material, Art silk for the pattern weft works up very well.

Persian Sparkle is a colored yarn twisted with gold so that the only color effect that is very noticeable is the gold. The colored thread is covered in such a way as to subdue its color, giving only a suggestion of the base.

The Persian Princess yarn is about the same weight as fabri. It is twisted with a variegated thread of rayon, which gives a very attractive glint. It differs from the other yarns described above in that it is suitable for either pattern weft

or tabby. Woven material made of this yarn is very soft and fine to the touch and of much lighter weight than any of the other yarns mentioned above.

It is important to remember that the cotton warps, such as 20/2 and 24/3, make a very harsh

material not at all pleasing in texture with these yarns as weft. For the best results, use fine all silk, fabri yarn, or No. 20 mercerized cotton for the warp, sleyed at 20 to 24 in the reed.

Now with regard to the pattern drafts. They are developed in a somewhat different method from the regular "overshot" weave in order to give a modernistic effect. Many different treadlings are possible with them. Interesting color effects can be woven on these drafts by weaving "on opposites." To

do this is easy. Choose a dark color, a light color, and still another color for the tabby if desired. On a regular treadle loom with the tie-up as given, treadle 1 with a dark color, treadle 3 with a light color, and then a plain tabby shot with the third color. Weave to square the block, or as many times as desired, then treadle 2 with dark color, treadle 4 with light, and then a tabby shot. On the Structo looms, it would be necessary for the same effect



Figure 1 (lower left)
Figure 3 (lower right)

Figure 2 (upper left)
Figure 4 (upper right)

to weave 3-4 with dark color, 1-2 with light color, then a tabby shot. Repeat to square the block, 2-3 with dark color, 1-4 with light, always remembering to use an alternate tabby shot after each two pattern shots. This may sound complicated, but it is really very easy to do.

Pattern No. 1 of the threadings as given was written definitely for the small Structo 8" loom using 240 threads. And it was on this little loom that the samples illustrated at Nos. 5, 6, 7 and 8 were woven. To put this threading on the loom, thread from the beginning to thread 122, then beginning with thread 121 repeat back to A. So that from A to B and back to A again is one repeat of the pattern. Twice this repeat gives a width on the loom of about 20 inches if sleyed 24 to the inch in the reed. This is very effective for runners, bags and pillow-tops, and offers a great many interesting variations.

Pattern No. 2 was written with the idea of modernistic effect for bags. It is not entirely logical or symmetrical, but makes very unusual bags. Those illustrated at Nos. 1, 2, 3 and 4 were all woven on this threading. An all silk warp of gold color was used, sleyed 24 to the inch in the reed. The detail of all of these will be described later. The pattern should be threaded from A to B as a repeat of 144 threads.

Pattern No. 3 is more logical than pattern No. 2, and similar in its results to pattern No. 1. It is excellent for pillow-tops, runners, portières in heavy materials, as well as for tweed sport dress material where modernistic effect is desired. And it is much better for this sort of thing than pattern No. 2. To put it on the loom, thread from A to B, and then from B back to A, giving a repeat of 213 threads.

In the bags illustrated in this article I have tried to show a few effective ways of using the novelty yarns, and also have given substitutions in case anyone wishes to have them. As wood tops are very popular at the present time, and also because they seem particularly fitted to these "crafty" looking wools, I have mounted two of the bags on these. On the other two bags, I used for one a new, very good-looking, inexpensive silver finish top, while on the other a 7" oval one of celluloid. This last one matches up very well with the gold color of the Persian Sparkle yarn of which the bag was made.

DESCRIPTION AND DETAIL OF ILLUSTRATED BAGS

Illustration No. 1 — Material mounted on a 8" wood straight top. Gold silk warp, sleyed 24 to the inch. Pattern No. 2, use three repeats giving a width of about 19 inches on the loom. For the tabby and the plain part of the bag, use Peasant yarn in henna and white, or any novelty yarns of

this color. Or if these are not available, tan Zephyr color No. 627 or No. 16 in henna, Bernat's Laurel or Glorine yarn in color No. 421 could also be used for the Peasant with equally good effect. The novelty yarns do not weave up well for the pattern; their effect is not clear enough. It is better to use a plain yarn, as Zephyr or Shetland, for the pattern. The color numbers in this article definitely refer to the Bernat line of colors so that the color effects can be easily duplicated.

To weave the bag as illustrated proceed as follows:

Tabby 40 shots with Peasant yarn in henna and white.

Then 1 shot plain tabby brown No. 627

1 " " " orange No. 15

1 " " " blue No. 795

1 " " " green No. 818

1 " " " yellow No. 703

4 shots Peasant yarn tabby, then

Treadle 3-9 times brown

" 4-9 " orange

" 1-9 " blue

" 2-5 " green

" 3-3 " yellow. (Center, repeat back to beginning.)

Illustration No. 2 — Material mounted on 10" redwood gate-top which fits the brown tones of the bag perfectly. This makes an interesting bag to carry with a tweed sport suit. Warp and pattern are the same as in No. 1. Tan Zephyr yarn No. 624 or No. 137 can be used as substitutes for the Peasant yarn if desired.

To weave proceed as follows:

20 shots plain tabby Peasant yarn in henna and white.

Then treadle 3-3 times brown No. 627

3 shots plain tabby with Peasant

Treadle 4-9 times brown. (Tabby with Peasant " 1-9 " " yarn between each pattern shot.)

" 2-9 " " "

" 3-3 " henna No. 16

" 4-7 " orange No. 14

" 3-4 " brown

" 4-7 " orange. (Center, repeat back to beginning.)

Then weave 20 additional shots of plain tabby for the handle.

Illustration No. 3 — Material mounted on a 7" oval yellow celluloid top. Woven with Persian Sparkle in gold and blue for the plain tabby. Warp gold silk as in No. 1 bag and threading No. 2. Pattern weft blue Zephyr yarn No. 795. If desired, Miro yarn in yellow No. 361 can be substituted for the Persian Sparkle with equally good effect.

To weave, treadle 1-4 times with blue Zephyr No. 795.

Then 4 shots plain tabby

Treadle 2-4 times blue. (Plain tabby shot of Persian Sparkle or yellow Miro yarn between each pattern shot.)

“ 3-4 “ “

“ 4-4 “ “

“ 1-4 “ “

“ 2-4 “ “

“ 3-4 “ “

“ 4-4 “ “

“ 1-4 “ “ (Center, repeat back to beginning.)

Illustration No. 4 — Material mounted on 8" oval silver top. Pattern No. 2 and gold silk warp as those above. Woven with Persian Princess yarn in green for tabby throughout, and green fabri No. 755 used for the pattern thread. This bag is very unusual and modernistic in effect. Also the fabric is very silky and soft to the touch. Bernat's Miro green yarn No. 374 can be used instead of the Persian Princess yarn if desired, and the effect will be very much the same.

To weave, first 20 shots of plain tabby with the Persian Princess yarn, then

Treadle 3-6 times with green fabri

4 shots of plain tabby

Treadle 3-14 times

“ 4-14 “

“ 1-14 “

“ 2-14 “

Repeat 3 times

Then treadle 3-14 times

4 shots of plain tabby

Treadle 3-6 times

20 shots of plain tabby with Princess yarn and, if handle is desired, weave at least 30 shots more of plain tabby.

Other color combinations that work out very well for this bag are black fabri with gray Miro

No. 359. A white or gray wrap should be used for this instead of the gold. Gray Miro No. 359 for tabby and the same yarn in orchid No. 378 or rose No. 351 for the pattern thread would look very well indeed with this same silver top.

Illustration No. 5 is a sample piece of weaving that was made as an experiment with pattern No. 1 on the small Structo loom. It is woven with Peasant yarn for the tabby throughout, with pattern in blue Zephyr No. 596, orange No. 14, and green No. 818. Tan No. 624 could be used for the

Peasant yarn if desired.

Weave 20 shots of plain tabby with the Peasant yarn.

Then treadle 3-7 times blue Zephyr. (Plain tabby between each pattern shot.)

Treadle 4-7 times blue Zephyr.

Treadle 1-7 times blue

Treadle 2-7 times blue

Treadle 3-7 times orange

Treadle 4-7 times green

Treadle 1-7 times blue.

(Center, repeat back to beginning.)

On the Structo loom use le-

vers 1-2 for treadle 3; 2-3 for treadle 4; 3-4 for treadle 1; 1-4 for treadle 2.

Illustration No. 6 is another sample which shows a very attractive treading of pattern No. 1. It was woven with plum-colored Zephyr No. 655, with tan fabri No. 624 for the tabby. The borders were woven with rose Zephyr No. 643, yellow No. 703, and blue No. 795. The lower border is about an inch in width and is woven as follows:

Treadle 3—once with yellow

“ 4-6 times rose

“ 2-6 “ blue

“ 4-6 “ rose

“ 3—once with yellow.

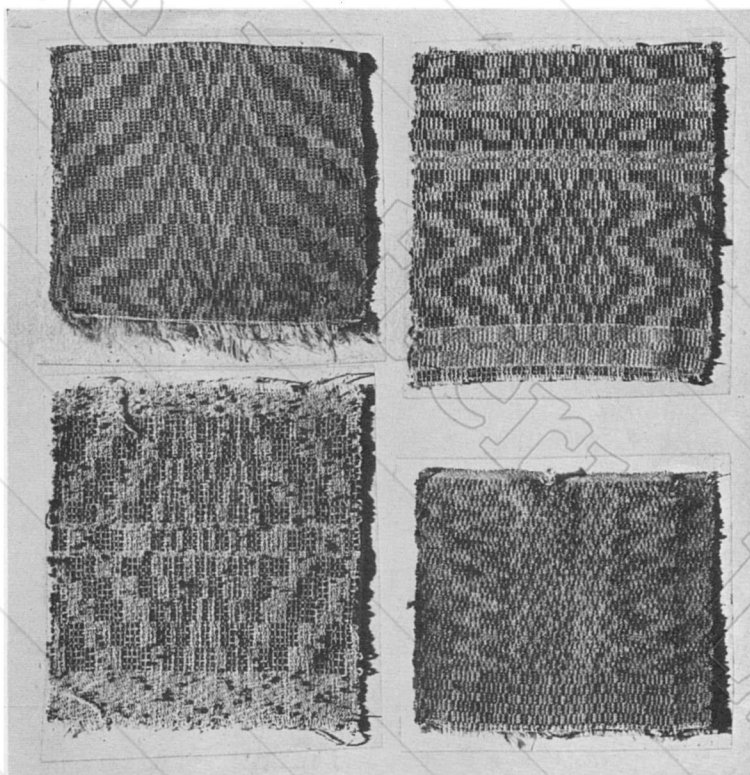

Figure 5 (lower left)
Figure 7 (lower right)

Figure 6 (upper right)
Figure 8 (upper left)

For the main part of the sample, weave as follows:

Treadle 1-4 times with plum. (Plain tabby shot
 " 2-4 " " " between each
 " 3-4 " " " pattern shot
 " 4-4 " " " with tan fabri.)
 " 1-4 "
 " 4-4 "
 " 3-4 "
 " 2-4 "
 " 1-4 " (Center, repeat back to beginning.)

The narrow borders at the top of the sample are the same treading as for the border described except that the number of shots on each treadle is less.

Illustration No. 7 is a sample made in a fine gold silk warp on the small Structo loom, sleyed 30 threads to the inch, using pattern No. 1 again. It shows still further variations of this interesting threading. The pattern weft was dark brown strand silk and the tabby a fine orange silk like the warp. To weave:

Treadle 3-4 times. (Orange tabby between each
 " 4-4 " pattern shot.)
 " 1-4 "
 " 2-4 "
 " 1-4 "
 " 4-4 "
 " 3-4 " (Center, repeat back to the beginning and back to the center as many times as desired.)

Illustration No. 8 — This is another sample woven on pattern No. 1, on the same warp and set-up as the last piece described. It was woven with black strand silk for the pattern thread, and tan strand silk for the tabby. Here again is an unusual modernistic effect in the wavy lines of the pattern. It will be noticed from this that a very interesting runner could be made if the pattern were threaded on a wider warp so as to show more of the repeat.

To weave, throw 10 shots of the plain tabby with tan silk, then

Treadle 1-7 times black strand silk
 " 2-7 "
 " 3-7 "
 " 4-7 "
 " 3-7 "
 " 2-7 "
 " 1-7 "
 " 4-7 "
 " 3-7 "
 " 2-7 " } Repeat 4 times or as many
 " 1-7 " } times as desired.
 " 4-7 "

Then treadle 3-7 times
 " 4-7 "
 " 1-7 "
 " 2-7 "
 " 3-7 "
 " 4-7 "
 " 3-7 "
 " 2-7 "
 " 1-7 "

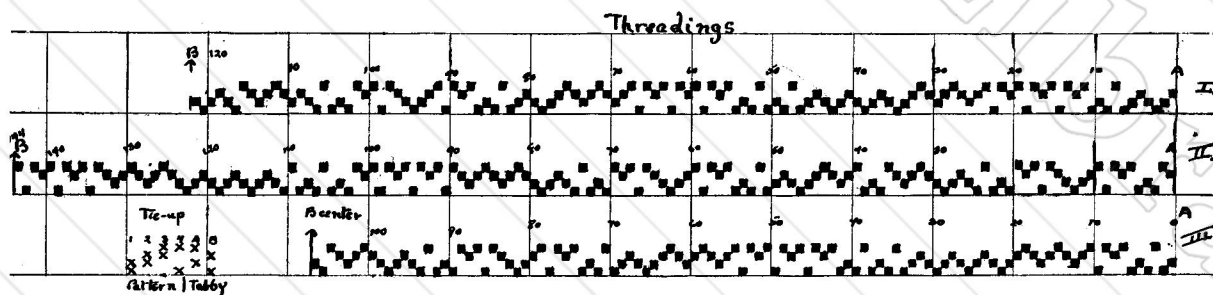

Threadings for the novel weaves



Spool and Box Furniture

BY MARION BROWNFIELD

WHO would think that attractive, useful and up-to-date furniture could be made from wooden spools and boxes? But the vogue for handcraft shelves, bookcases, dressing tables and many other pieces has made this style of furniture, when gayly painted, a decided asset to any room. Part of the trend has developed from the popular unpainted furniture that comes ready to decorate, and still another influence is the "Modern Art," which emphasizes individuality and simple lines.

The first thing is to gather as many wooden spools of all sizes, from the small half sizes that sewing silk is wound upon to the large ones that baby ribbon is reeled upon. Beg, and borrow from all your friends, and your shopkeeper! The red-painted spools that hold shoe button thread are both gay and strong. Small spools make useful handles!

The size to choose will depend upon the piece of furniture that is to be constructed. The fernery in illustration 1, for example, will need strong support. So the legs must be built of large strong spools. Those used merely for decoration, like the gallery around the top of the sewing stand in illustration 2, may be small and dainty. Or, different

sizes alternated are effective! One may use one's ingenuity and have delightful results.

Spool legs, however, require more support than iron glue to hold them firmly together. A curtain rod is useful and easily acquired at the ten-cent store, or steel stove rods obtained at a hardware shop are practical for slipping through the center hole of each spool. The latter can be fastened with a nut at each end — after the desired number of spools are strung together. The height of the legs are somewhat determined by the proportions of the box it supports. In general tall pieces need large spools, and low stands will be satisfactory with fewer and smaller ones. A footstool may be supported with groups of spools at the four corners, or spools may be placed sideways!

Choosing suitable boxes is another problem. For swinging shelves, or a bookcase, either of which the design in illustration 3 may be adapted, several boxes may be employed. For china cupboards or bric-a-brac the "modern art" scheme is often to choose several sizes and shapes of boxes and group them together like a flight of steps! A box placed endwise against horizontal boxes makes just the niche for some treasured vase or candlestick. These original arrangements lend themselves nicely to



Figure 1

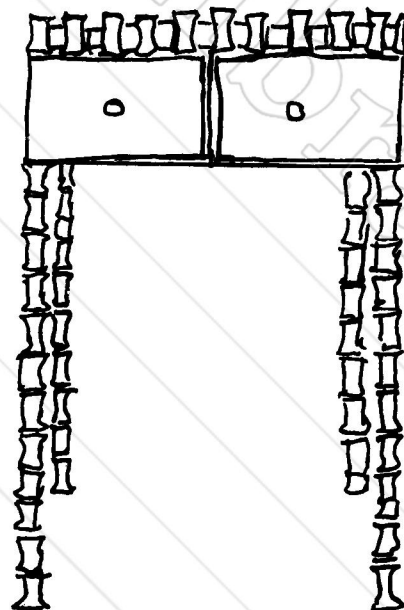

Figure 2

corners and odd niches that might otherwise be bare wall spaces. Shelves hung between a pair of beds can be attractively contrived simply of spools and boards so they may hold favorite books or a night-light. Sometimes a clever plan is to salvage an out-of-date table for the sake of its round top, and build up new spool legs which have the interesting lines suggestive of Old English or Jacobean period furniture. When painted in the cheerful modern mode, its former history will never be suspected!

The fernery illustrated here is best lined with zinc or sheet tin tacked in, to make it waterproof.

Painting spool and box furniture is an important finishing touch. If the boxes are soft pine, it may be advisable to "fill" the surface first with a coat of flat. White may be used if "flat" paint to match the finishing lacquer is not at hand. Brushing lacquer now comes which dries within an hour, leaving a shining durable coat. It takes, however, rather skilled quick strokes to spread it smoothly, so if there are details to paint a better plan for the amateur is to buy a slower drying lacquer or enamel and use turpentine to thin it as necessary when applied. This way one can take pains with "the corners," avoid brush marks and be sure of a neat job. Delightful colors include jade, coral, black, orange, lemon, Italian blue, purple, beige and black. Two-tone color schemes also are

highly favored. Thus shelves and spools may be lacquered one color and the inside of the "cabinet" another. Black and coral is distinctively modern. If the room needs brightening, orange in a brown and tan furnished room will be enlivening. If the room has light woodwork and wall paper, black or jade are good notes. A fernery may be lacquered to match woodwork. A distinctive effect is to paint the spools in alternating colors such as Chinese red

and gold. This would be charming for black shelves holding Oriental bric-a-brac. In this case, paint the spools before gluing them together.

"A single unique piece of furniture can often establish the tone of a whole place." Spool-box furniture can be devised for every room, but it fits in admirably for porch, sun room, patio or bed rooms where an "occasional" piece is needed to complete the comfort. Moreover, it is economical to make and can be made in a size to fit the space. In many modern small rooms the great problem is to get furniture of good proportions so that the room will not look crowded or ill-balanced. Among other pieces not already mentioned there may be contrived slipper seats, magazine racks, telephone stands and chairs, kitchen or bathroom cabinets, muffin stands, tea or coffee tables, writing tables and small-sized furniture of happy effect for the children's room or nursery.



Figure 3



The "Ensemble" Idea in Hand Woven Linens

BY CECILIA CLEVELAND WILLARD

IN our great-great-grandmother's day the weaving of the family table linen was one of the duties performed by the housewife and her maids and its production received very serious consideration. The first thought was for the serviceability and the decorative feature was confined to small threaded-in patterns which gave a tiny all-over diaper effect. Although a number of different threadings were used, the patterns resembled each other very closely and no great variety of effect was sought. Generally only unbleached linen yarns were used and the fabrics were later bleached. Rarely were colored threads used to emphasize the pattern. These linens were passed down from generation to generation and many specimens which survive to-day bear testimony to the painstaking care of the weavers of those days.

In this day of colored linens we can achieve on our hand looms effects that the Colonial ladies would consider slightly mad, but they suit our modern ideas of decoration and habits of life just as their fine and beautifully woven linens suited the austere interiors of their homes and their far less frivolous customs.

We have the inspiration of the colorful modern potteries, both imported and domestic, and the gospel which the interior decorators have so successfully broadcast in many magazines, is that all furnishings must harmonize and all the appointments of a room must be in keeping.

The possibility of adapting designs and weaving a piece of linen that will create a perfect ensemble with our favorite luncheon or tea service opens new fields of effort. The linens in the accompanying

illustrations were decorated with motifs taken from well known makes of modern pottery, in simple methods of modified tapestry weaving. They were woven on a four-harness loom threaded to the simple 1-2-3-4 threading and could, of course, be woven equally well on a two-harness loom.

One of the smartest shops in New York is featuring the combination of rayon with linen to produce distinctive and modern effects. Following this precedent the designs in the table linen illustrated were woven with Bernat's rayon floss. The effect is quite different and lovely. Strand mercerized cotton is also

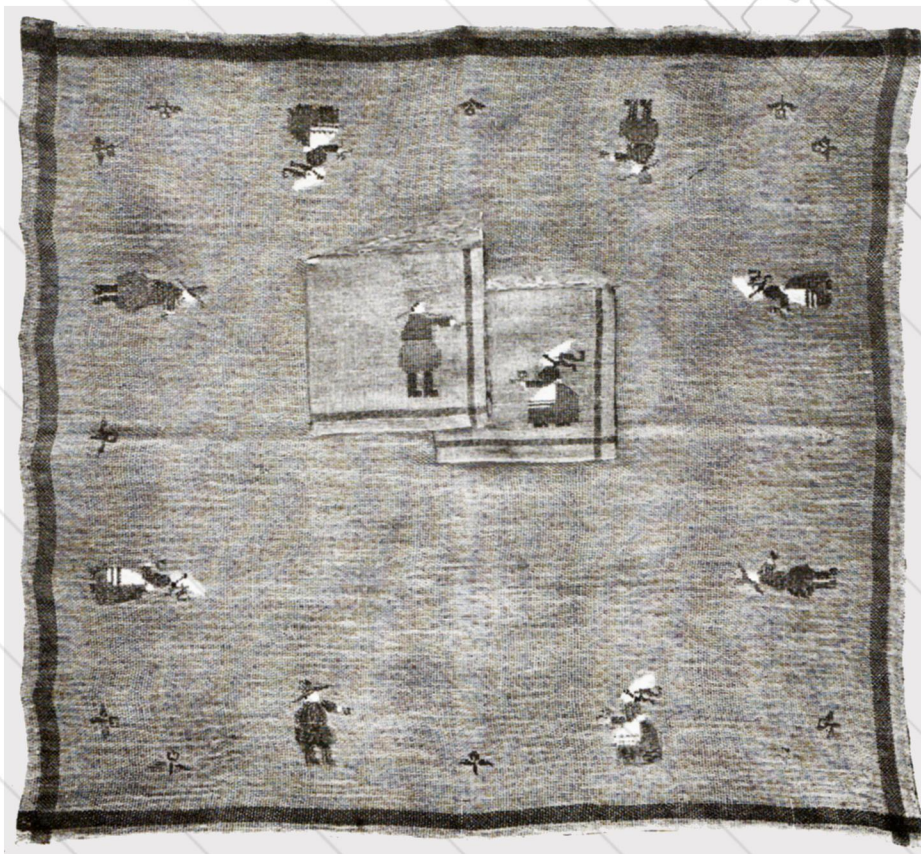
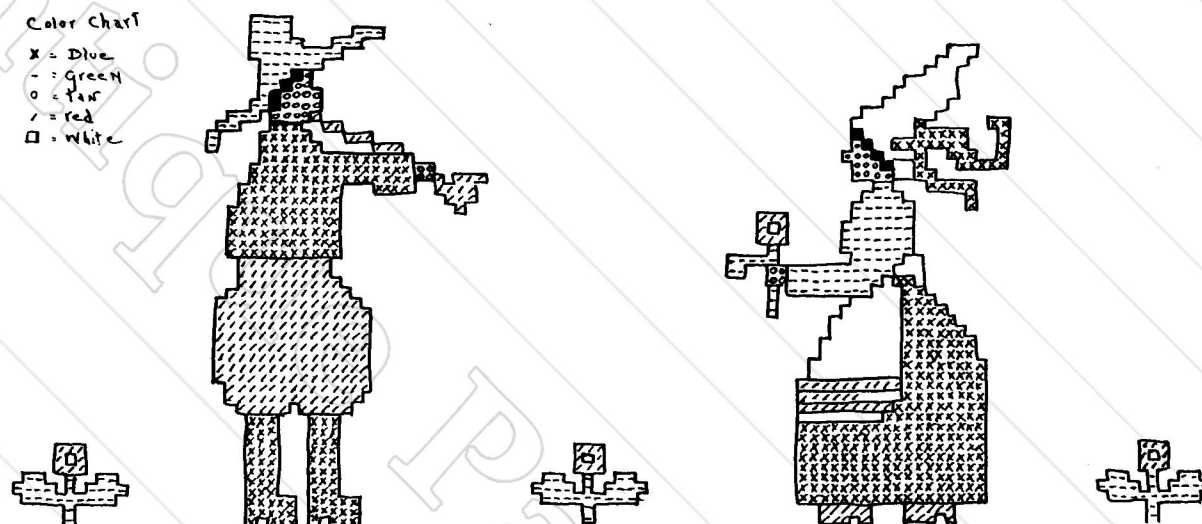

Illustration No. 1. Quimper Design. Woven at the Willa-Craft Studios



Weaving diagram and color chart for Quimper Design (Illustration No. 1)

very satisfactory used in this manner and it is announced that a new line of this yarn will be ready sometime this spring.

DESCRIPTIONS AND DIRECTIONS

The first illustration is a tea set decorated with the quaint little peasant figures taken from the famous Quimper ware. They are woven exactly as they appear even to Monsieur's pipe and the ribbons on Madame's bonnet. The colors are the simple peasant colors and are carefully copied from the pottery.

This set consists of a tea cloth 36 inches square and six napkins 14 inches square. The cloth is decorated with two figures on each of the four sides and a blue stripe set in one inch from the edge. The napkins have the blue stripe and one figure in the lower right corner. Three of the napkins have the men and three have the women.

The warp is the Special Natural No. 14 set in the reed at 15 threads to the inch. The stripe in the warp consists of 12 threads of Linen Weaver No. L. 206 set in 15 threads from the edge.

The weft is the same yarn that is used for the warp and is beaten up so that there are 15 picks to the inch, giving a rather coarse, loosely woven effect.

The napkins are woven on the same warp sleyed at 30 threads to the inch, and the stripe is the same number of blue threads as is used in the cloth. The weft for the napkins is the Tow Natural No. 20. They are beaten up more firmly than the tea cloth.

The method of finger weaving used is the simple embroidery weave, over two threads and under two threads on a flat warp, with the binder going across after each row of the embroidery weave. There are two warp threads to each horizontal block

of the pattern. Two rows (with binder) between form one vertical block. The pattern is followed and the squares are counted exactly as a cross stitch design would be worked on canvas.

TO WEAVE THE CLOTH

Weave two inches of tabby weaving, then twelve shots of the blue linen, then half an inch of tabby. First place the figures correctly by counting the threads in the warp and finding the exact center. The center of the warp must coincide with the center of the design. Then start laying out the design from the center to each side. For example —

Find by carefully counting the warp threads the two threads that will form the center block. The center in the design is the block that forms the stem of the flower between the two figures. Take a 10-inch length of green rayon and fasten it around the block by placing it under the two threads with the two ends on top of the warp. The end on the left side should be about two inches long. Now bring the long end over the two threads and poke it down under the warp. Do the same with the short end. This is the best method for fastening a thread preparatory to starting a new design or in adding a new thread. The length of the thread is governed by the number of blocks to be worked at that point of the design. It is unwise to use a thread longer than 18 inches or shorter than 6 inches.

Now that the center of the design is placed in the exact center of the warp, start counting the blocks from the center block to the right side and put in each part of the design that is on the same line with the starting point which is in this case the center block. It is important to remember that the design must be built up from the bottom to the top and it is impossible to go back and add blocks, unless they are darned in with a needle.

Count 36 blocks (or 72 threads) from the center block and start Madame's feet. Take an 18-inch length of red rayon and fasten it around the 37th block from the center block and go under the next block and over the next block, skip under one block and over the next. Skip three blocks and carry the thread over, under, over. Skip one block and go over the next. Now come back to the starting point by bringing the thread under the blocks where it went over before, and over where the thread went under. See Diagram No. 1. Now count 34 blocks and put in the block that forms the stem of the flower in the corner.

Start from the center again and count 36 blocks to the left and start Monsieur's boots. Go over the first block, under the second, over the third, skip under one block, over the next, skip one block, over, under, over, skip one and over the next one. Return to the starting point by carrying thread under the first block, skip one, under, over, under, skip a block, go under the next block and go under, over, under. Count 34 blocks from the heel of the boot and put in the one block that forms the stem of the flower in the corner. Throw the binder across. This forms the first row of the vertical block in the pattern. Repeat this row and throw the binder across. This completes the first vertical block in the pattern.

The thread used to put in the design should

always be kept under the warp and brought up between the warp threads at the point needed. When the article is woven and taken from the loom the work is finished by darning in the ends on the underside with a blount tapestry needle.

Totally different from the simple and substantial Quimper pottery is the lovely, fragile Venetian glass made on the Island of Murano. Its marvelous colors are produced by secret formulas handed down from father to son until the present day. Such fairy like beauty should have as its fitting accompaniment sheer hand woven linens repeating its lovely tones.

The square luncheon or breakfast cloth shown in



Illustration No. 2. Venetian Design. Woven at the Willa-Craft Studios

Color Chart
 □ = green
 X = yellow

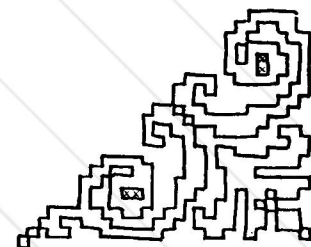
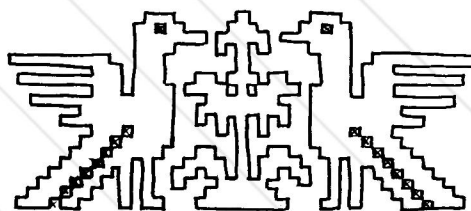
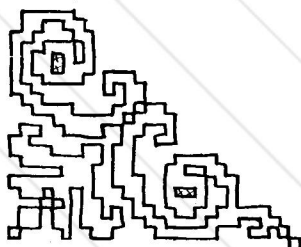

Weaving diagram and color chart for Venetian Design



Illustration No. 3. To use with Spanish pottery. Woven at the Willa-Craft Studios

Illustration No. 2 was designed to use with a beautifully shaped fruit bowl. The bowl is a lovely pale green with flecks of gold blown in the glass. Two graceful birds are perched on the rim of the bowl forming the handles.

The warp is 40/2 white linen warp and is sleyed in the reed at 20 threads to the inch. The weft is Bernat's Linen Special No. L. S. 220. This combination makes a beautiful pale yellow and contrasts

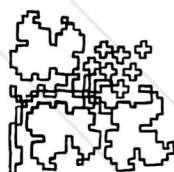

Weaving Diagram for Doilies in Wedgwood Design

Illustration No. 4. Design taken from Wedgwood Queens Ware. Woven at the Willa-Craft Studios

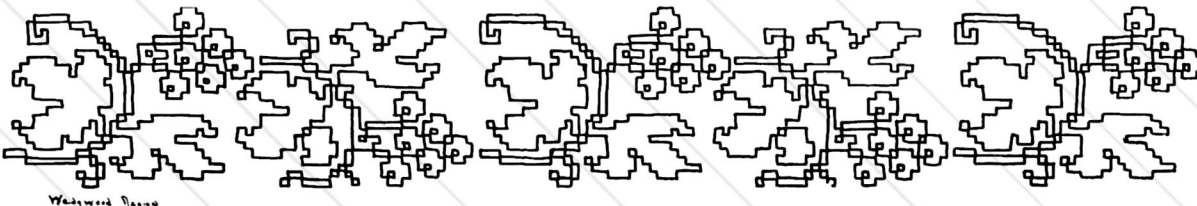

Wedgwood Design

Weaving diagram for Wedgwood Design

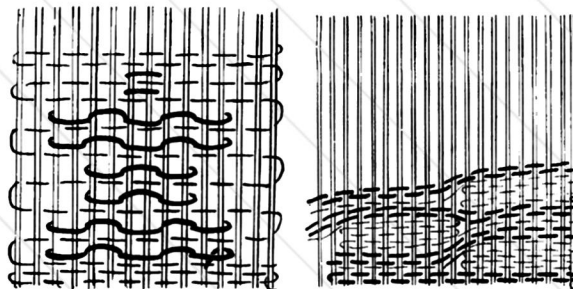
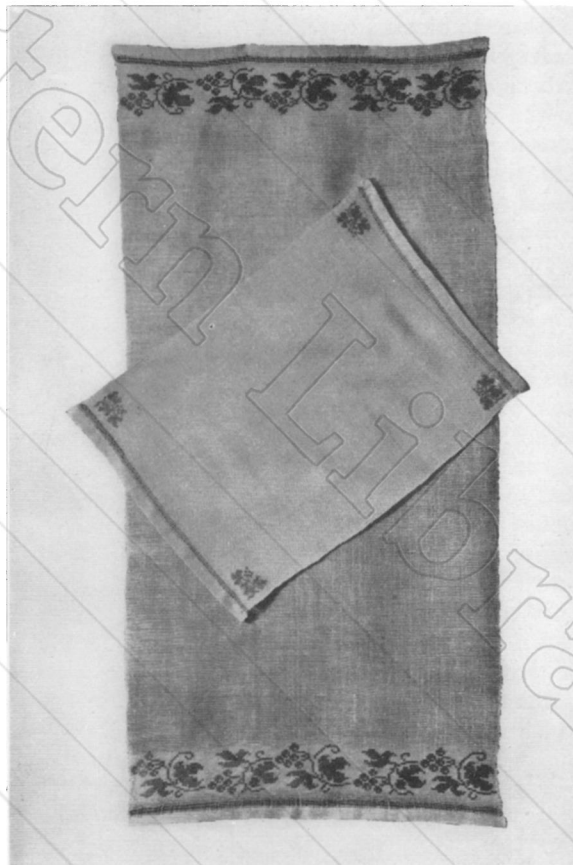

Diagram A and B. These Diagrams show weave for linens to be used with Spanish Pottery. (Ill. 3)

nicely with the jade green rayon (No. 232) used in weaving in the bird motifs. The cloth when finished is 42 inches square. The same method of Embroidery weaving that is used for the Quimper set is used here.

Spanish pottery is very gay and natural colored linen decorated in a rather set design and repeating the bright colors makes a stunning effect.



The warp used for the luncheon set in Illustration No. 3 is the Special Natural No. 14 and is set in the reed at 30 threads to the inch. The weft is the Tow Natural No. 20. The rayon flosses used are as follows: Blue No. 241, red No. 247, yellow No. 259, green No. 232, purple No. 254. The dimensions of the set when finished should be 20 inches by 60 inches for the runner and the doilies should measure 20 inches by 12 inches.

First weave 3 inches of tabby, then put in one shot of the blue rayon. Take about a 2-yard length of red rayon and on the "A" shed go under 18 of the top warp threads, change to the "B" shed, go back 9 threads, change the shed giving it a very gentle

tap with the beater, go forward over the same 9 threads, change shed, go back over 9 threads, change shed and go forward over the same 9 threads. Now go under 18 more threads, change shed, back nine threads, then forward again and so on across the entire warp. There should be 15 mounds of the red rayon with a space of 9 threads between each 2 mounds. Change the shed and put in one tabby shot of the blue rayon. The tabby should lie loosely in the shed but not so loosely that it puckers. Bring the beater down gently but firmly enough to make the blue tabby surround the red mounds. Change the shed and put in one more shot of the blue rayon and press it around the mounds with the beater. This forms the first step in the design. Continue by building up the 9 threads between the red mounds with the yellow rayon, in the same manner. A careful study of Diagram B should make this quite clear.

The yellow mounds are surrounded by two shots of purple tabby, always allowing the tabby threads to lie very loosely but not so loosely that they form little loops between the warp threads. This point is most important to remember. Now build up green mounds and surround with two shots of orange tabby which will complete the wide pattern border. Weave three-quarters of an inch of the linen and put in the narrow pattern border. Start with two rows of red tabby and build up blue mounds. Surround with two rows of red tabby and build up

yellow mounds. Next two shots of green tabby, two shots of purple tabby, two rows of orange tabby. This completes the narrow pattern border. Weave half an inch of the plain linen and put in two rows of green tabby, two rows of purple tabby and two rows of orange tabby. This finishes the end of the runner.

The doilies are woven on a warp 12 inches wide and are decorated by putting in a pattern stripe like the narrow stripe in the runner, weaving a half inch of linen, after that two rows of green tabby, two rows of purple tabby, two rows of orange tabby. Repeat on the other end.

Of all the beautiful potteries that have

been manufactured in England during the last two hundred years, there is none quite so lovely as the Wedgwood Queens Ware, so called because it was first made at the potteries of Josiah Wedgwood and presented to Queen Charlotte who gave her permission to have it known by the name of "Queens Ware." It is a beautiful creamy white tone and has a raised design of grape leaves and grapes in a shade of blue not unlike the so-called Alice blue.

The linen to use with this pottery was woven on a warp 18 inches wide and was sleyed at 20 threads to the inch. The runner measures 18 inches by 36 inches and the doilies measure 12 inches by 18 inches.

The warp is the Special Natural No. 14 and the weft is the white Linen Weaver. It is beaten up so there are 20 picks to the inch. The design is woven



Illustration No. 5. Della Robbia Design. Woven at the Willa-Craft Studios

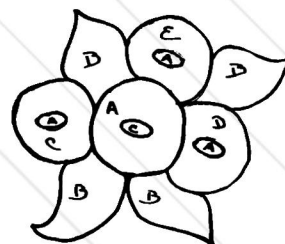

Color Chart

A = Orange
B = Green
C = Yellow
D = Dark Yellow
E = Pale Yellow

Della Robbia

Color chart for Della Robbia Design

in with the Embroidery Weave method. Blue rayon floss No. 205 was used for the design.

The brilliant Della Robbia ware comes from Italy and its realistic fruit design seems especially suitable for the breakfast table. This ware comes in two colors, yellow and blue with the fruits introducing many other colors. The linen in Illustration 5 was designed for a yellow set.

The warp is the Natural No. 14 and is 18 inches wide. It is sleyed at 30 threads to the inch. There is a stripe in the warp consisting of 10 threads of Linen Special No. L. S. 239 set in 20 threads from each edge. The weft is the Half White Linen Special.

The method used for putting in the design is the

simple laid in modified tapestry. The design was drawn on paper the exact size that the decorations are to be when woven, and colored with crayons in the colors that are to be used. The design was then pinned to the tabby heading underneath the warp threads and woven in free hand by following the design instead of counting threads. The tabby goes over after each row of the laid in threads.

The illustrations and directions given above will no doubt suggest to clever weavers many other possibilities for designing fabrics to accompany different types of ware, both domestic and foreign. In the charming effects that can be created the weaver will find ample reward for her originality and skill.

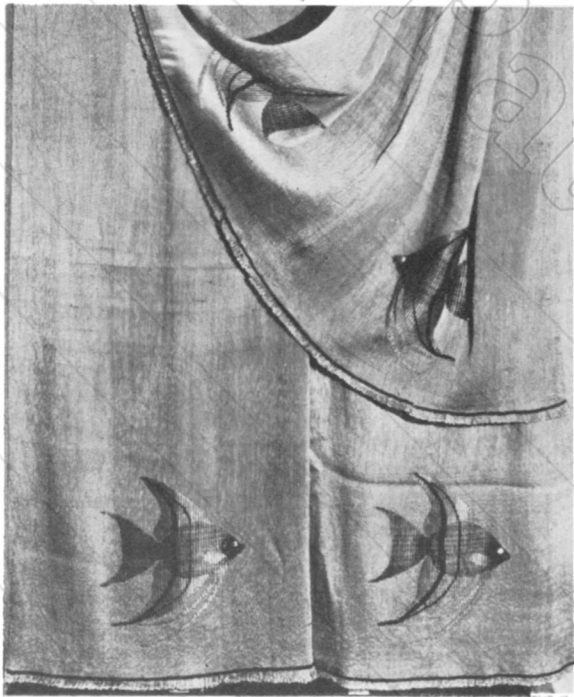

Variations of the Embroidery Weave from an article by Edith H. Snow in the July, 1929 Handicrafter





LOOKING *at the* CRAFTS



—MARJORIE B. AMES, EDITOR—

THE American Federation of Arts is rendering a great service in its annual exhibitions of the lesser arts and the crafts. Glass and rugs were the contributions in the current exhibition and the examples displayed were gathered from the United States and Europe. The exhibition is now making a circuit of American museums and it is to be hoped that all craftsmen and craft lovers will avail themselves of the opportunity of viewing it.

A great disparity exists between the artistic quality of the glass collection and the assembled group of rugs. The glass, taken as a whole, is comparable with the products of any period though it be Venetian, Bohemian, Colonial American, Persian, or Roman; the rugs, however, presented a sorry picture and in many cases were good examples of what ought not to be instead of fit subjects for study in contemporary rug making.

So much concern is evinced over the present state and the eventual future of the crafts, that this gorgeous showing of modern glass work is encouraging and belies those views which say our decorative arts are decadent and rapidly moving towards extinction. The plethora and high quality of the glass indubitably means that the glass industry is flourishing and well capable of standing up alongside the craft industry of any period. As so many descriptive articles have been written on the exhibition, it seems more profitable in this short article to endeavor to analyze the reasons underlying the flourishing state of the craft in glass than to devote the space to further description.

Glass making, because of its scientific technique, cannot be successfully practised as a home or amateur craft. A great deal of knowledge, much train-

ing, and good equipment and materials are needed for complicated pieces, and unusual textures. Also the glass worker must be as much a scientist as artist. He cannot, as the painter, take some tubes of paint, brushes, and canvas and then go ahead with his production. He must have knowledge of the chemistry of glass making, possess glass

furnaces, and give thought to scientific production. All he attempts is circumscribed within the body of the technique, and at all times he must consider whether it can be done.

These limitations have apparently reacted to the welfare of the modern glass worker. The advances in scientific method have enabled him to obtain textures and delicate lines that were beyond the guild craftsmen of older periods. Even the filigree glass of the Venetians pales in its delicacy of line beside some of the pieces exhibited. Apparently the modern glass workers have been alert to scientific advance and have made technical progress

the servant in art at every stage in the advance.

Though some of the glass was garrish, most of it evinced the restraining influence that resides in production for a diversified buying public. The workers tastes were subordinated in some measure to popular appeal. Because of the investment in equipment and the need to produce in number, glass making has many of the attributes of an industry. The European glass showed more variety and originality than ours, and perhaps the explanation lies as much in the productive problem as in their mastership of the art. Talent, raw materials, and production costs are not as high abroad as in the United States; consequently they can put more time in design and produce wider varieties in smaller numbers than we can. Proportionately the return

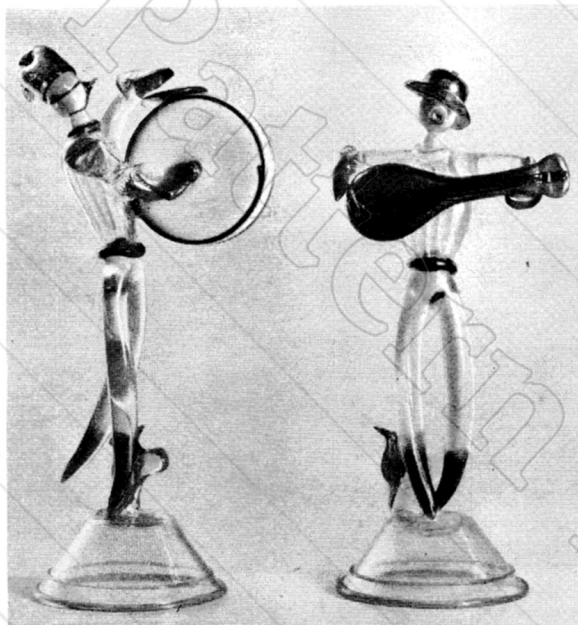

Courtesy of Metropolitan Museum

Italy. Catalog No. 244. Designed and executed by Aestri Vetrai Muranesi, Cappellin E Ci. Exhibited by MacAlister & Alvord, New York, American Agent. Group of dancing figures, blown glass

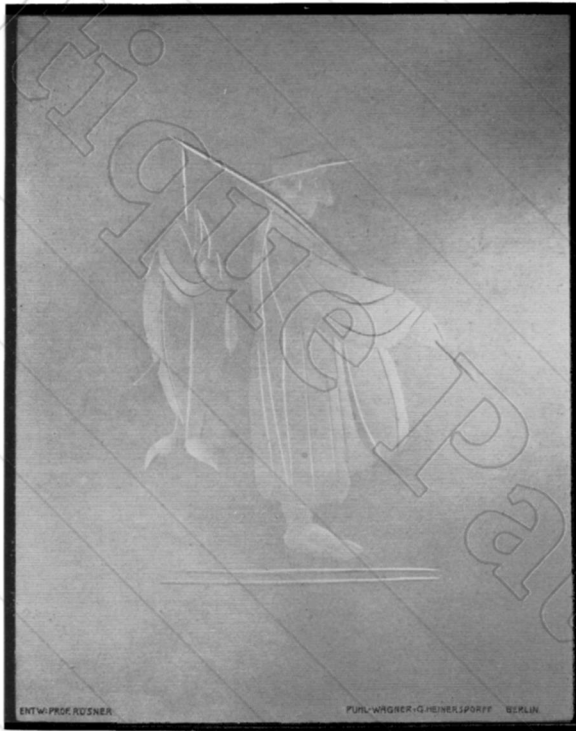

Courtesy of Metropolitan Museum of Art

Germany. Catalog No. 201. Designed by Georg Walter Rossner. Executed and exhibited by Publ & Wagner, Berlin. Panel, Fisherman, cut glass. American Agent, Ravenna Mosaics, Inc., New York City

received on the outlay need not be as large as with us. A study of the set up of these glass making establishments might go a long ways towards informing us under what conditions one can expect successful craft industries.

As the writer stated in commencing the article, the rugs present another picture. The majority of them were designed in rampant modernism and unbearable in color and design. Modernism, to survive, must pay some attention to natural feelings and to the laws of design as established through survival. Experience has taught the human race that latitude can be given in art; yet there always remains the interplay of utility and beauty. A rug is created for a floor covering, and consequently should play a subordinate rôle in the scheme of decoration. Paul T. Frankl, one of the greatest zealots in modernism, would banish all design from rugs because of this fact; and it was strange to see an opposite school making of their rugs a field of violent colors, fast moving and angular lines, and leaving one with a feeling of insecurity.

Though the Persians designed their rugs for room schemes that were often devoid of furniture and possessed little color outside of the rugs, the writer feels their productions have more place in a Western home than these violent modernistic

creations. Experimental psychology is discovering what an important rôle environment plays in one's mental welfare, and these unstable productions, if put on the floor, certainly could not help one towards arriving at peace of mind.

Here and there amongst the rugs displayed were examples of modernistic design that were pleasing, and the creators of these are on the right track. Apparently they realize that one cannot throw overboard all the conventions of technique and design; also that one can produce original creations, imbued with the modernistic spirit, that are still satisfactory from the standpoint of rug utility.

In both the glass and the rugs a contemporary spirit was displayed. Much of the subject matter was taken from the world around the designers and, outside of some semi-classical patterns no tendency to lean on antique designs and conceptions were apparent. There was a rug with scenes from Long Island sport life; glass panels with humorous depictions of fishmongers and policemen; water pitchers with representations of the horse race track and tennis matches; and designs based on the angularities and mass structures of the machine, concrete, and steel. This is a commendable trend



Courtesy of Boston Museum of Fine Arts

United States. Maker: Ruth Reeves. Rug, Aegean; machine-made, blue, blue-grey, and rose-henna wave design. Quantity production, executed and exhibited by Bigelow-Hartford Carpet Company, New York City

and should be encouraged in all modern art expression. Our contemporary life certainly affords enough of interest to enable us to gather all we need of illustrative design material from what is around us instead of harking back to older periods. In our exploitation of contemporary design we must avoid photographic realism; that would soon bore. But with the addition of the playful spirit there will always exist a piquant charm and room for individualism as well as pure design structure.

THE WEAVERS GUILD OF ST. LOUIS

The Weavers Guild of St. Louis was formed four years ago by a small group of women for the purpose of studying the various types of textiles which can be executed on hand- and foot-power looms. These weavers, Mrs. Edmond Wuerpel, Mrs. W. John Harris, and Mrs. E. C. Rowse, who had been studying the craft of weaving at the St. Louis School of Art, with the coöperation of Miss Lillian Glaser, the instructor, determined to form a guild, believing such an organization would go far toward maintaining the high standard of weaving taught in the school, as well as stimulating an interest in the art of weaving in the community.

The Guild functions in many ways; it has loaned samplers of weaving to the women of the Ozarks, thereby giving them the correct idea of the standard of design and workmanship desired by the public, thus promoting a ready sale for their work.

The Guild is composed of active weavers and of associates who are interested; it meets once a month in the Art School through the courtesy of the director, Mr. Wuerpel, when exhibits loaned by weavers from all parts of the United States are explained by one of its members after which ideas are exchanged with general discussion, over a friendly cup of tea.

From the Carolina Mountains to Berea, from the Talbots and Davenport weavers and from Miss Snow's studio, New York, came examples last year. The Far East, China and Japan, Russia, Rumania, Italy, Scandinavia, and South America will be topics and examples this year.

The Guild held its first exhibition in St. Louis last November, when the weaving wrought by its members was shown.

Bags, towels, luncheon sets, table runners, samplers, coverlets, tapestries, transparent and solid, were the pleasing results.

A representative exhibit of the work of the Guild members is now being prepared to be sent to the Arts and Crafts Society of Boston beginning March 24 to April 9.



In Looking at Crafts

Amongst the interesting developments in crafts is the introduction of the real oriental knot in rug making as a home project. In the last few years rug-crafts have been popular; included were the hooking, cross stitch, and woven rugs; but little was done with the hand tied knot outside of schools and occupational therapy shops, yet the knot makes the most enduring of rugs and enables the worker to produce gorgeous creations like the Persian rugs.

Through the instrumentality of Mr. Charles A. Ridd of Glendale, California, the hand knotted rug-craft has been introduced in several California department stores. Several years ago, Mr. Ridd reached the conclusion that the average woman would be fascinated with this craft and that it had a distinct place amongst the home arts for the products were artistic and the work itself full of charm. He spent two years developing the technique, perfecting the frame and other paraphernalia; and also in actual experiment with the subject — the American woman. With the assistance of Emile Bernat & Sons Company the Persio wool was developed for the craft. This yarn has the same bodily structure as the wools used in Persian rugs, and it is lustrous, long wearing and dyed in subtle tones that vivify and sparkle with wear.

One unusual feature in the project is the fact that the worker is encouraged and assisted in creating her own designs. Many women have found that their creative powers are awakened and that they are able to produce delightful designs that they can call their own. This personal touch makes the completed rug a treasured possession and make the trouble and expense incurred well worthwhile. Demonstrations have already been held at Jordan's Inc. in Pasadena, The Wise Company in Long Beach and the Broadway Dept. Store in Los Angeles. All were under the direction of Mr. Ridd and he expects to continue giving them in various stores on the Pacific Coast.

AN ARTS AND CRAFTS TOUR OF NORWAY AND SWEDEN

The marvelous handicraft of the craft workers and weavers of Sweden easily ranks with the very best produced in any other country, and in many instances it far surpasses in beauty, technique, design and originality.

The modern Swedish craftsman has inherited an instinctive sense of decoration from the past. For more than five thousand years the same race has inhabited the country, and there has been very slight intermingling with other peoples.

In May of this year there will be opened, in Stockholm, an Exposition of Arts, Crafts and Home Culture, having for its definite aim the illustration of Sweden's contribution to the present-day efforts to give to homes, home furnishings and household objects, especially those intended for the public at large, esthetic and good quality through the cooperation between industry and artistic talent and to exemplify also the results of analogous efforts in allied domains.

The Exposition will be divided into two main sections, the first containing the display of means of communication, objects of household and home furnishings, productions of art industries, etc. The second section will contain entire homes, apartments, gardens, streets and objects belonging to them.

There will be shown household and decorative objects of leather and metal; furniture of all kinds; ceramics and glassware which will offer special interest, judging from the high standard of originality and artistic effect reached by Sweden's porcelain and glass works.

Exhibits of book bindings, graphic arts and printing; products of modern Swedish textile work such as carpets, hangings, tapestries and covers; ecclesiastical textiles; all of these together with most extensive exhibits of Swedish handicraft and home industry, showing the ancient traditions of culture and art, which are the worthy fore-runners of the present-day art industry and home culture.

An unusual opportunity to visit this Exposition and much of Sweden, Norway and Denmark is offered this coming summer at a very reasonable expense. A party will sail on the Swedish-American "M. Kungsholm" from New York on July 2. Its aim will be to visit the most interesting places in these countries, the historic collections of art, handicraft and historical relics. Schools of handicraft, workshops of craftsmen and weavers will be inspected. A marvelous scenic trip by boat, train and motor through Sweden and Norway, down a part of the beautiful west coast of Norway, then over mountains through forest and farmlands. The art museums and handicraft museums at

Gotenburg, Stockholm, Gripsholm Castle, Rattvik, Mora, and Leksand in Sweden; Trondhjem, Bergen, and Oslo in Norway and Copenhagen in Denmark will all be visited. There will be ample time for members of the party to look up things of individual interest. This Arts and Crafts tour of Scandinavia will offer a most delightful, interesting educational opportunity for those engaged in working in, or teaching craft work, or interested in interior decoration and architecture. Detailed information concerning this tour may be obtained from Frank E. Mathewson, Secretary, Eastern Arts Association, Dickinson High School, Jersey City, N. J.

(Continued on page 47)

For Sale

Small pieces of old hand-woven coverlets, to be used as weaving patterns. Also some homespun Antique linen, for crewel embroidery.

MRS. R. P. M.

Box 64, R. F. D. No. 2 Richmond, Virginia

Your Advertisement in

THE HANDICRAFTER

will benefit from . . . the circulation list of the HANDICRAFTER which reaches practically every craft worker in the country as well as schools, libraries and occupational therapy centers.

. . . the reader interest which the HANDICRAFTER arouses by the quality of its contents containing practical, constructive and cultural articles by leaders in every phase of crafts.

. . . the constantly improving appearance of the HANDICRAFTER, its steady increase in size, and distinct improvement in typography and illustration.

and

. . . You may take great advantage from the present *low advertising rates* enabling you to reach an unexploited and unexcelled market for your craft products at minimum expense.

Advertise in THE HANDICRAFTER and watch results roll in.

Write for Rate Card

THE HANDICRAFTER

Jamaica Plain, Massachusetts

Book Reviews

ORIENTAL ART. The Macmillan Company. Price, \$12.50.

CHINESE ART. The Macmillan Company. Price, \$12.50.

THESE two books are commentaries on the advantages the modern art worker possesses over the student of previous ages. Advances in the art of printing, both black and white as well as in color, have given him a tremendous amount of material which he may have for his own — material which in olden days was accessible only by actual ownership of the art objects, through examination and sketching of collections, or through the purchase of beautifully wrought but dear books of engravings.

It has always been recognized that it is necessary to study the works of other men and periods to develop an individual style. Art history shows a continuous but diverse solution of the problems of color, design, and technique, and every progressive artist or craftsmen wants to familiarize himself with these to create his own. Today when books such as these are placed before us, we may study textiles, pottery, glass, bronzes, and furniture from the representative art collections of the world without leaving our desk or easy chair. The publishers have endeavored to supply in single volumes a comprehensive view of the arts of several Oriental countries. The books are beautifully printed and profusely illustrated with color plates.

There is so much about us, and the time we have is so limited, that unless we have developed a hobby in some particular art, we prefer books of this sort which touch the important aspects alone, yet are not superficial, to specialized treatises.

The arts of the Orient are great; basically they are so different from ours that we can add a great deal to our understanding and to our art capability if we absorb what they offer. In these books, the textile designer finds reproductions of gorgeous weavings, rugs, embroideries, and velvets; the ceramic and glass workers are afforded a wide range

of illustrative material on Chinese and Persian pottery, porcelain, and glass. Everybody interested in color will appreciate these works, for Oriental artists are masters in color, and though they are not as naturalistically-minded as we are, in the decorative and abstract spirit they are preëminent.

BEADCRAFT by *Idalia B. Littlejohns*.

RAFFIA by *Annie L. Begg*. Pitman's "Craft for All Series." Price, \$1.00.

AMONGST the recent publications of Sir Isaac Pitman & Sons, Ltd., are these two volumes on crafts. Both of them deal with popular crafts and treat the subjects in an erudite way. The book on beadcraft treats the subject from every angle, being copiously illustrated with diagrams, sketches, and plates of finished beaded pieces. Though beading has always been a live craft, for some reason very little has been published on the subject and consequently this book is timely in its appearance. It is so thorough that the art teacher and craft worker will find it sufficient for their needs.

Within the last few years, raffia has become a popular craft medium. Also raffia has been introduced in the present-day styles, and many chic articles of wearing apparel, like bags and hats, have been developed in it. As so many schools, camps, and therapy shops include raffia work in their list of crafts, the place for this book in the craft library is established. In its treatment of the subject it is just as thorough as the volume on Beadcraft.

In a previous review of books published by Pitman, the writer took space to complement this publishing firm on the great work it is doing for craftsmen in making these valuable books so accessible to the public through their inexpensiveness. When one stops to think of how much can be secured for a small sum, it seems astonishing. Artistically there is a little wanting, for much of the design material given is not above the elementary, but from the technical standpoint they are undoubtedly of high excellence.

HANDICRAFT SPECIALTIES

TOOLS - MATERIALS - INSTRUCTION

Handbook of Projects Instruction

In Leather Craftwork — also Bead, Porcupine Quill, Feather, Horsehair, Stone, Horn, Celluloid, Indian Silver and Turquoise. Try our *Material Supply Service* for Individual, Class and Club Handicraft.

1928 Handbook 50 cents; 1929 Supplement 25 cents
Price lists and leather samples included

LESTER GRISWOLD

623 PARK TERRACE COLORADO SPRINGS, COLO.

Mail This Coupon Today! •

The HANDICRAFTER, 99 Bickford St., Jamaica Plain, Mass. Please enter my subscription to The HANDICRAFTER for one year. Enclosed please find \$2.00.

Name

Address

City

• For the STRUCTO Artcraft Loom No. 600

WE OFFER A WIDE VARIETY OF WOUND WARP BEAMS. THE VARIOUS BEAMS OFFERED ARE IN STANDARD YARNS DISPLAYED ON THE BERNAT WEAVRITE CARD. DESCRIPTIONS AND PRICES ARE AS FOLLOWS:

ART. 6001—

Cotton warp No. 20/2. White. 590 end. 20-yard lengths\$4.50

ART. 6002—

Egypt warp No. 24/3. Natural. 590 end. 20-yard lengths\$6.50

ART. 6003—

Linen warp No. 40/3. White. 590 end. 10-yard lengths\$9.00

ART. 6004—

Linen warp No. 20. Natural. 590 end. 20-yard lengths\$9.00

ART. 6005—

Mercerized warp No. 20/2. Natural. 590 end. 20-yard lengths\$6.50

ART. 6006—

Warp. No. 24/3. Tan. No. 249. 590 end. 20-yard lengths\$8.00

ART. 6007—

Egypt warp No. 24/3. Black. 590 end. 20-yard lengths\$8.00

ART. 6008—

Fabri worsted warp. White. 300 end. 20-yard lengths\$9.00

ART. 6009—

Fabri worsted warp. Tan. No. 136. 300 end. 20-yard lengths\$9.00

ART. 6010—

Spun silk warp. White. 590 end. 10-yard lengths. \$9.00

ART. 6011—

Spun silk warp. Gold. 590 end. 10-yard lengths. \$9.00

FOR the Structo Loom No. 240 we offer the sectional warp beam wound in cotton, warp 20/2, at \$1.35 for a five-yard beam.

Write us for catalogue covering Structo Loom in all sizes, loom accessories and winding equipment

EMILE BERNAT & SONS CO.
89-99 Bickford Street, Jamaica Plain, Mass.

EDITORIALS

(Continued from page 2)

For his yarns the weaver went to the wool merchant and the Dyers Guild; thus, as is seen, the tapestry atelier was confined to the actual weaving and depended on others for the carrying out of incidental steps. In other weaving centers we read of constant complaints because the weavers could not secure good cartoons or satisfactorily dyed yarns and often had to do this work themselves though they realize they lacked the requisite skill. In the great Persian rug-making centers an art like dyeing was so specialized that some dyers confined themselves to blues or reds alone, and the rug maker had to rely on a half dozen dyers for his yarns; but today we consider these rugs amongst the most glorious masterpieces of color in existence.

The past does not tell us that we must carry a thing through from its elementary stage to the finished product if we desire to work in a true craft spirit; it reveals to us that flourishing crafts come from combinations of workers, skilled in their own fields, with each craftsman or worker carrying out the step suited to his capabilities and all actuated by a desire to do their best. Men like William Morris, in their desire to escape from the sordidness of the early mechanical age and revelling in the naïvety of medieval Europe, concluded that we must revert to semi-primitivism to attain sincerity. Not at all; we must advance with the desire to achieve beauty, exploit originality, and eventuate durability. Just as the Brussels tapestry center was built on specialization to attain good production, so must we; whatever improvements in method or material come to hand should be utilized; and so long as we employ discriminating intelligence, our arts will evince progress and sincerity.



FILET

(Continued from page 24)

larger than the piece of net to be mounted.

To mount the net, sew first the four corners to the four corners of the frame, then sew the sides of net to the sides of the frame, passing the needle through each mesh of net, but around the frame. A fine knitting cotton makes a good basting thread. Care must be taken not to pull the thread too hard on any one mesh, or the net may snap at a knot, with the too sudden strain. The net must be tight and firm and perfectly even in the frame. A very large piece of net must be mounted two or three times, as a frame larger than 36 inches is difficult to handle, and so it is easier to mount one section of the net, one corner and down two sides of the frame, then fold over the loose net, and baste to the other two sides.

The pattern is worked to the end of net mounted, the threads allowed to hang until net is changed, when they can be picked up and pattern continued. The two-yard piece of net illustrated will be mounted four times in a frame 36 inches square.

As this article is entirely about nets, the weaving of the patterns, and the different stitches used, and various types of "Filet," must wait for a later issue. Also a little of the history of lace, and the many uses to which it can be put today, and how it was used in the past, when lace was not a whim of changing fashions, but a beautiful fabric, wrought and worn by queens and noble-women, used to decorate their palaces and churches, and treasured so that it has been preserved and handed down to us, that we may see and know a part of women's work of the Middle Ages.

HAND MADE BOOK ENDS

(Continued from page 13)

before trying to straighten the metal unless it gets badly out of shape. Several reverse bends or a few well directed blows will sometimes give the de-

sired result. This operation of straightening and "peening" is rather difficult for the novice and, unless you have done such work before, it might be well to practice a little on a piece of scrap metal. The novice usually finds the metal bending in the opposite way from that desired.

The next operation is bending. Place the work in the vise and bend back the top and sides, leaving the cut out base piece standing towards the unfinished side as shown in Illustration No. 3. Be sure to hold the work firmly in the vise between two pieces of soft wood or leather and press both sides down evenly at the same time. Complete the finish rubbing or polishing if necessary, and give the whole article a thin coat of transparent lacquer, with a camel's hair or badger brush. Clear "Duco," or any similar lacquer, is good.

The designs and patterns for this work are practically unlimited as cheap steel or galvanized iron decorated with colored lacquers may be used, and are very attractive. Your monogram in bass-relief is also very effective in place of the cut out work, and may be made by hammering on the back side with a blunt pointed tool using many light blows,

STRUCTO ARTCRAFT LOOMS

are easy to warp and operate

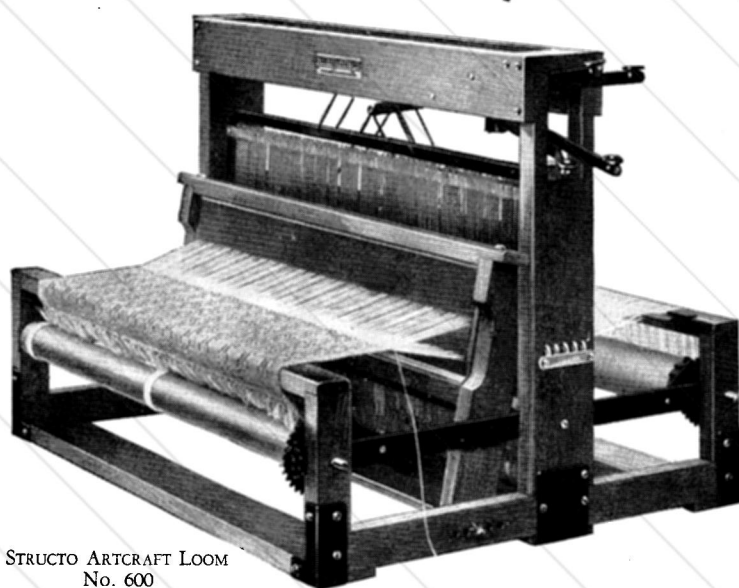

STRUCTO ARTCRAFT LOOM
No. 600

They are designed for table use and the home craftsmen will appreciate the simplicity of mechanism and the ease with which they can be moved about. One can always take the Structo on one's summer wanderings.

To the large weaving studio the Structo Looms offer the advantage of being excellent experimental and auxiliary looms. With the Structo No. 600 in your studio, the making of your narrow weavings and experimental fabrics is taken care of.

Write for loom and accessory catalogue
— also the nearest agent

Structo Mfg. Co.
FREEPORT, ILL.

and the face resting on soft wood, leather, or rubber. An attractive variation is to make the monogram on a separate piece of a different kind of metal which can be riveted or soldered to the other. If you desire to do so, the hole left by bending down the base piece can be completely covered by a large piece, on which the design is worked or painted, and it can be held in place by tiny rivets made of the same material polished off flush, or hidden in the design. Another variation of the design first illustrated in this article is shown in Illustration No. 4, in which the doorway is cut out, while the tree and border are done in colored lacquers. The cast elephant is fastened to the base with small screws. This makes a pleasing variation.



THIS MODERNISM

(Continued from page 18)

orange; tabby; repeat 4 X; 1-2 orange; 1-3-4 green; 1-5 brown; 1-6 orange; tabby; repeat 4 X; 1-2 brown; 1-3-4 green; 1-5-6 blue; tabby; repeat 4 X; 1-2-3 orange; 1-4 brown; 1-5-6 blue; tabby; repeat 4 X; 1-2-3 orange; 1-4-5 green; 1-6 brown; tabby; repeat 4 X; 1-2 blue; 1-3 brown; 1-4-5 green; 1-6 blue; tabby; repeat 4 X; 1-2 blue; 1-3-4 orange; 1-5 brown; 1-6 blue; tabby; repeat 4 X.

Exhibition and Sale of

HAND WEAVINGS — Colonial and modern style coverlets, luncheon sets, towels, upholstery materials, dress goods, and rugs are included.

This wide selection is the product of the craftsmen members of the Weavers Guild of Boston.

ALSO

Needlepoint designs and wools from the studio of Misses Shaw & Loring.

Yarns and rug patterns from the Bernat "Weavrite" collection.

Hand wrought pewter from the studio of Lester H. Vaughn.



THE PUBLIC IS CORDIALLY INVITED
TO THIS EXHIBITION WHICH
IS BEING HELD AT

140 MARLBORO STREET, BOSTON, MASS.

from MARCH 28 to APRIL 5

Craftsmen will be at work in the exhibition rooms

Burchard Shuttle Craft Studios

468 19th Street

OAKLAND, CALIF.

367 Euclid Avenue

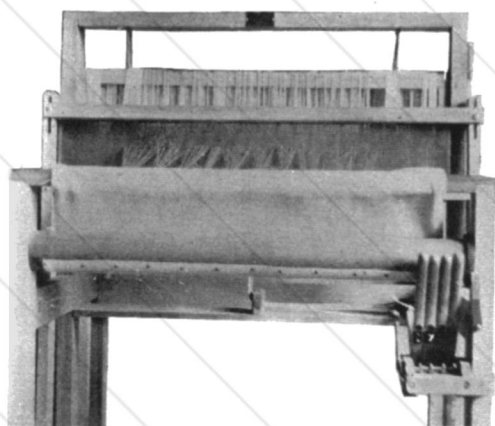

Send for descriptive circular

AGENTS WANTED

WEAVING

YARNS * LOOMS

Patentee and Manufacturer of a unique four harness, hand operated loom, (see cut) that is practical and easy to operate.

BUILT OF HARDWOOD
WEAVES UP TO 25" WIDE
FLOOR SPACE 29" X 32"
WEIGHS LESS THAN 50 POUNDS

Goes thru any ordinary house door, is mechanically correct and weaves fabrics equal to the product of any LOOM.

We carry a good selection of Bernat Weavrite yarns. You will find the choice wide and the prices reasonable. Buying from this stock means a big time saving to weavers and craftsmen on the Pacific Coast. Let us be of service to you.

LOOKING AT THE CRAFTS

(Continued from page 42)

DECORATIVE ARTS EXHIBITION

At the exhibition of the Decorative Arts held in New York, the three weeks preceding Christmas, was shown a very representative selection of American craft work. Pottery, batiks, glassware, embroidery, jewelry, rugs, furniture, silverware, leather work and porcelains were included. Most of the work was good. The pottery group perhaps stands out in quantity; but its standards were not of the highest. It was noticeable, as in almost any exhibition of modern pottery, that the texture of the porcelains does not compare to that of previous periods. In peasant wear this roughness is excusable, but in many of the finer pieces, as shown in this exhibit, the kaolin used should have been better refined to produce a more even texture and more care exercised in the glazes to attain subtle lusters.

Without considering the artistic standards of the exhibition, we are tempted to discuss one of its phases which, if not in some measure remedied, is likely to retard a greater development of crafts, that is, its economic side.

We assume that the craftsman wishes to sell his work, and one glance at the make-up of the catalogue will show that he is no longer working for art's sake only, but also thinking of the sale of his work. Most of the pieces were greatly over-priced. This assertion is based on two facts: first, unlike the artist, the craftsman has the right to duplicate his work, and second, the price of any product should bear some relation to the amount of time spent in its production. A craftsman is not in the same position as the artist; his output is greater; it is not necessary that each of his pieces be individual. Then, too, the craftsman has as his competitors large craft shops and manufacturers. He must recognize that the average buyer cannot afford to pay several hundred dollars for a small table ornament. Nor is it fair to ask a buyer to pay for a product which, though original, may be duplicated, the value of two weeks' work when one day's labor was all that was consumed in production. The craftsman should consider his market. Exorbitant prices limit his expansion. If the craftsman were primarily an artist he need not regard this, but as he is himself an element of industry, he must take this possible outlet into consideration.

From investigation, modern industrialism has definitely convinced itself that the price has a great deal to do with the amount sold. Repeated tests have shown that while 1000 articles are sold for ten cents, 5000 may be sold at five cents, and the greater quantity may enable the manufacturer to cut his costs so as to make more profit by selling the larger number at the lower price. There are

comparatively few people who can afford fifty to a hundred dollars for an ash tray, yet an unlimited number who would not think five dollars out of reach.

The European attitude toward prices is more normal than ours. The craftsman abroad has been able to concentrate his efforts and to work on a larger production scale. He is able to sell all that he produces at reasonable prices and yet at the end of the year finds that he has made a reasonable profit.

The writer does not contend that crafts should be Fordized, but he does believe that the craftsman should make himself amenable to larger scale production methods and thus be in a position to open up a wider sales outlet and be able to keep step with popular trends in tastes.

The solution which occurs to us is for a number of craftsmen to band together to work with a more finished organization toward larger production. Through this consolidation will be derived the benefits of reputation as well as the ability to produce in quantity for a reasonable figure. In Europe people like Rodier, the maker of fabrics, and George Jensen, the Danish silversmith, have accomplished this. Nobody believes for a moment that Mr. Jensen personally does the work on everything he produces, and no one thinks the less of his work if he circulates one or two hundred articles of the same pattern in the whole world than if he made but one specimen of each design. He has been able to build up an organization which will share in the labor, thereby increasing the output, and in turn lower the costs, which means increased profits.

If the American craftsman is to succeed in a financial sense he would do well to follow the European example of moderation in price with greater, though not necessarily excessive, production.

SAKONNET STUDIOS*(Situated on Narragansett Bay)*

PORTSMOUTH, RHODE ISLAND

**SUMMER SCHOOL of
ARTS and CRAFTS**

*under personal direction of BESSIE T. CRAM
Graduate of the Boston Museum of Fine Arts
Master Craftsman of the Boston Society of Arts and Crafts*

Combine summer vacation and art. Intensive courses for one or two weeks if desired. June 1 to October 1.

*For further information write***BESSIE T. CRAM**

175 Prospect Street

Cambridge, Mass.

Standpatters

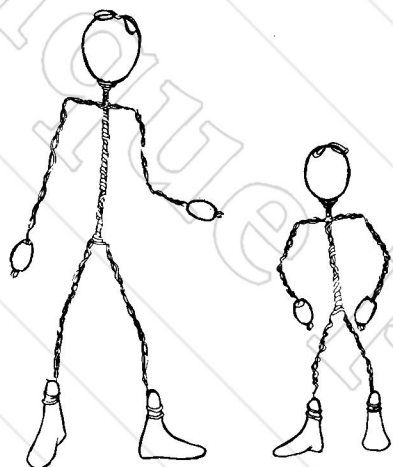

FAMILY of FOUR
with directions for winding

Prepaid, \$1.30

DISCOUNT TO MEMBERS

Send ten cents for catalogue—stimulating material for work with children

INDUSTRIAL ARTS COOPERATIVE SERVICE

519 West 121 Street, New York City



Hand Turned Looms for Hand Weaving

Looms that are practical and ornamental. Have your loom made so that you will be proud to have it in your living room as a beautiful piece of furniture.

SPECIAL FEATURES

Can be taken through the average door without demounting it.

Warp can be released and cloth wound up without leaving your seat.

Easily operated.

Small in size, only 30" x 39" x 50". Will weave 36" material.

Send for further details about turned and plain looms

Made by

Marjorie and Victor Flashman
1135 Curtis Street, Berkeley, California

BAG TOPS

CELLULOID, METAL OR WOOD
Designed Especially for Handwoven Bags

SPECIALS



7" oval, yellow or blue \$1.00

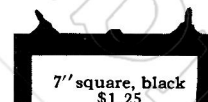

7" square, black \$1.25

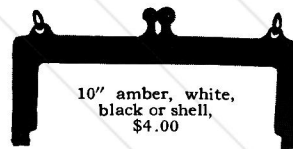

10" amber, white, black or shell, \$4.00

Also tan moiré silk bag lining, 36" wide, excellent quality. \$2.00 yard

CASH WITH ORDER

POSTAGE EXTRA

Send for copy of new price list

MRS. NELLIE SARGENT JOHNSON
12489 Mendota Avenue, Detroit, Michigan

RUMFORD PRESS
CONCORD, N.H.

The SNOW LOOMS

School of Weaving and Crafts

EDITH HUNTINGTON SNOW, *Director*
LAURA L. PEASLEY

WRITE FOR OUR LIST OF
LOOMS AND EQUIPMENT

We use many differing looms, from those of cardboard, or small table looms, to our handsome and craftsmanlike eight-harness loom.

We offer a lesson book of simple and explicit instructions for the beginning weaver, at home, in schools, camps, and hospitals. \$6.00.

Courses in our studio include weaving in interesting variations.

We also teach Jewelry, Leather Work, Basketry, Block Printing, Clay Modeling, Rug Hooking.

48 East 49th Street, New York

The CRAFTSMEN'S GUILD

15 Fayette Street

BOSTON MASSACHUSETTS



¶ A Studio-Shop, devoted to the exhibition and sale of handicrafts. Embroideries, weavings, leather, pottery, enamels, block-printing etchings. ¶ Special orders promptly attended to. Designs for needlework, started pieces with materials, also lessons by appointment. Ensemble bags and scarfs a studio specialty.

JEWELRY AND CRAFT WORKERS SUPPLIES



*METAL WORK TOOLS OF
ALL KINDS. METALS IN
SHEET AND WIRE FORM.
SOLDERS, ENAMELS ...
STONES AND FINDINGS.*

METAL CRAFTS SUPPLY CO.
PROVIDENCE, R. J.

MORAHAN LOOMS *for* HAND WEAVING

Practical Looms, combining beauty of design and fine craftsmanship. Used by designers, professional weavers and public institutions.

FIVE SIZES

*Weavers' Supplies
Bernats Yarns*

ARE CARRIED IN STOCK
IN A WIDE RANGE.
THE PRICES ARE REASONABLE

Send for Circular

MORAHAN LOOMS

711 PICO BLVD. ♣ SANTA MONICA
CALIFORNIA

"HANDCRAFTS"

PATTERNS

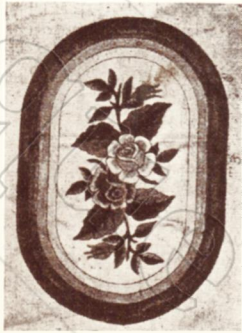

E R 3 20" x 30" \$1.50
One of the New England patterns, water colored on burlap by craftsmen.

on burlap for hooking and on Smyrna canvas for cross-stitch

The collection includes over sixty designs; some are reproductions of Colonial hooked rugs, some are modern in spirit, and others are derived from Chinese and Spanish sources.

The patterns are varied in size and are suitable for rugs, hangings, mats, and furniture covers. They are priced reasonably and Yarn sets in Bernat's Craft Wool can be obtained.

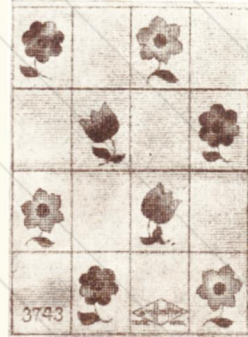

3743 27" x 36" \$2.25
Cross-stitch rug design on Smyrna canvas, an example from the varied selection to be had.

Send for the sixteen-page illustrated booklet and yarn sample card

EMILE BERNAT AND SONS CO. JAMAICA PLAIN, MASS.



For Oriental Rug Craft + + +

WE OFFER

Bernat's Persio Wool

THIS is a three-strand yarn spun of lustrous, long wearing wools and is specially designed for the making of hand-tied knotted rugs, for working on canvas with the automatic needle; and for coarse needlepoint.

It is dyed in a range of fifty gorgeous Persian and Chinese colors. All are fast.

We offer Persio wool in one-ounce skeins packed sixteen to the box and eight-yard skeins packed twelve to the bundle.

Bernat's Persio Wool is the ideal yarn for the newest of arts — Oriental rug craft.

WRITE FOR SAMPLES AND PRICES

EMILE BERNAT & SONS CO.

Jamaica Plain, Massachusetts