

Creative Commons 4.0 NC SA BY FREE DISTRIBUTION ONLY - NOT FOR SALE

Choice Designs in

CROCHET



BOOK 69

www.antiquepatternlibrary.org 2021.11

10 CENTS

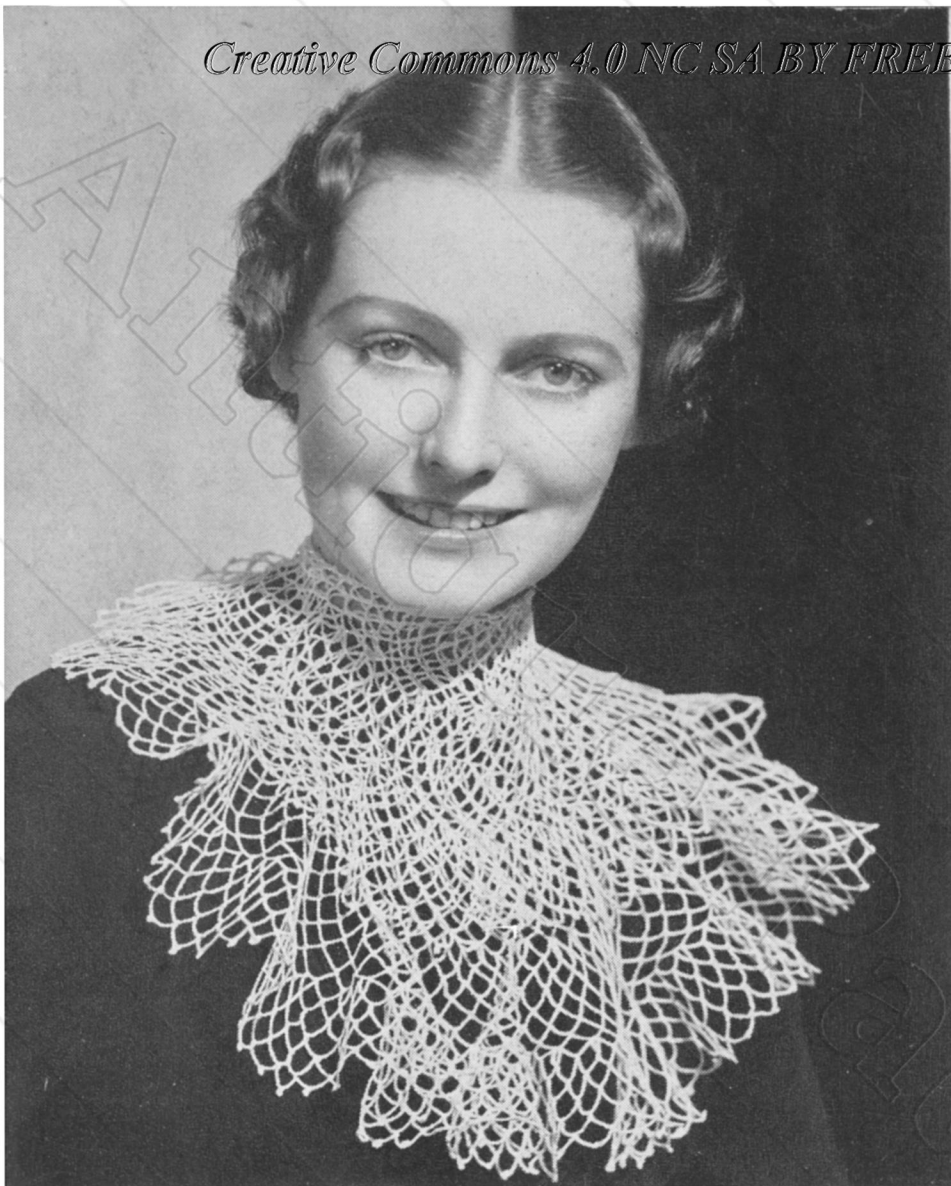

Lace Frill Jabot

No. 2027

Materials: Clark's O.N.T. or J. & P. Coats Mercerized Crochet, 2 balls, size 40, White. Steel crochet hook No. 10.

Ch 12, join with sl st to form ring. **1st rnd:** * Ch 12, s c in ring. Repeat from * 11 more times. **2nd rnd:** Sl st in 6 sts of 1st ch-12 loop. * Ch 10, s c in next loop, and repeat from * around. **3rd and 4th rnds:** * Ch 10, s c in next loop, repeat from * around. **5th rnd:** * Ch 10, s c in next loop, ch 10, s c in same loop, repeat from * around. **6th to 10th rnds incl:** Same as 3rd. **11th rnd:** Same as 5th. **12th to 19th rnds incl:** Same as 3rd. **20th rnd:** Same as 5th. **21st to 26th rnds incl:** Same as 3rd. **27th rnd:** Same as 5th. **28th to 31st rnds incl:** Same as 3rd. **32nd rnd:** * Ch 10, s c in 5th ch from hook (to make picot), ch 5, s c in next loop, and repeat from * around. Fasten off.

Cluny Collar and Cuffs No. 2121

Materials: Clark's O.N.T. Cronita, 3 balls of Ecu. Steel crochet hook No. 7 or 8.

Collar. Ch 161, turn. **1st row:** 1 s c in 2nd ch from hook, 1 s c in each ch to end of ch, ch 2, turn. **2nd, 3rd and 4th rows:** S c in each s c, (always pick up the back loop of each s c throughout these instructions). **5th row:** Increase every 10th s c. (175 s c.) **6th to 20th rows incl:** S c rows increasing as follows: **7th row:** Increase every 8th s c (196 s c). **11th row:** Increase every 9th s c (217 s c). **15th row:** Increase every 9th s c (240 s c). **21st row:** * 1 s c in each of 41 s c, ch 15, skip 9 s c, 1 s c in next s c, ch 15, skip 9 s c. Repeat from * 3 more times, ending row with 1 s c. Ch 2, turn. **22nd row:** * 1 s c in s c, 17 s c under ch-15 loop, 1 s c in s c, 17 s c under next ch-15 loop and repeat from * to end of row, ending with s c in each of remaining s c, ch 2, turn. **23rd row:** S c in each s c to end of row, working last s c of one loop and first s c of the next loop together to decrease 1 s c. **24th row:** 1 s c in s c, * ch 12, skip 8 s c, 1 s c in next s c, ch 17, 1 s c in 8th s c of next loop, skip 8 s c, s c in each of next 41 s c and repeat from * to end of row, ending with s c in each s c, ch 2, turn. **25th row:** * 41 s c, 15 s c under small loops, 19 s c under large loops. Repeat from * to end of row ending with ch-2,

turn. **26th row:** Same as 23rd row. **27th row:** * 1 s c in each of 41 s c, ch 12, 1 s c in center s c of next loop, ch 17, 1 s c in center s c of next loop, ch 17, 1 s c in center s c of next loop, ch 12, skip remaining s c of loop and repeat from * to end of row. **28th row:** S c row making 15 s c under small loops, and 19 s c under large loops. **29th row:** Same as 23rd row. **30th row:** 1 s c in s c, ch 12, s c in center s c of next loop, and continue like 27th row, having 1 large loop extra. **31st row:** Same as 28th row. **32nd to 34th rows incl:** Same as 29th row. Work 4 rows of s c down side with scallop, and work a row of sl sts along opposite end. Sew on 5 snap fasteners.

Cuffs. Ch 91, turn. **1st row:** 1 s c in 2nd ch from hook and in each ch to end. **2nd to 10th rows incl:** 1 s c in each s c, ch 2, turn. **11th row:** S c in each s c, increasing 1 s c in every 9th s c. **12th to 16th rows incl:** S c in each s c. No increase. **17th row:** Increase 1 s c in every 9th s c. **18th row:** S c across. **19th row:** 1 s c in each of 45 s c, ch 12, skip 9 s c, 1 s c in next s c, ch 12, skip 9 s c, 1 s c in each of 45 s c. Continue to work cuff as in collar—the solid part on each side of openwork consisting of 45 s c in each row. Finish off. Sew on snap fasteners. Make another the same.



Cowl Yoke Blouse No. 133

Size 32-34

Materials: Clark's O.N.T. or J. & P. Coats Mercerized Crochet Size 10, 23 balls of color 82 Autumn Glow and 6 balls of Ecu. Steel crochet hook No. 8.

Begin with color 82 ch 94, turn. **1st row:** D c in 4th ch from hook, * ch 3, skip 3 sts of foundation ch, s c in each of next 2, ch 3, skip 3 ch, d c in each of next 2, repeat from * to end of ch, ch 11, turn. **2nd row:** S c in 2nd ch from hook, s c in next ch, ch 3, skip 3 ch, d c in each of next 2 ch, ch 3, skip 3 ch, s c in each of next 2 d c, * ch 3, d c in each of next 2 s c, ch 3, s c in each of next 2 s c. Repeat from * to end of row, ch 3, turn. **3rd row:** D c in 2nd s c, * ch 3, s c in each of next 2 d c, ch 3, d c in each of next 2 s c. Repeat from * to end of row, ch 10 (do not break thread but remove hook and leave free the loop), turn. **4th row:** Attach Ecu to 10th ch of ch-10 just made, s c in same ch, s c in next ch, ch 3, skip 3 ch, s c in each of next 2 ch, ch 3, skip 3 ch, s c in each of next 2 d c thus increasing to shape armhole, * ch 3, s c in each of next 2 s c, ch 3, s c in each of next 2 d c. Repeat from * to end of row. Break off. Do not turn. **5th row:** Pick up color 82 free loop, ch 1, s c in each of first 2 s c, * ch 3, d c in each of next 2 s c, ch 3, s c in each of next 2 s c. Repeat from * to end of row, ch 3, turn. **6th row:** D c in next s c. Repeat from * of 3rd row to end of row, ch 11, turn. **7th row:** S c in 2nd ch from hook, s c in next ch, ch 3, skip 3 ch, d c in each of next 2 ch, ch 3, s c in each of next 2 d c, * ch 3, d c in each of next 2 s c, ch 3, s c in each of next 2 d c. Repeat from * to end of row. Remove hook, as was done at end of 3rd row, and leave loop free. Do not break thread. Turn. **8th row:** Attach Ecu, s c in each of first 2 s c, * ch 3, s c in each of next 2 d c, ch 3, s c in each of next 2 s c, repeat from * to end of row. Break off. Do not turn. **9th row:** Pick up color 82 loop, sl st in 1st s c, ch 3, d c in next s c, * ch 3, s c in each of next 2 s c, ch 3, d c in each of next 2 s c, repeat from * to end of row, ch 11, turn. **10th row:** S c in 2nd ch from hook, s c in next ch, ch 3, skip 3 ch, d c in each of next 2 ch, ch 3, s c in each of next 2 d c, * ch 3, d c in each of next 2 s c, ch 3, s c in each of next 2 d c, repeat from * to end of row, ch 3, turn. **11th row:** D c in 2nd s c, * ch 3, s c in each of next 2 d c, ch 3, d c in each of next 2 s c. Repeat from * to end of row. Remove hook and leave free the color 82 loop, do not break thread, turn. There are no more increases from here on. **12th row:** Attach Ecu. S c in each of first 2 d c, * ch 3, s c in each of next 2 s c, ch 3, s c in each of next 2 d c. Repeat from * to end of row. Break off. **13th row:** Pick up color 82 loop. Continue working pattern evenly until work measures 13½ inches. Then decrease to correspond other side.

Front. Same as Back.

Band. **1st row:** With color 82 make a chain 14 inches long, s c in 2nd ch from hook, s c in next ch, * ch 3, skip 3 ch of foundation ch, d c in each of next 2 ch, ch 3, skip 3 ch, s c in each of next 2 ch. Repeat from * to end of ch, turn. **2nd to 19th rows incl:** Work pattern as in blouse without increasing or decreasing. Make another one of this band.

Yoke. With color 82 make a chain 30 inches long. **1st row:** D c in 4th ch from hook, d c in next ch, * ch 3, skip 3 sts of foundation ch, s c in each of next 2 ch, ch 3, skip 3 ch, d c in each of next 2 ch. Repeat from * to end of ch, ending with 2 d c, ch 1, turn. **2nd row:** S c in each of first 2 d c, ch 3, and continue with pattern ending row with 2 s c over last 2 d c, ch 4, turn. **3rd row:** Skip first 2 s c, s c in each of next 2 d c, continue with pattern across, ending row with 2 s c over 2 d c before 2 s c at end of row. Leave free color 82 loop. Do not break thread. Turn. **4th row:** Attach Ecu, s c in each of first 2 s c, * ch 3, s c in each of next 2 d c, ch 3, s c in each of next 2 s c. Repeat from * across, ending row with s c in each of last 2 s c. Break off. **5th row:** Pick up color 82 loop, sl st in first s c, ch 3, d c in next s c, continue with pattern, ending row with 2 d c in last 2 s c, ch 1, turn. **6th row:** S c in each of first 2 d c, ch 3, d c in each of next 2 s c. Continue with pattern, ending row with s c in each of last d c and ch-3, ch 4, turn. **7th row:** Same as 3rd row. **8th row:** Same as 4th row, ending row with s c in each of last 2 s c before the last loop. Break off. **9th row:** Same as 5th row. **10th row:** Same as 6th row. **11th row:** Same as 3rd row. Break off. **12th row:** Same as 4th row. Break off. **To shape Yoke.** Measure in 5½ inches from each end of work and mark with a pin. Attach color 82 at one of these points. **1st to 5th row incl:** Work pattern evenly across point to next point for 4 rows, then

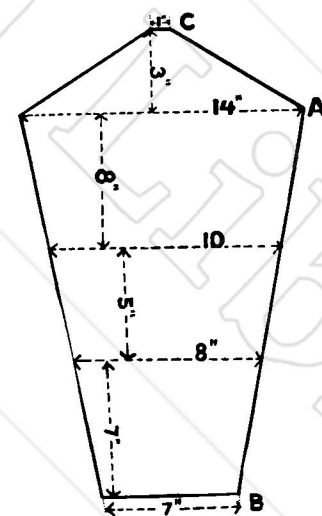

decrease as done previously one-half pattern at beginning and at end of 5th row. **6th to 10 rows incl:** Work pattern evenly. **11th row:** Decrease one-half pattern on each side. **12th to 19th rows incl:** Work pattern evenly. Break off. This completes front of yoke. Attach color 82 at one-half pattern away from the 5½ inch point measured before the center part of yoke was made. **1st and 2nd rows:** Work pattern evenly. **3rd row:** Decrease one-half pattern on each end. **4th row:** Attach Ecu and work even. **5th and 6th rows:** Work even. **7th row:** Decrease one-half pattern at each end. **8th, 9th, and 10th rows:** Work pattern evenly. **11th row:** Decrease one-half pattern at each end. **12th, 13th, and 14th rows:** Work pattern evenly. **15th row:** Decrease one-half pattern at each end. **16th, 17th, and 18th rows:**



Work evenly. **19th row:** Decrease one-half pattern at each end. Work other side to correspond.

Sleeves. To make sleeves, first work out a paper pattern according to the diagram. Begin with color 82 and make chain $2\frac{1}{2}$ inches long starting at A. Turn, and follow pattern making the stripes lengthwise increasing at both ends (A to B and also A to C) and seeing that stripes are straight up and down.

As you work, lay your crocheting on the paper pattern, and make increases or decreases as necessary to shape sleeve.

Sew up side seams of blouse. Sew ends of bands together and sew to blouse. Fit yoke into blouse, having the two ends of foundation ch on yoke meet at the center of blouse. Then sew up sleeve seams and sew into blouse.

Fedora Hat No. 2127

Headsize 21-22

Materials: Clark's O.N.T. Cronita, 3 balls of color 48 Hunter's Green or any Boilfast † color desired. Steel crochet hook No. 5. 1 yd. millinery wire.

Beginning at tip, ch 3, join with sl st to form ring.

1st rnd: 6 s c in ring. **2nd rnd:** 2 s c in each s c.

3rd rnd: * S c in next s c, 2 s c in next s c, repeat

from * around. **4th rnd:** * S c in each of next 2

s c, 2 s c in next, repeat from * around. **5th and**

subsequent rnds: Continue work, making 6 increases to the rnd, placed at equal intervals but not one over

† Trade mark.

another, till work measures 6 inches in diameter. Then work without increasing for 6 inches. If a larger headsize is desired, increase a few s c; if smaller headsize is desired, decrease a few s c. (Work should now measure 9 inches from center.)

Brim. Work 3 inches making 7 increases to the round, not one over another. To make brim hold shape, work last round over a millinery wire.

Band: With thread double, make a chain 43 inches long. Work 4 rows of s c over this ch. Break thread. Plait crown top on head as shown in illustration. Sew band around crown and tie bow in front.





Regal Turban No. 2117

Headsize 21-22

Materials: Clark's O.N.T. (5 balls) or J. & P. Coats (4 balls) Mercerized Crochet, size 10, in any dark Boilfast † color. Steel crochet hook No. 8.

Ch 3, join in a ring. **1st row:** 6 half d c in ring. **2nd row:** 2 half d c in each st. **3rd row:** * 2 half d c in next st, 1 half d c in next st. Repeat from * around. **4th row:** * 2 half d c in next st, 1 half d c in each of next 2 sts. Repeat from * around. Continue to increase 6 sts (or enough to keep work flat) in each round at regular intervals but not one increase over another of previous rnd, until work measures 7½ inches in diameter. Work even, 1 s c in each st for 3 inches. Break off.

† Trade mark.

Band: **1st row:** Ch 28, s c in each ch. Ch 1, turn. **2nd row:** 2 s c in back loop of 1st st, 1 s c in back loop of remaining s c, ch 1, turn. **3rd row:** Skip 1st st, 1 s c in back loop of each s c, 2 s c in last s c, ch 1, turn.

Repeat 2nd and 3rd rows thus having all the decreases on same side and all the increases on the opposite side, until band is required length to fit closely to crown. Sew two ends together.

Place band on hat, having the bottom edge touch the last row of hat for about 2 inches at the seam of band (this is the center back), then slope the band gradually until the bottom edge of band, at center front, touches the first row of s c on hat. Sew in position along the bottom edge leaving top edge loose.

The Co-ed No. 170

Size 16

Materials: Clark's O.N.T. Knitting and Crochet Cotton, 10 balls, color 48 Hunter's Green, or any Boilfast † color desired (4 balls for blouse only). Circular steel knitting needle size 1 for skirt. Set of 6 double pointed steel knitting needles size 10 for blouse. Steel crochet hook No. 5.

Gauge: Skirt:—8 sts equal 1 inch. 11 rows equal 1 inch. Blouse:—6 sts equal 1 inch; 8 rows equal 1 inch.

Skirt. Beginning at bottom, cast on 376 sts on circular needle. Work 3 inches in garter st (k 1 rnd, p 1 rnd). On next k-rnd, * k 92, p 2, repeat from * 3 more times. (These p sts give the appearance of a pleat that is continued to the top of skirt). Repeat this rnd until there are 24 rnds of stockinette. **25th rnd:** Purl across, but decrease 2 sts at each pleat by purling last k st and 1st p st together, then 2nd p st and 1st k st of next group together. **26th rnd:** * K 90, p 2, repeat from * around. **27th rnd:** P around. Work 24 rnds same as 26th rnd, then work a p rnd, decreasing 2 sts on each of the 4 pleats as on 25th rnd. **Next rnd:** * K 88, p 2, repeat from * around. P next rnd. ** Continue making 24 rnds in stockinette, then a p rnd with 2 decreases at each pleat, then 1 k rnd, then a p rnd. Repeat from ** until 5 ridges in all have been made. From here on, work in stockinette, making the 2 decreases at each pleat (8 decreases) every 25th rnd for 8 times. Work straight 10 rnds. Make decreases next rnd, work straight 8 rnds, decrease next rnd, * work straight 4 rnds, decrease next rnd, repeat from * 5 more times. Bind off, but do not break thread. With crochet hook make beading as follows: S c in next

st, ch 5, 1 sl st on wrong side of skirt in 6th rnd from top and 3 sts to the left of s c on edge of skirt, * ch 5, 1 sl st on edge in 6th st from last s c on edge, ch 5, 1 sl st in 6th rnd from top and 3 sts to left of last s c on edge. Repeat from * around. Fasten off and run elastic through beading.

Blouse. Beginning at neck, cast on 124 sts on 4 of the double pointed steel knitting needles. Work rnds of ribbing of k 2, p 2, for $1\frac{1}{8}$ inches. Divide sts on needles as follows:—41 sts on 1st needle, 21 on 2nd, 41 on 3rd, and 21 on 4th. **1st rnd:** P around, casting on 1 st at beginning and at end of each needle (8 sts increased). The increases form lines that give the effect of raglan sleeves. **2nd rnd:** K around. **3rd rnd:** Work same as 1st rnd, this and subsequent odd rnds until there are 107 sts in each larger section and 87 sts in each smaller section. Even rnds are worked same as 2nd rnd.

From here on work back and forth along one 107-st section as follows:—* Work in stockinette for 15 rows, then make a ridge (2 purl rows), repeat from * 3 more times, work 15 rows stockinette, on the last row making 5 decreases (to decrease work 2 sts together). Bind off. Work other 107-st section the same way and bind off.

Sleeves. Work back and forth on one 87-st section in stockinette, decreasing 1 st at end of every 5th row until 62 sts remain. Then work ribbing of k 2, p 2 for 41 rows. Bind off. Make other sleeve to correspond. Sew up sleeve and underarm seams.

On circular needles, pick up the stitches at the lower edge of blouse, and work ribbing of k 2, p 2 for 45 rows. Bind off.

Bellhop Hat No. 2034

Headsize 21-22

Materials: Clark's O.N.T. Cronita, 6 balls, of Color 70 Blue Jewel or any Boilfast † color desired. Steel crochet hook No. 3.

Thread is used double throughout. Ch 4, join with sl st to form ring. **1st rnd:** 6 s c in ring. **2nd rnd:** 2 s c in each st. **3rd and subsequent rnds** (till work measures 9 inches in diameter): Make 6 increases to the rnd distributed so that they do not come over increases of previous rnd. To make an increase, put 2 s c in 1 st. **Next rnd:** Make 1 s c in each st, inserting hook through back loop of stitch only. For the next 20 rnds, decrease 3 sts to each rnd (to decrease a st, insert hook in next st, pull through, insert hook in next st, pull through, then draw thread through all 3 loops at once). Hat should now measure headsize. If not, add as many more rnds as are necessary to make it fit, decreasing 3 sts to the rnd.

† Trade mark.





Debonnaire No. 161

Size 34-36

Materials: Clark's O.N.T. Cronita, 16 balls of color 9 yellow. Steel crochet hooks No. 7 and 3.

Gauge: 9 d c equal 1 inch (sp counts as 2 d c); $3\frac{1}{2}$ rows equal 1 inch.

Blouse Back

Band: Starting at waistband, with No. 7 hook ch 27, turn. **1st row:** 1 s c in 3rd st from hook and s c in each st of ch, ch 1, turn. (25 s c.) **2nd row:** Make 25 s c, picking up the back loops of sts only thus making a row of rib sts. Ch 1 turn. Repeat 2nd row until work measures about 14 inches when stretched across for the back waistband, or adjust to own waist measurement.

Body: Change to No. 3 hook, and make 140 s c across edge of band, ch 1, turn. **2nd row:** Sl st in each of 3 s c, ch 3, 1 dc in each of next 2 sts, ch 2 * skip 2 sts, 1 d c in each of next 6 sts, ch 2, and repeat from * across, working to within 3 sts from end of row and ending with 2 d c. There should be 16 groups of 6-dc and 1 group of 2-dc at each end. Ch 3, turn. **3rd to 21st rows incl:** D c over d c and ch 2 over ch-2, ch 3 to turn. **22nd row:** Work over first 2-dc group and over next 7 groups of 6-dc, turn. **23rd row:** Ch 2, skip next d c, make 1 d c in each of next 5 d c in 1st group, and continue with d c over d c and ch 2 over ch-2. Ch 3, turn. **24th row:** Work back over last row to within 1 st from end. Ch 2, turn. **25th row:** Skip 1st d c, 1 d c in each of next 2 d c, then continue with ch 2 over ch-2 and d c over d c, ch 3, turn. **26th to 30th rows incl:** Continue decreasing 1 st each row at inner edge till at 30th row there will be the 3-dc group and 6 groups of 6-dc. Break thread. Make other side to correspond, starting at inner edge and skipping the 2 center groups (18 sts) leaving these free for yoke to fit in.

Finishing row: Work 1 s c in each st, then 23 s c down slanting side, 1 s c in each of 18 sts across 2 center groups, 23 s c up other slanting side, and finish with 1 s c in each st across.

Yoke: Attach thread to 3rd st from last of 23 s c made down slanting side. Make 1 s c in each of next 3 sts, ch 3, skip first 3 sts of center group, 1 d c in next st, ch 3, skip 3 sts, 1 s c into each of next 3 sts, ch 3, skip 3 sts, 1 d c in next, ch 3, skip 3 sts, 1 s c in each of next 2 sts, skip 1 st, 1 s c into next st, ch 3, turn. **2nd row:** * 1 d c into middle st of 3 s c, ch 3, 1 s c in st directly before next d c, 1 s c in d c, 1 s c in st directly after d c, ch 3, and repeat from * once more, then 1 d c in middle st of 3 s c, ch 3, skip 3 s c of finishing row, 1 s c in next st, ch 3, turn. **3rd row:** * 1 d c in d c, ch 3, 1 s c into each of next 3 s c, ch 3, repeat from * once more, then 1 d c in last d c, ch 3, skip 1 st of finishing row, 1 s c in each of next 3 sts, ch 3, turn. **4th row:** Repeat between *'s of 2nd row 3 times, then skip 1 s c of finishing row, and make 1 s c in each of next 3 s c, ch 3, turn. (These 4 rows form 1 pattern of daisy

lace, and portions between *'s form 1 pattern across.)

5th to 11th rows incl. Continue in pattern, taking up 4 sts of finishing row at end of each row, until there are 5 complete daisy patterns at end of 11th row. All sts on slanting sides will have been worked over, and edge across back is straight. **12th row:** Attach thread to 1st s c of finishing row, * ch 3, skip 2 s c, d c in next, ch 3, skip 1 s c, 1 s c in each of next 3 s c, repeat from * 6 more times which will bring work to 11th daisy pattern row. Continue across 11th row being careful to have patterns match. Work across remainder of finishing edge in same pattern. **13th and 14th rows:** Continue in pattern. **15th row:** Sl st over 1 entire pattern and work across row to within last pattern. Turn. **16th row:** Sl st in first st, work across to within 1 st from end. **17th row:** Sl st over $\frac{1}{2}$ pattern and work across to within $\frac{1}{2}$ pattern from end. Continue decreasing in this way at each end till there are 16 patterns in the row. Then work even till there are 39 rows of daisy lace.

To Shape Shoulders, 40th row: Sl over $\frac{1}{2}$ pattern, work across to within last $\frac{1}{2}$ pattern, turn. **41st row:** Sl st over 1 pattern, and work across to within 1 pattern from end, turn. **42nd to 45th rows incl:** Like 41st row. Break thread and fasten.

Blouse Front

Band: Start band same as for back, making buttonholes after the 3rd row. **4th to 7th rows incl:** Make 3 s c, ch 1, turn. Work 4 rows over these 3 s c, fasten thread. Skip 1 st of 3rd row, attach thread to next, and work over 8 sts, 4 rows of s c. Skip 1 st of 3rd row, and work 4 rows of s c over next 8 sts. Then skip 1 st of 3rd row, and work 4 rows of s c over last 3 sts. Ch. 1, turn. **8th row:** Make 3 s c, ch 1, 8 s c, ch 1, 8 s c, ch 1, 3 s c, ch 1, turn. Continue making 25 s c to the row as for back band, making buttonholes on other end to correspond.

Body: Change to No. 3 hook, and make 144 s c across edge of band, ch 1, turn. Work same as for back, having 4 d c at each end instead of 2-dc, and in shaping for yoke, make 45 s c across for finishing row instead of 43 s c.

Yoke: **1st to 24th rows incl:** Same as for back, excepting on 16th row, sl st in first 3 sts and work across to within 3 sts from end. **25th row:** To shape neck, find exact center, and work till that center, turn. **26th to 39th rows incl:** Decrease $\frac{1}{2}$ pattern at neck edge every other row, working other side straight. **40th to 45th rows incl:** Shape shoulder line as for back. Work other side of front to correspond.

Sleeves

Ch 80 and make 6 rows of s c for band. **7th row:** Make 13 patterns across row. **8th to 25th rows incl:**



Work straight in pattern. **26th and 27th rows:** To decrease for armhole, sl st over 1 complete pattern and work across to within 1 pattern from end, turn. **28th row:** Decrease $\frac{1}{2}$ pattern at each end. Continue decreasing $\frac{1}{2}$ pattern at each end until only 5 patterns remain. Make other sleeve to correspond. Press all pieces, then sew shoulder seams. Sew sleeves into armholes, and join sleeve and underarm seams.

Neckband: With No. 7 hook, holding right side of blouse towards you, fasten thread to upper right shoulder seam. Make s c around neck, spacing sts so that work will not pull. Continue with s c for 4 rows, making 5 decreases to the row (to make a decrease, skip 1 st, s c in next). Cover buttons and sew on to correspond with bottonholes.

Skirt

Front: With No. 3 hook, ch 196, 1 s c in 3rd st from hook and in each st of ch (194 s c). Work 20 rows of s c, then ch 3, turn. **21st row:** 1 d c in each of next 5 sts, * ch 2, skip 2 sts, 1 d c in each of next 11, repeat from * 13 more times, ch 2, skip 2 sts, 1 d c in each of next 5 sts, ch 3, turn. Work next 25 rows evenly, making d c over d c and ch 2 over ch-2. **47th to 120th rows incl:** Decrease 1 st at beginning and 1 st at end of each row.

Waist should measure about 31 inches. If longer skirt is desired, add more rows without decreasing.

Back: Same as front. Sew together side seams. With No. 3 hook make 1 round of s c around top of waist. At end of rnd, * ch 5, skip 4 s c, 1 tr into next, repeat from * around. These spaces are for elastic. Press skirt and block to desired length.

Knot Stitch Frill Collar and Jabot No. 2106

Materials: Clark's O.N.T. or J. & P. Coats Mercerized Crochet, size 10, White, 2 balls. Steel crochet hook No. 9.

Collar: Ch 150, turn. **1st row:** * Make a knot st (draw loop on hook out $\frac{1}{4}$ inch, draw thread through, making a ch st of it; put hook between loop and single thread of this ch and make a tight s c). Make another knot st, skip 1 st of ch, s c in next. Repeat from * to end of row, ch 6, turn. **2nd row:** Make 1 knot st, s c in s c between first 2 knots sts of previous row, * 2 knot sts, s c in s c between 2 following knot sts, repeat from * ending with 1 s c in s c between last pair of knot sts, 1 knot st, 1 tr tr at base of 1st knot st of previous row. Turn. **3rd row:** 2 knot sts, s c in s c between 2nd and 3rd knot sts of previous row, * 2 knot sts,

s c in s c between 2 following knot sts, repeat from * to end of row. Ch 6, turn. **4th to 8th rows incl:** Repeat 2nd and 3rd rows. Fasten off.

Jabot: Ch 54 and work 8 rows of knot sts as for collar. Make another piece the same way, only slightly larger starting with ch 60.

To Join Jabot Pieces To Collar, attach thread to 1st st of foundation ch of larger jabot piece, ch 22, join with sl st to 1st st of foundation ch of smaller jabot piece, ch 22, join to 51st ch st of collar. Be careful to have all the ch-22's lie on the wrong side of work. Make a similar joining at other end of foundation chains of all three pieces, and as many more joinings between these two as are necessary to keep jabots from sagging.

Starch and press into shape. Fasten collar at back with a button.

Peter Pan Frill No. 2115

Materials: Clark's O.N.T. (2 balls) or J. & P. Coats (1 ball) Mercerized Crochet, size 50, White. Steel crochet hook No. 10 or 11. A small white button.

Collar: Starting at neck, ch 250 (to measure about $15\frac{1}{2}$ inches), turn. **1st row:** 1 d c in 5th ch from hook, * ch 1 skip 1 ch, 1 d c in next ch, repeat from * to end of row, making 4 increases at equal intervals. (To increase, make 2 d c in same ch, with ch-1 between.) Ch 5, turn. (This forms the heading row.) **2nd row:** * 1 s c in 2nd d c from hook, ch 5, and repeat from * to end of row, ch 9, turn. **3rd row:** Same as 2nd row, making s c's in 3rd ch of ch-5, ch 9, turn. **4th, 5th and 6th rows:** Make ch-7 loops across. Ch 11, turn. **7th to 10th rows incl:** Make ch-9 loops across. Ch 13, turn. **11th to 14th rows incl:** Make ch-11 loops across. Ch 15, turn. At end of 14th row, do not break off thread but make a row of heading along side of collar. Make another row of heading on opposite side, and also 3 of ch-9 loops for buttonholes. Make 3 crochet buttons and sew on opposite side to correspond.

Jabot: Ch 150 (to measure about 9 inches), turn. **1st row:** 1 s c in 5th ch from hook, * ch 5, skip 4 ch, 1 s c in next ch, repeat from * to end of row. **2nd, 3rd and 4th rows:** Same as 3rd row of collar. **5th, 6th and 7th rows:** Same as 4th row of collar. **8th, 9th and 10th rows:** Same as 6th row of collar. **11th, 12th and 13th rows:** Same as 11th row of collar. **14th, 15th and 16th rows:** Make ch-13 loops across. Ch 17, turn. **17th, 18th and 19th rows:** Make ch-15 loops across. Ch 19, turn. **20th, 21st and 22nd rows:** Make ch-17 loops across. Ch 21, turn. **23rd, 24th and 25th rows:** Make ch-19 loops across. Ch 23, turn. Break off thread. Fold Jabot into a box pleat at narrow end. Turn edges on each side of pleat under for 2 or 3 inches and holding pleat in place, finish with one row of heading as in collar and break off thread. Place center of collar on top of center of Jabot, and sew both edges together on wrong side. Starch stiffly and pleat in place. Fasten collar with button at back.







Waistcoat No. 141

Size 34-36

Materials: Clark's O.N.T. Knitting and Crochet Cotton, 6 balls of White or Ecrú, for waistcoat and scarf. 1 ball of color 55A Dk. Navy for trimming scarf. 1 pair knitting pins No. 4. Steel crochet hook No. 4.

Gauge: 13 sts to 2 inches (including the fancy st). 7 rows to 1 inch.

The entire jacket is worked with 2 strands of cotton.

Back: Cast on 79 sts and knit in garter st for 7 rows, making 10 increases on the 8th row (in about every 8th st)—89 sts. **1st row of pattern:** K 3, * k 1 wrapping the thread 3 times around the needle instead of the usual once (this will make a loose set), k 1, k 1 with the thread 3 times over the needle, k 5, repeat from * ending row with k 3. **2nd row:** Purl all the sts except the loose sts which are slipped off as 1 long st. **3rd row:** Knit all the sts except the loose sts which this time are twisted to the left as they are slipped off. **4th row:** Purl all the sts. In purling the loose sts, pick up the back loop instead of the front, thus keeping the twist. Work in pattern for 2 inches. Increase 1 st in 2nd st from beginning and end in next row and every 12th row for 4 times. Work until piece measures 9½ inches. At beginning of next 2 rows, bind off for armhole 4 sts, then 2 sts at beginning and end of every other knitted row for 2 times and 1 st at beginning and end of every knitted row 3 times. Work even on these 77 sts until armhole measures 6½ inches. Bind off 6 sts at beginning of next 4 rows, and 7 sts on next 4 rows. Bind off the remaining 25 sts for neck.

Lining for Pocket: It is wise to have this made, ready to be worked into the front. Cast on 21 sts and k in stockinette st for 3 inches. Start pattern with k 1 and ending with k 1. Work 5 rows and slip sts on an extra needle.

Left Front: Cast on 3 sts, k plain in garter st, working front edge even, and casting on at other edge 4 sts twice, 6 sts once, 8 sts twice, 9 sts once, 11 sts once (53 sts). Work 7 rows, then make 6 increases on 8th row about every 8th st (59 sts). The first 8 sts of front edge are always worked in garter st, the balance in pattern. Work the increases at side seam as in back, to armhole. After 20 rows have been worked in the pattern, on first row of next pattern work 19 sts in pattern, 21 sts in garter st, and the remaining sts in pattern and border. For 7 more rows, work the 21 sts in garter st for pocket border. On next row, bind off the 21 sts and work across. On the row back, work to the pocket, work the pocket lining sts in pattern, and continue across. Work to the armhole (9½ inches), then bind off 5 sts twice, 2 sts twice, and 1 st twice. Work even until there are 65 ridges on front edge from the bottom point. From front edge, bind off 3 sts for 3 times, then 2 sts for 3 times. Now begin to slope shoulders as in back, continuing to bind off 2 sts at front edge for 3 more times.

Right Front: This is worked the same as left front, except that the 8 sts of garter st for front border are worked first, then pattern begins with k 5 and ends with k 3. When there are 17 ridges on front edge from bottom point, make the first buttonhole

by knitting 3 sts, binding off 3 sts, and working across as usual. On the next row back, cast on 3 sts where the 3 were bound off, and knit last 3 sts. Make 6 more buttonholes with 5 ridges between. When it is time to make the pocket, work 20 sts from front edge, then the 21 sts in garter st, and 19 in pattern, and work to correspond.

Sleeves: Cast on 49 sts and knit 8 rows in garter st. Start pattern by beginning with k 3, and ending with k 3. Work in pattern for 10 rows, then increase 1st at both ends of next row and every 10th row for 5 times, start a new pattern at both ends by k 2, loose st, k 5, completing it when you have 4 sts. Increase in every 8th row for 4 times, and every 6th row for 3 times. Work even until piece measures 18 inches through center of length. Bind off 5 sts at beginning of next 2 rows. Decrease 1 st at beginning and end of every knitted row until there are 29 sts on needle. Then decrease on every row at both ends until 15 sts are left to be bound off.

Collar: Cast on 18 sts, and work in garter st for 59 ridges, and bind off. Attach to body, leaving free the 9 bound off sts of front edge.

Scarf. Use thread double. With white cast on 25 sts. 1st to 10th rows incl: K in garter st (5 ridges). 1st row of pattern: K 3, * k 1 with the thread 3 times over needle (this makes a loose st), k 1, k 1 with thread 3 times over needle, k 5, repeat from * ending row with k 3. 2nd and subsequent rows: Work in pattern as for back, but always k the first 3 and the last 3 sts for every row—thus having worked the edges in garter st. When work measures 28 inches or any length desired, k plain for 10 rows to correspond with other end. Then bind off. With Dk. Navy and crochet hook, fasten thread in 28th st from corner on the long side. Work s c in each of next 11 sts, d c in each of next 9 sts, tr in each of next 7 sts, 5 tr in corner st, tr in each st across short end, 5 tr in corner st and 7 tr, 9 d c 11 s c, on sides as done before. Work other end to correspond.

Eton Tailored Collar Set No. 289

Materials: Clark's O.N.T. or J. & P. Coats Mercerized Crochet, size 10, White, 2 balls. Steel crochet hooks No. 5 and No. 2. 6 glass buttons.

With No. 5 hook, ch 129, turn. 1st row: D c in 4th ch from hook, d c in each st of ch, making 6 increases at equal intervals. (To make an increase, work 2 d c in 1 st.) Ch 3, turn.

2nd to 8th rows incl: D c in each d c, with 6 increases to each row, divided equally but not placed one over another. Ch 3, turn. 9th row: Change to No. 2 hook. Skip 2 sts, * 4 d c in next, ch 1, 4 d c

in same place, skip 5 sts and repeat from * to end of row. Turn. (These are shell sts.) 10th and 11th rows: Work shell over shell.

Cuffs: With No. 5 hook, ch 55, turn. Work same as collar, making only 2 increases to each d c row for 8 rows, then make 3 rows of shell sts. Sew up cuffs, leaving opening at wrist. Sew on buttons, then make ch loops worked over with s c's for button holes. Sew buttons on collar as in illustration, making ch loops worked with s c as for cuffs.

To make set larger, add sts to foundation ch for desired size.





Shirtwaist Blouse No. 174

Size 34-36

Materials: Clark's O.N.T. Knitting and Crochet Cotton, 5 balls of color 61-A Dk. Ecreu and 1 ball of color 82 Autumn Glow for trimming. Steel Crochet hook No. 3 for star sts and No. 6 for remainder.
Gauge: 4 star sts to 1 inch. 3 rows to 1 inch.

Waistband: With Dk. Ecreu, ch 31, turn. **1st row:** 1 s c in 2nd ch from hook, 1 s c in each st of ch. Ch 1, turn. **2nd row:** 1 s c in back loop of each st. Ch 1, turn. Repeat 2nd row until there are 48 ridges (12 inches). Make another band the same as the first one. Do not break off thread after making 2nd band, but continue with **Blouse** working in rnds along side of one band and then along side of other band as follows: **1st rnd:** Ch 3, insert hook in 2nd ch from hook, draw out a loop, insert hook in 3rd ch, draw out a loop, insert hook in place where ch-3 started, draw out a loop, insert hook under turning ch of next row, draw out a loop, thread over and draw through all 5 loops on hook, ch 1 (a star st). Then insert hook through single loop at back of ch-1 just made, draw loop through, insert hook under outside thread of star st just made, draw through, insert hook in next st, draw loop through, skip next row, insert hook under turning ch-1 of next row, draw through, then thread over and draw through all five loops at once, ch 1, (another star st). * Continue working 1 star st under each turning ch-1 along the side of band (skipping the rows between the ch-1's) until there are 10 star sts, make 11th star st in row before next turning ch-1, repeat from * 3 more times, then make 1 star st under each ch-1. There should be 52 star sts along side of band. Do not break thread, but continue along side of other band making 52 star sts. Do not turn work. **2nd to 25th rnds incl:** Make 1 star st in each star of previous rnd. Then

start to shape armholes. Work across back only, breaking thread at end of each row and attaching to beginning in order to have sts run in same direction. After 25th rnd, sl st over 2 star sts, ch 3, and make 1 star st in each of next 48 star sts. Fasten and break thread. **27th row:** Attach to beginning of 26th row, sl st over 1 star st, and make 1 star st in each of next 46 star sts. Fasten and break thread. **28th row:** Attach to beginning of 27th row, sl st over 1 star st, and make 1 star st in each of next 44 star sts. **29th to 46th rows incl:** Work over 44 sts evenly. Then shape shoulder and neck. Attach thread to 9th st of previous row, make 1 star st in 9th and following 4 sts. Break thread, skip next 18 sts. Attach thread to 19th st and make 1 star st in 19th st and in following 4 sts. Break thread and attach to front. Work 6 rows same as for back.

32nd row: Work to center of row (22 star sts). Break thread. **33rd to 38th rows incl:** Attach to beginning of previous row and work over 22 star sts. Break thread. **39th to 47th rows incl:** Attach thread to beginning of previous row and work star sts to within 1 st from end, thus shaping the neck. There will be 13 star sts in the 46th row. **48th row:** Attach thread to 9th star st and make 5 star sts. Make other side of front to correspond. **Sleeves:** **Band.** With Dk. Ecreu ch 14, turn. **1st row:** S c in second ch from hook, s c in each st of ch, ch 1, turn. **2nd row:** 1 s c in only back loop of each st, ch 1, turn. Repeat 2nd row till band is 10 inches long. Then make 43 star sts along side of band. Do not turn but work in rnds. **2nd rnd:** 1 star st in each st of previous rnd. Increase 1 star st at end of rnd by working an extra star st in the stitch before 1st star of this rnd. (44 star sts.) **3rd rnd:** Work evenly. **4th rnd:** Increase 1 star st at end of rnd. (45 star sts.) **5th rnd:** Work evenly. **6th rnd:** Increase 1

star st at end (46 star sts). **7th rnd:** Work evenly. Break thread. **8th rnd:** Attach to 3rd star st of previous rnd and make star sts to within 2 from end (42 star sts). Break thread. Repeat 8th rnd until 8 star sts are left. Make another sleeve to correspond. Sew together the 1st and last rows of the bands. Sew shoulder and underarm seams.

Collar: Attach Dk. Ecru to left neck edge at 40th row of left front, and with wrong side of work towards you, make 43 star sts up the neck, across the back and down other neck edge, ending at 40th row of right front. Work 4 more rows of star sts. Break thread. Attach Autumn Glow to where collar was started. Work s c across edge of collar, then make 2 s c in each star st across last row of collar, then work s c across other edge. Ch 1, turn. Work 10 more rows of s c into only back loops of sts, making 3 s c in each corner st. Sew Autumn Glow edges

along neck. **Pockets:** With Dk. Ecru ch 27, turn. Work 12 star sts on ch for 6 rows, breaking thread at end of each row and starting at beginning to keep work in same direction. Then work 7 rows of s c with Autumn Glow, picking up only back loops. Make another pocket and sew both pockets to blouse in the position illustrated. **Front Trimming:** With Autumn Glow, ch 81, turn. **1st rnd:** S c in 2nd ch from hook, s c in each st of ch, in last ch make 3 s c, do not turn but continue along other side of ch, making 3 s c in last ch. Join with sl st to 1st s c. Ch 1, turn. **2nd to 7th rnds incl:** 1 s c in each s c, and 3 s c at each of the 2 end s c's. Join each rnd with sl st and ch 1 to turn. Baste this piece down the front of the blouse. Then sew on 5 buttons. Sew 2 buttons at each end of back waistband, and make 2 ch-10 loops at each end of front waistband for buttonholes.

Chain Link Belt and Pocket Set No. 2087

Materials: Clark's O.N.T. Knitting and Crochet Cotton, 1 ball each of White and color 26 Nile Green. Steel crochet hook No. 6.

This set is very effective with a simple fabric blouse as in illustration.

Belt. Rings. With Green, ch 25, join with sl st to form ring. **1st rnd:** Make 50 s c in ring. **2nd to 5th rnds incl:** S c in each s c. This completes a ring. Break off.

To make second ring, ch 25, draw end through previous ring (to link second ring through first one), and then join with sl st to 1st st of ch to form ring. Make 50 s c in this ring, and complete it as for previous ring. Break off.

To make belt, attach White to where thread was broken off on ring, and make 1 s c in each of next 12 s c of ring (picking up only the back loop of each s c of ring), ch 1 turn. **2nd and 5th rows incl:** Make s c in each s c across. Ch 1, turn. **6th row:** * S c in next s c, then insert hook at base of next s c, draw loop through, and work off these 2 loops as for a s c, and repeat from * across. Ch 1, turn. **7th and subsequent rows:** * Work 5 rows of s c as in 2nd row. Then repeat 6th row, and repeat from * until belt (not counting the rings) measures 6 inches less than desired size of belt. Break off White. With Green, make 2 more rings (linked together as before) and sew one of these rings to end of belt to correspond with opposite end.

Buttons. With White, ch 3, and make 10 s c in 2nd ch. **2nd rnd:** 2 s c in each s c. **3rd, 4th and 5th rnds:** 1 s c in each s c. At end of 5th rnd, stuff button with cotton. **6th and 7th rnds:** 1 s c in every other s c, thus decreasing. **8th rnd:** Sl st in every st. Break off.

Sew button to edge of outer ring at one end of belt. The space of corresponding ring on opposite end of belt will serve the purpose of a buttonhole. Tack rings together in position at the center so that they do not move.

Pocket. Rings. With Green make 2 rings (linked as in belt). Then make a third ring linked to the two rings as follows: ch 25, draw end through both rings and then join with sl st to first st of ch and form ring. Make 50 s c in this ring and complete

as before. Break off. Tack rings together in position at the center so that they do not move.

Outer Band of Pocket. 1st rnd: Attach Green to the 4th s c on the upward slope of one ring, and * make 1 s c in each of next 4 s c, 2 s c in next s c, repeat from * around first ring, until the 3rd s c from point where the rings touch. Ch 8, s c in the 4th s c on the upward slope of next ring, and work over this and the next ring as the first ring. Break off. **2nd rnd:** Attach White, and work 1 s c in each s c and in each st of ch-8. **3rd to 6th rnds incl:** S c in each s c, increasing whenever necessary to keep work perfectly flat. (To increase, make 2 s c in 1 st.) Break off.

Button. Like button for belt.

Button Cord. With White, ch 20, break off.

Fasten both ends of each ch-20 to the button. Fasten folded end of ch to center of the pocket.



Dolman Two-Piece Dress No. 177

Size 34-36

Materials: Clark's O.N.T. Cronita, 6 balls of White and 9 balls of color 9 Yellow (for Blouse); and 15 balls of color 130 Seal Brown (for Skirt). Steel crochet hook No. 6. $\frac{1}{2}$ yd. black grosgrain ribbon, 1 inch wide. 3 hooks and eyes.

Gauge: 8 stitches make 1 inch. 2 rows make $\frac{7}{8}$ inch.
Blouse Front. Start at bottom. With White, ch 143, turn. **1st row:** Insert hook in 2nd ch from hook and draw out a loop, insert hook in next ch and draw out a loop, insert hook in next ch and draw out a loop, (5 loops on hook), thread over and take off 2 loops at a time until all loops have been worked off (1 afghan bar completed). * Draw out 3 loops along left side of bar just made (by inserting hook in each of the first 3 loops drawn out for previous bar), insert hook in next st of foundation ch, draw out a loop, thread over, and work off loops on hook 2 at a time. Repeat from * to end of ch (139 bars). Work should measure $17\frac{1}{2}$ inches. Ch 4, turn. **2nd row:** Insert hook in 2nd ch from hook and draw out a loop, insert hook in next ch and draw out a loop, insert hook in next ch and draw out a loop, insert hook in 1st st of previous row and draw out a loop. Thread over and work off all loops on hook. Continue making 1 bar in each bar of previous row to within 2 bars from end. Then decrease 1 bar as follows: Draw out the 3 loops along bar just made, then draw out 1 loop through each of last 2 bars, thread over, pull through 3 loops, then pull through 2 loops at a time until all loops have been worked off. Ch 4, turn. **3rd and 4th rows:** Same as 2nd row, excepting no decrease at end. **5th row:** Same as 2nd row. **6th to 17 rows incl:** Repeat rows 3, 4 and 5 in order. After 17th row, 6 bars will have been decreased. Work next 3 rows straight. **21st to 26th rows incl:** Increase 1 bar at end of each row (to increase work 2 bars in 1 st). **27th to 29th rows incl:** Work straight. Now start to shape armhole.

30th row: Sl st over 6 bars, ch 1, s c in each of next 6 bars, ch 2, insert hook in 2nd ch from hook and pull through a loop, pull through another loop at side of s c just made, pull a loop through next bar, then work off loops 2 at a time (a 2-loop bar). Make 5 more 2-loop bars, ch 2, and continue with the usual 3-loop bars to within 18 bars from other end, then work 6 2-loop bars, 6 s c, and 6 sl st. Break thread. **31st row:** Attach White to 25th bar of row, ch 4, and work 53 bars (to within 25 bars from other end). **32nd to 48th rows incl:** Decrease 1 bar at end of each row. Break thread.

Back. Start at bottom with ch 139, with White. **1st row:** 135 bars. Work next 3 rows straight.

5th to 18 rows incl: Decrease 1 bar at end of each row. Work next 2 rows straight. **21st to 26th rows:** Increase 1 bar at end of each row. Work next 3 rows straight. Then start to shape armhole. **30th row:** same as 30th row of front. Break off. **31st row:** Attach White at 22nd bar, make 47 bars, which should bring work to within 22 bars from other end. **32nd to 42nd rows incl:** Decrease 1 bar at end of each row. **43rd to 48th rows incl:** Decrease 1 bar at beginning and 1 bar at end of each row.

Sleeve. With Yellow, ch 58, turn. **1st row:** 54 bars. **2nd to 8th rows incl:** Work straight. **9th to 32nd rows incl:** Increase 1 bar at beginning and 1 bar at end of each row. **33rd and 34th rows:** Increase 2 bars at beginning and 2 bars at end. Break thread. **35th row:** Ch 9, make 3 bars in 1st bar of previous row, continue to end of row, making 3 bars in last bar. Ch 13, turn. **36th row:** Make 9 bars over ch-13, 1 bar in each bar across previous row, 1 bar in each st of ch-9. Work 9 rows straight (132 bars). **46th and 47th rows:** Decrease 2 bars at beginning and 2 bars at end of each row. **48th to 62nd rows incl:** Decrease 2 bars at beginning, 2 bars at center, and 2 bars at end of each row. Make another sleeve to correspond. **Pockets.** With Yellow, ch 33. **1st row:** 29 bars, Work 7 more rows straight. Break thread. Make another pocket. **Belt.** With Yellow ch 24. **1st row:** 20 bars, work straight till length desired. Sew underarm seams and then sew in sleeves. Sew on pockets as illustrated.

Skirt. Beginning at waist, chain about 204 sts (to measure 27 inches). **1st row:** Work same as 1st row of blouse front. Break thread. **2nd to 15th rows incl:** Attach thread to 1st st at beginning of row, ch 4, and continue making 1 bar in each st of previous row, making 3 increases at equal distances apart (to increase, make 2 bars in 1 st), placing increases so that they do not come over those of previous row, but are equally distributed along work. Break thread at end of each row and attach it at beginning of same row. At end of 15th row, do not break thread, but join with sl st to 8th st from beginning of row (thus overlapping the 8 last sts of this row over the first 8 sts for placket). Turn. Sl st through both thicknesses of these 8 overlapped sts, ch 4, turn. **16th rnd:** Make 1 bar in each st of previous row, making 3 increases as in 2nd row. Join last bar to 1st bar with sl st, ch 4. **17th and subsequent rnds:** Repeat 16th rnd until work measures 22 inches in all.

From here on work without increasing until skirt is desired length.

Sew ribbon along both sides of placket on inside, and fasten placket with hooks and eyes.



Dotted Crocheted Cardigan No. 182

Size 32-34

Materials: J. & P. Coats (11 balls) or Clark's O.N.T. (13 balls) Mercerized Crochet, size 20, White or Ecru. Steel crochet hook No. 10. 6 buttons.

Gauge: 4 sps; 7 rows equal 1 inch. 12 dc; 5 rows equal 1 inch.

Back: Begin with ch 186, 1 s c in 6th ch from hook. *Ch 3, skip 2 ch, 1 s c in next ch, repeat from * to end of row (61 sps), ch 5 turn. **2nd row:** 1 s c in first sp, * ch 3, 1 s c in next sp, repeat from * to end of row, ch 5 turn. **3rd, 4th and 5th rows:** Repeat 2nd row. **6th row:** 1 s c in first sp, ch 3, 1 s c in next sp, * 3 d c in next sp, 1 d c in next s c, 3 d c in next sp, 1 s c in next sp, 6 sps, repeat from * ending row with 2 sps, ch 5 turn. **7th row:** 1 s c in first sp, ch 3, 1 s c in next sp, * 1 d c in s c of previous row, 1 d c in each of the next 7 d c, 1 d c in s c of previous row (9 d c in all) 1 s c in sp, 5 sps, repeat from * ending row with 1 sp, ch 5, turn. **8th row:** 1 s c in first sp, * ch 3, skip 1 s c, 1 s c in first d c, 1 d c in each of the next 7 d c, 1 s c in next d c, 5 sps, repeat from * ending row with 2 sps, ch 5, turn. **9th row:** 1 s c in first sp, ch 3, 1 s c in next sp, * ch 3, 1 s c in 2nd d c of previous row, ch 3, skip 1 d c, 1 s c in next d c, ch 3, skip 1 d c, 1 s c in next d c, ch 3, 1 s c in next sp, 5 sps, repeat from * ending row with 1 sp, ch 5, turn. **10th to 14th rows incl:** Work rows of sps, ch 5, turn. **15th row:** 1 s c in first sp, 6 sps, * 3 d c in next sp, 1 d c in s c, 3 d c in next sp, 1 s c in next sp, 6 sps, repeat from * to end of row, ch 5, turn. **16th row:** 1 s c in first sp, * 5 sps, 1 d c in s c of previous row, 1 d c in each of the next 7 d c, 1 d c in s c of previous row 1 s c in sp, repeat from * ending row with 6 sps, ch 5 turn. **17th row:** 1 s c in first sp, * 5 sps, ch 3, skip 1 s c, 1 s c in first d c, 1 d c in each of the next 7 d c, 1 s c in next d c, repeat from * ending row with 6 sps, ch 5, turn. **18th row:** 1 s c in first sp, * 5 sps, ch 3, 1 s c in 2nd d c of previous row, ch 3, skip 1 d c, 1 s c in next d c, ch 3, skip 1 d c, 1 s c in next d c, ch 3, 1 s c in sp, repeat from * ending row with 6 sps, ch 5, turn. Work 5 rows of sps. Repeat from 6th row 4 times more. Repeat 6th, 7th and 8th rows once more.

To Shape Armhole: Sl st along to 4th d c, ch 3, skip 1 d c, 1 s c in next d c, work same as 18th row, ending row with ch 3, 1 s c in 4th d c of last group of d c's of previous row, ch 3, turn. Continue working pattern decreasing on each row until there are

50 sps. (To decrease turn with ch 3 instead of ch 5 and omit sp of ch 3 on next row.) **Next row:** ch 3, 1 s c in first sp, * 3 d c in next sp, 1 d c in s c, 3 d c in next sp, 1 s c in next sp, 6 sps, repeat from * ending row with a full group of d c's, 1 s c in next sp. **Following row:** Sl st to 2nd d c, ch 3, 1 d c in each of the next 5 d c, 1 s c in next sp, work same as 16th row, ending row with a full group of d c's. **Next row:** Sl st in 2nd d c, ch 3, 1 d c in each of the next 5 d c, 1 s c in next d c, work same as 17th row, ending row with 5 d c, ch 3, turn. **Following row:** Skip 1 d c, 1 s c in next d c, ch 3, skip 1 d c, 1 s c in next d c, work same as 18th row, working last s c in 4th d c of last group of d c's, ch 3, turn (46 sps). Continue working pattern, decreasing on each row until there are 43 sps. Work 26 rows without decreasing. Decrease 2 sps at end of next 3 rows, ch 3, turn. Work 9 sps, ch 3, turn. * 7 sps, ch 3, turn, 5 sps, ch 3, turn. 3 sps, ch 3, turn. 1 sp, break off. Skip 5 sps for back of neck, attach thread to next ch-3 after 2nd bl and repeat from * once more.

Front: Begin with ch 105. Work same as for back (34 sps) until armhole is reached.

To Shape Armhole: Sl st along to 4th d c, work to end of row, ch 5, turn. Work 1 row of sps, ch 3, turn (30 sps). Work 4 rows of sps decreasing on each row at armhole (28 sps). **Next row:** Ch 3, 1 s c in first sp, * 3 d c in next sp, 1 d c in s c, 3 d c into next sp, 1 s c in next sp, 6 sps, repeat from * to end of row. Ch 5, turn. **Following row:** Work same as 16th row ending with a full group of d c's. **Next row:** Sl st in 2nd d c, ch 3, 1 d c in each of the next 5 d c, 1 s c in next d c. Work same as 17th row, ch 5, turn. **Following row:** Work same as 18th row, working last s c in 4th d c of last group of d c's, ch 3, turn. Work 2 rows of sps decreasing on each row at armhole (25 sps).

Work 10 rows without decreasing. Work 1 row of sps, ch 3, turn. Continue working in pattern decreasing at neck same as armhole until there are 14 sps left, ending at neck, ch 5, turn. Work to within 3 sps of end of row, ch 3, turn. Work to end of row, ch 5, turn. Repeat last 2 rows until there are 2 sps left. Break off. Work other front to correspond.

Sleeve: Begin with ch 132, repeat same as for back (43 sps) for 14 rows. Sl st along 2 sps, ch 3, work along row in pattern to within 2 sps at other end, ch 3, turn. Continue working pattern decreasing same as armhole on each row until there are 8 sps left. Work 1 row even. Finish off. Work other sleeve to correspond.

Machine stitch side seams on inside shaping to fit figure. Sew up shoulder seams and sew in sleeves. Lift 2 darts at both sides of front about 3½" from front edge and 3½" from lower edge. Make darts 1½" in length and 1" apart.

Left Front Band: Begin with ch 22, 1 d c in 4th ch from hook, 1 d c in each of the next 18 ch, ch 3, turn (19 d c in all). * 1 d c in each d c of previous row, ch 3, turn. Repeat from * for 28". Sew band to edge of left front (16½"), mitre band at corner allowing 2½", sew along 3" at lower edge, mitre again and sew remaining 3½" upward on

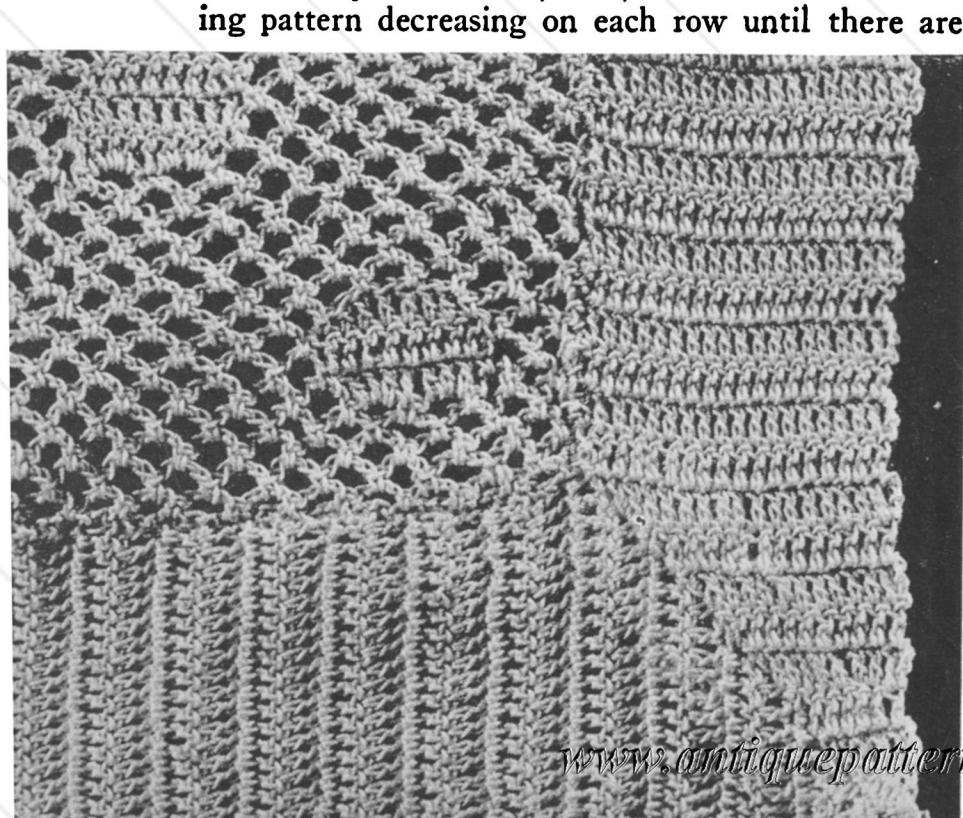

front, the end of band finishing at foot of darts. When mitring corners machine stitch diagonally, cut away surplus crochet at back leaving $\frac{1}{4}$ " seams. Press flat.

Right Front Band: Work same as other band until it measures 15". Make a buttonhole. To make buttonhole—work 6 d c, ch 7, skip 7 d c, 1 d c in each of the next 6 d c, ch 3, turn. Work 10 rows. Make another buttonhole. Repeat from * until there are 6 buttonholes. Continue working rows of d c's until band measures 28". Finish off. Sew to right front to correspond with left front.

Neckband: Begin with ch 22, 1 d c in 4th ch from hook, 1 d c in each of the next 17 ch, 1 half d c in last ch, ch 2, turn. * 1 half d c in half d c of previous row, 18 d c, ch 3, turn. 18 d c, 1 half d c, ch 2, turn, repeat from * for length required. Sew neckband to edge of neck.

Belt: Begin with ch 17, 1 d c in 4th ch from hook, 1 d c in each of the next 13 ch, ch 3, turn, * 1 d c in each d c of previous row, ch 3, turn, repeat from * for length required. Sew belt at edge of band at darts on left side, stretch across back of cardigan and sew to right side at darts. Sew on buttons.

Edgings

Crochet these interesting new designs with J. & P. Coats Tatting Cotton, size 70, either white or any of the lovely pastels. Steel crochet hook No. 12 or 14.

No. 8051: To make braid, ch 12, 1 tr in 1st st of ch, ch 5, turn. 1 tr in 7th st of last ch from beginning. * Ch 5, turn, skip last tr and ch-5 and make a tr under previous tr. Repeat from * for desired length.

Scallops: **1st row:** Make 6 s c under each of next 7 tr's along side of braid, 5 s c under next tr, ch 12, turn, skip last 9 s c's, 1 s c in next, ch 1, turn. 15 s c under ch-12, 1 s c under same sp of braid, 2 s c under next sp, ch 2, turn. **2nd row:** * Skip 1 s c on loop, d c in next, ch 2. Repeat from * 6 more times. After last ch-2, skip 2 s c on braid, s c in next, ch 1, turn. **3rd row:** * 2 s c under

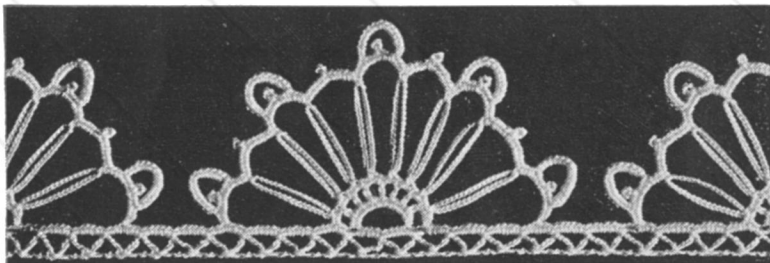

next ch-2, ch 35, 1 sl st in last s c, 1 s c under same ch-2. Repeat from * 7 more times. 4 s c under same sp on braid. 6 s c over each of next 2 sps, 3 s c under next sp, turn. **4th row:** * Ch 10, 1 s c in center of next ch-35 loop. Repeat from * 7 more times, ch 10, skip 18 s c's on braid, 1 s c in next, ch 1, turn. **5th row:** * 7 s c under next ch-10, a ch-5 p, 3 s c under same ch, ch 14, turn. Skip p and next 2 s c, 1 sl st in next s c, ch 1, turn. Work 15 s c under ch-14, 3 s c over rest of same ch-10. Under next ch-10 work 7 s c, p, 6 s c. Repeat from * around scallop. 3 s c in rest of same sp on braid. Repeat from 1st row of scallops.



No. 8056: Beginning at center of motif, ch 10, 1 tr in 1st st of ch, ch 1, turn. 14 s c under ch, 1 s c in 1st st of ch, turn. Ch 5, skip 2 s c, 1 s c in next. (Ch 5, skip 1 s c, 1 s c in next) 6 times, ch 8, turn. 1 s c in next loop. (Ch 5, 1 s c in next loop) 6 times, ch 2, 1 d c at base of 1st loop of last row, turn. (Ch 7, 1 s c in next loop) 7 times, ch 10, turn. 1 s c in next loop. (Ch 8, 1 s c in next loop) 6 times, ch 4, 1 tr in d c of last row, turn. (Ch 10, 1 s c in next loop) 7 times, ch 14, turn. 1 s c in next loop. (Ch 12, 1 s c in next) 6 times, ch 6, 1 d tr in tr of previous row, turn. (Ch 14, 1 s c in next loop) 7 times, ch 18, turn. 1 s c in next loop. (Ch 16, 1 s c in next loop) 6 times, ch 8, 1 d tr in d tr of previous row, turn. (Ch 12, a Clones

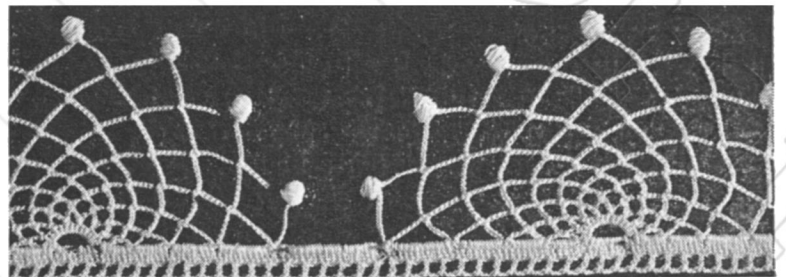

knot. To make Clones knot, see page 25. Ch 9, 1 s c in next loop) 7 times. Fasten off. Repeat 1st motif for as many motifs as necessary for desired length. Then place motifs side by side (right sides up with straight edge at bottom), and join one to the other as follows: Attach thread to one end loop at straight edge, ch 17, sl st in end loop of adjacent motif. Break off. Join all motifs in this way.

Heading row: Work a close row of d c's under ch's and connecting ch's of motifs on straight edge. Ch 4, turn. **2nd row:** Skip 2 d c, 1 d c in next. * Ch 2, skip 2 d c, 1 d c in next. Repeat from * and fasten off.

No. 8018. To make braid, ch 7, 1 d c in 1st st of ch, * ch 7, turn, 1 d c in last d c. Repeat from * for desired length. Fasten off. **Heading row:** Attach thread in ch-7 loop at beginning of braid, ch 13, 1 tr in next ch-7 loop on same side of braid, * ch 7, 1 tr in next loop on same side of braid. Repeat from * across.

Edging: Attach thread to 4th st of 1st ch-7 loop on

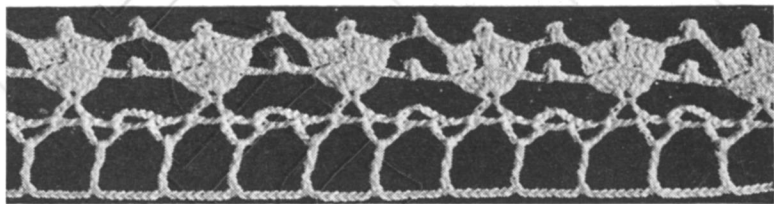

other side of braid, inserting hook through 1 loop only, ch 3, 6 d c in same st. * Ch 3, a ch-5 p, ch 4, skip next ch-7 loop, 7 d c in 4th st of next loop. Repeat from * across and fasten off. **2nd row:** Attach thread to ch-3 at beginning of last row. Ch 3, 1 d c in each of next 2 d c, * d c in next d c, a ch-5 p, d c in same d c as last d c, 1 d c in each of next 3 d c, ch 3, p, ch 3, 1 dc in each of 1st 3 d c of next scallop. Repeat from * across. Fasten off.

No. 8057: 1st row: * Ch 3, a ch-5 p. Repeat from * for desired length. 2nd row: Ch 6, p, ch 2, 1 d c under ch between 1st 2 p's of last row. * Ch 1, p, ch 1, 1 d c between next 2 p's. Repeat from * and fasten off. 3rd row: Attach thread at beginning of

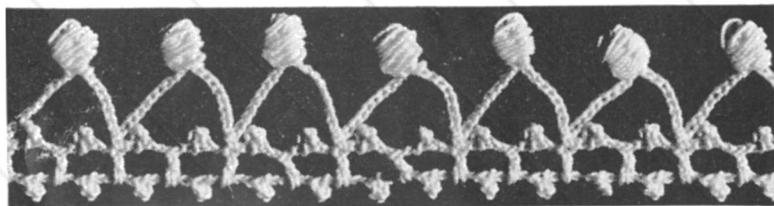

last row, to ch-6. * Ch 13, a Clones knot (to make Clones knot see page 25). Ch 9, skip next d c, 1 s c in next d c. Repeat from * and fasten off.

No. 8055: To make flowers, ch 13, a 2 d c-cluster in 5th ch from hook, a ch-4 p in top of d c, * ch 4, 1 sl st in same st at base of d c. ** Ch 5, a 2 d c-cluster in 1st st of this ch, p, ch 4, 1 sl st at

base of dc, repeat from ** 4 more times, ch 3, 1 tr between 3rd and 4th clusters, leaving 1 loop of tr on hook, skip 2 sts of ch next to 1st cluster, 1 sl st in next st, pulling sl st loop on through all loops on hook, 3 s c under next ch thus making stem. Ch 28, a 2 d c-cluster in 5th ch from hook, ch 2, sl st to ch-4 p of last cluster of adjacent flower, ch 2, sl st

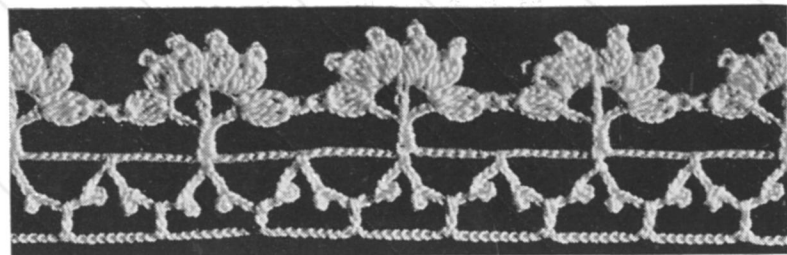

to tip of incompleting cluster, and repeat from * for desired length. **2nd row:** * ch 2, a ch-5 p, ch 4, p, ch 3, 1 s c in center st of next long ch between flowers of last row, ch 2, p, ch 4, p, ch 3, 1 s c in end s c of next flower stem, between long ch's. Repeat from *. **3rd row:** Ch 2, p, ch 13, turn, 1 d c in loop between the 2 p's of last row, * ch 9, 1 d c in next loop. Repeat from * across. Fasten off.

No. 8028: 1st row: * Ch 12 a Clones knot in 5th ch from hook (to make Clones knot, see page 25). Ch 5, a knot, 1 s c under ch-12 close to 1st knot. Then turn work around to left, keeping right side up. Make a sl st across between knots and repeat from * for desired length. **2nd row:** Ch 19, 1 tr

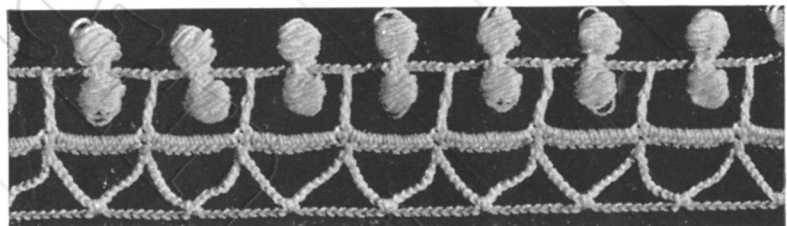

in center st of ch between 1st 2 groups of knots. * Ch 8, 1 tr in center st of next ch. Repeat from * to end of row. Fasten off. **3rd row:** Attach thread at beginning of last row and under each ch-8 work 9 s c, and 1 s c in each tr. Turn. **4th row:** * Ch 16, 1 s c in s c directly over next tr of 2nd row. Repeat from * across. Turn. **5th row:** Ch 16, 1 s c in next ch-16 loop, * ch 9, 1 s c in next loop. Repeat from * across and fasten off.

Popcorn Trail Bedspread No. 612

Materials: Clark's O.N.T. Knitting and Crochet Cotton, for double size spread, 10 x 12 blocks (finished size about 87 x 105 inches), 43 balls (plus 4 balls for fringe) of White or Ecru; for single size spread, 8 x 12 blocks (finished size about 70 x 105 inches), 35 balls (plus 3 balls for fringe). Steel crochet hook No. 4, 5 or 6.

Gauge: Blocks are 8¾ inches square. (Each block requires about 145 yards of thread. One side of block requires 38 yards for three-inch fringe.)

Beginning at center, ch 5, join with sl st to form ring. **1st rnd:** Ch 3 (to count as d c at beginning of each row), 2 d c in ring, * ch 2, 3 d c in ring, repeat from * 2 more times, ch 2, join with sl st to 3rd st of ch-3 first made. Join each rnd in this way. **2nd rnd:** Ch 3, d c in next d c (Pick up only the back

loop of st throughout.), 2 d c in sp, * ch 3, 2 d c in sp, d c in each of next 3 d c, 2 d c in next sp, repeat from * around, ending rnd with ch 3, 2 d c in sp, and join with sl st as before. **3rd rnd:** Ch 3, 1 pc st (to make a pc st, ch 1, 5 d c in next d c, drop st from hook, insert hook back in ch-1, pick up dropped loop and draw it through st on hook), d c in each of next 3 d c, 2 d c in next sp, * ch 3, 2 d c in same sp, d c in each of next 3 d c, 1 pc st, d c in each of next 3 d c, 2 d c in next sp, repeat from * around, ending rnd with d c in each of next 3 d c, join with sl st as before. **4th rnd:** Ch 3, * d c in next pc st, d c in next d c, 1 pc st, d c in each of next 3 d c, 2 d c in sp, ch 3, 2 d c in sp, d c in each of next 3 d c, 1 pc st, 1 d c in next d c, repeat from * around, join. **5th rnd:** Ch 3, * 1 pc st, d c in each of next 3 sts, 1

pc st, d c in each of next 3 d c, 2 d c in sp, ch 3, 2 d c in sp, d c in each of next 3 d c, 1 pc st, d c in each of next 3 sts, repeat from * around, join. **6th and 7th rnds:** Work in this manner, having 4 pc sts in a section in the 6th rnd and 5 pc sts in a section in the 7th rnd. **8th rnd:** Ch 3, d c in each of next 2 sts, * 1 pc st, d c in each of next 3 sts, 1 pc st, 7 d c, 2 d c in sp, ch 3, 2 d c in sp, 7 d c, 1 pc st, 3 d c, 1 pc st, 3 d c, repeat from * around (4 pc sts in each section). Join. **9th rnd:** Ch 3, * 1 pc st, 3 d c, 1 pc st, 7 d c, 1 pc st, 3 d c, 2 d c in sp, ch 3, 2 d c in sp, 3 d c, 1 pc st, 7 d c, 1 pc st, 3 d c, repeat from * around. Join. **10th rnd:** Ch 3, 2 d c, * 1 pc st, 11 d c, 1 pc st, 3 d c, 2 d c in sp, ch 3, 2 d c in sp, 3 d c, 1 pc st, 11 d c, 1 pc st, 3 d c, repeat from * around. Join. **11th rnd:** Ch 3, * 1 pc st, 15 d c, 1 pc st, 3 d c, 2 d c in sp, ch 3, 2 d c in sp, 3 d c, 1 pc st, 15 d c, repeat from * around. Join. **12th rnd:** Ch 3, 18 d c, * 1 pc st, 3 d c, 2 d c in sp, ch 3, 2 d c in sp, 3 d c, 1 pc st, 35 d c, repeat from * around. Join.

13th rnd: Ch 3, 20 d c, * 1 pc st, 3 d c, 2 d c in sp, ch 3, 2 d c in sp, 3 d c, 1 pc st, 39 d c, repeat from * around. Join. **14th rnd:** Ch 4, * skip 1 d c, d c in next, ch 1, repeat from * until 11 sps are made, * 1 pc st, 3 d c, 2 d c in sp, ch 3, 2 d c in sp, 3 d c, 1 pc st, 1 d c, 21 sps, repeat from * around. Join with sl st to 3rd st of ch-4 first made. **15th rnd:** Ch 4, d c in next d c, * ch 1, d c in next d c, and repeat from * until 11 sps are made, ** 2 d c, 1 pc st, 3 d c, 2 d c in sp, ch 3, 2 d c in sp, 3 d c, 1 pc st, 3 d c, 21 sps, repeat from ** around. Join. **16th rnd:** Ch 4, 11 sps, * 4 d c, 1 pc st, 3 d c, 2 d c in sp, ch 3, 2 d c in sp, 3 d c, 1 pc st, 5 d c, 21 sps, repeat from * around. Join. Break off.

Joining Blocks. Join edges of blocks together on wrong side with over and over sts using the same thread. Then work a row of sps all around spread.

Fringe. For fringe, knot 4 strands of 10 inches long (5 inches when doubled), cotton into each space all around spread.

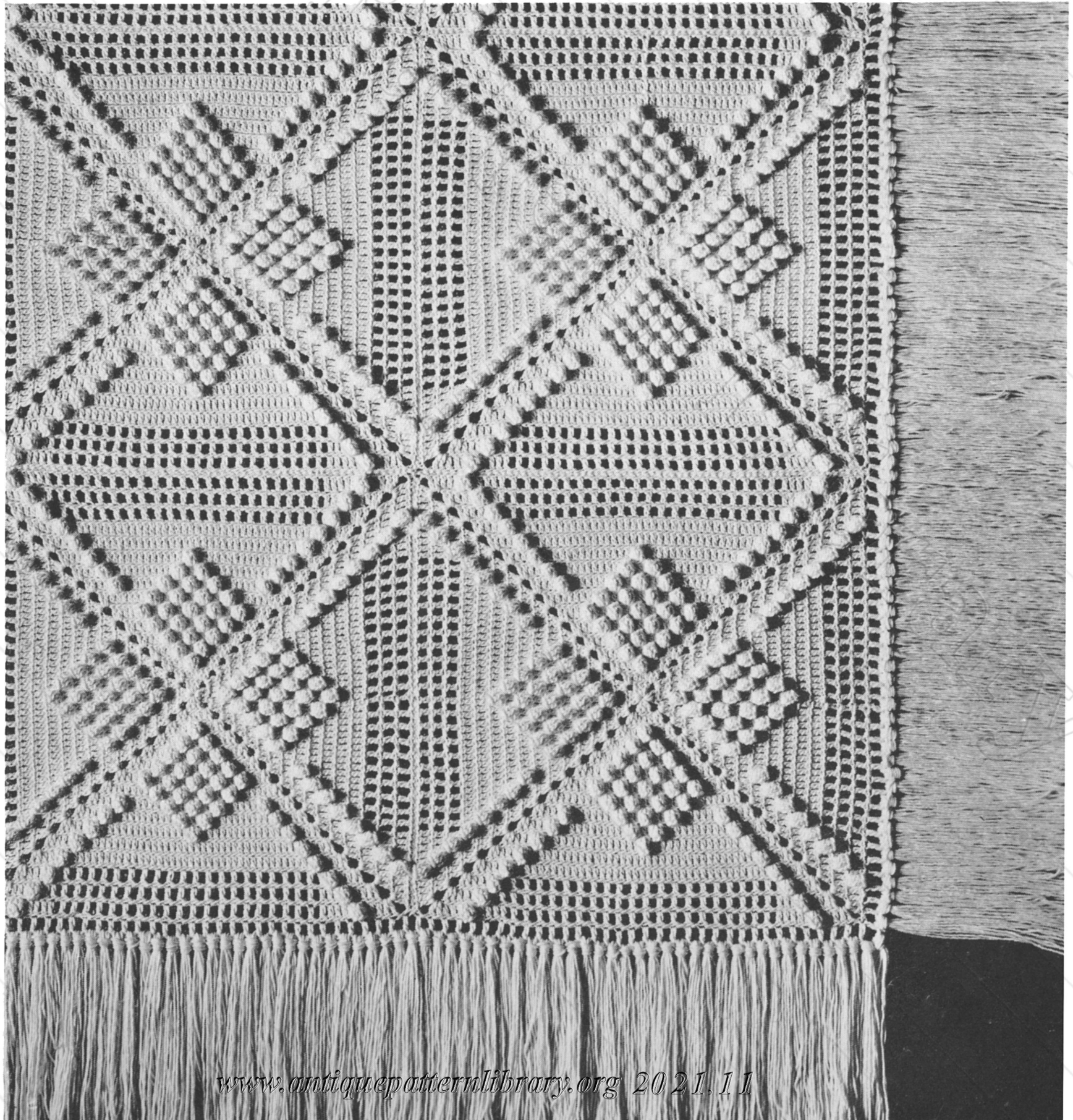



Flower Field Mat No. 7011

Materials: Clark's O.N.T. Cronita, 2 balls of Ecu. Steel crochet hook No. 4 or 5.

Each motif is joined on to previous motifs on the 4th rnd, as explained later. **First motif.** Ch 6, join with sl st to form ring. **1st rnd:** Ch 3, 15 d c in ring, join with sl st to 3rd st of ch-3 first made. **2nd rnd:** Ch 4, d c in each d c with ch-1 between d c's. Join with sl st to 3rd st of ch-4 (16 sps). **3rd rnd:** Ch 5, d c in next sp, * ch 4, skip 1 sp, 2 d c with ch-2 between in next sp, repeat from * around, ending with ch 4 and sl st to 3rd st of ch-5 first made. **4th rnd:** Ch 3, 4 d c in next sp, 5 d c in each of next 2 sps, * ch 13, skip 1 sp, 5 d c in each of next 3 sps, repeat from * 2 more times, then ch 13 and join with sl st to 3rd st of ch-3 first made. Break off. **Second Motif.** Work as for first motif to 3rd rnd incl. **4th rnd:** Ch 3, 4 d c in next sp, join with s c between 1st and 2nd groups of 5-dc on first motif (always keeping right side of work on top), make 5 d c in next sp back on second motif, and join again in the same way with s c between

2nd and 3rd groups of 5-dc on first motif, 5 d c in next sp back on second motif, ch 6, join with sl st to 7th ch st of first motif, ch 6, skip 1 sp on second motif, 5 d c in next sp. Complete this rnd as in first motif with no more joinings to within the last ch-13. Then ch 6, join with sl st to 7th ch st of ch-13 on first motif, ch 6, join with sl st to 3rd st of ch-3 first made on second motif. Break off.

Make 4 more motifs joining each motif to previous one as second one was joined to first, thus making a strip of 6 motifs. Make a second strip of 6 motifs joining to first strip, as follows: **First Motif of Second Strip.** Work as for second motif of first strip and join, as before, to first motif alongside of first strip. **Second motif.** Work as before to 3rd rnd inclusive. **4th rnd:** Work as for 4th rnd of previous motif, but join to the two adjacent motifs and complete rnd. Work next 4 motifs of this strip joining thus to adjacent two motifs. For a place mat, 6 x 8 motifs, work 6 more strips and join as before.

Hailstone Medallion Table Mat No. 771

Materials: Clark's O.N.T. or J. & P. Coats Mercerized Crochet Size 50, 2 balls. Steel Crochet hook No. 14. Fine linen.

Medallion. 1st rnd: Ch 13, make a Clones knot; **To Make Clones Knot**, thread over, insert hook in 4th ch from hook and draw up a loop, bring it forward and up and thread over again as for a d c. Continue to draw up loops from over and under the ch for 8 times (16 loops over hook), draw thread through all loops on hook at once, thread over and draw through loop on hook, then make a s c around ch at base of knot drawing tight, which completes the knot. Then ch 2, 1 tr tr in 1st st of ch, * ch 6, 1 knot, ch 2, 1 tr tr in same st, repeat from * 9 more times, then ch 6, 1 knot, ch 2, sl st in 9th st of first ch-16. **2nd rnd:** Ch 18, 1 knot, ch 4, 1 tr tr in next tr tr, * ch 9, 1 knot, ch 4, 1 tr tr in next tr tr, repeat from * 9 more times, ch 9, 1 knot, ch 4, sl st in 9th st of first ch-18. **3rd rnd:** Ch 20, 1 knot, ch 7, 1 tr tr in next tr tr, * ch 11, 1 knot, ch 7, 1 tr tr in next tr tr, repeat from * 9 more times, ch 11, 1 knot, ch 7, sl st in 9th st of first ch-20. **4th rnd:** Ch 28, 1 long tr (thread over 6 times) in next tr tr, * ch 33, 1 long tr in next tr tr, ch 19, 1 tr tr in next tr tr, ch 19, 1 long tr in next tr tr, repeat from * once more, ch 33, 1 long tr in next tr tr, ch 19, sl st in 9th st of first

ch-28. Mark the 17th st of each ch-33 loop with a pin (these are the corner sts). **5th rnd:** Ch 3, 21 d c under next ch loop, 1 d c in long tr, 17 d c under first half of next loop, 5 d c in marked st, 17 d c under next half of loop, 1 d c in next long tr, 21 d c under next loop, 1 d c in next tr tr. Continue around, joining last d c to starting ch-3 with a sl st. **6th rnd:** Ch 5, skip 2 d c, d c in next, ch 2, skip 2 d c, d c in next (1 sp). Continue making sps all around, in each corner d c making the following:—1 d c, ch 3, 1 d c, ch 3, 1 d c. Break thread. Make 7 medallions. Hem 4 squares of linen the same size as medallions, and 4 more with the corners curved as in illustration. Let the outer side of the row of sps of each of the 6 medallions around the outside of runner extend out beyond the linen, then to make all outer edges even, work sps into the linen edges. When this is done, work around entire runner as follows: 3 s c under each ch-2, with a ch-5 p after every 12th s c. Break thread. **Next rnd:** Attach thread in 6th s c from a p, * ch 15, 1 knot, ch 11, s c in 6th st from next p, repeat from * around.

Larger mats can be made by crocheting more medallions and making more squares of linen. 4 such mats and a larger runner would make a very attractive luncheon set.

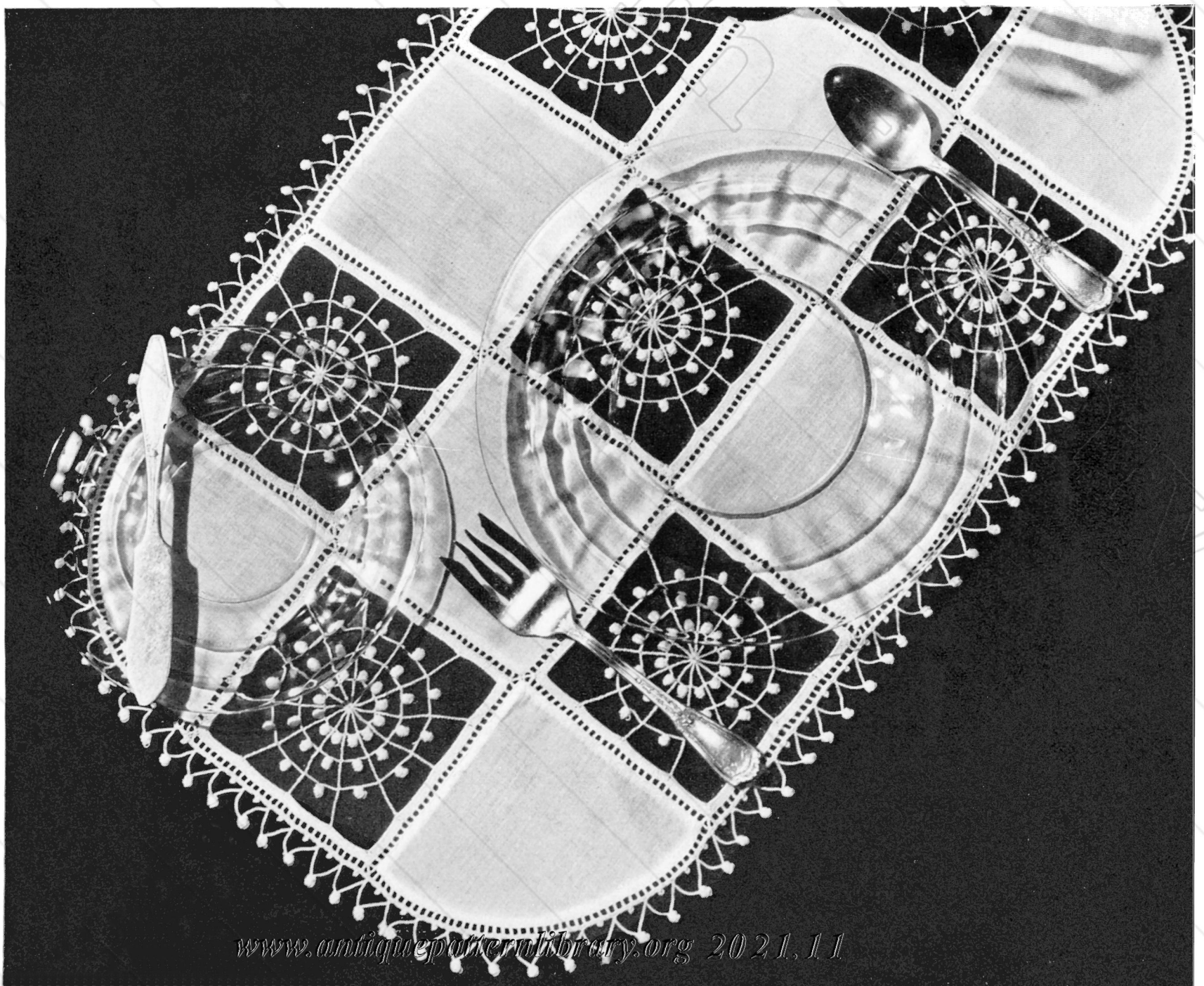

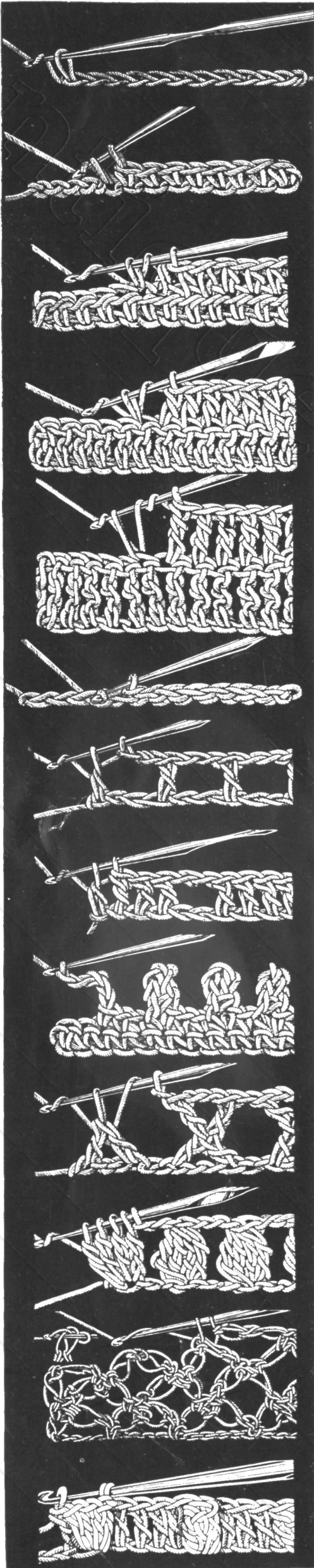

CROCHET STITCHES and how to make them

Chain (ch). Make loop in thread, insert hook in loop, and draw main length of thread through. Continue to draw thread through each new loop formed until length desired.

Single Crochet (s c). Insert hook under 2 loops of st, draw thread through st (2 loops on hook), thread over hook, draw through the 2 loops.

Half Double Crochet (half d c). Make like d c until there are 3 loops on hook; then thread over and draw through all 3 loops.

Double Crochet (d c). Thread over hook, insert hook in st, and draw thread through (3 loops on hook), thread over hook, draw through 2 loops, thread over, and draw through the 2 remaining loops.

Treble (tr). Thread over hook twice, insert hook in st and draw thread through st (4 loops on hook), thread over, draw through 2 loops, thread over, draw through 2 loops, thread over, draw through remaining 2 loops. For a **Double Treble (d tr)**, thread over hook 3 times; and for a **Triple Treble (tr tr)**, thread over 4 times, taking off 2 loops at a time as in the tr.

Slip Stitch (sl st). Insert hook through st, catch thread, and, with one motion, draw through both the st and the 1 loop on hook. The sl st is used for joining, or when an invisible st is required.

Block (bl) and Space (sp). Make 4 d c over 4 sts of preceding row (this forms 1 bl), ch 2, skip 2 sts, make 1 sp. The bl and sp are used in Filet Crochet.

Picot (p). Make a ch of 3, 4, or 5 sts, according to length of p desired, and s c in the foundation, or in the 1st st of ch.

Cross Stitch. Thread over twice, insert hook in st and draw thread through as for a tr (4 loops on hook), thread over, and draw through 2 loops, thread over, skip 2 sts, insert hook in next st, draw thread through (5 loops on hook), thread over and draw off 2 loops at a time 4 times, ch 2, 1 d c in the center point of the cross, thus completing the cross.

Cluster. Make 3 or more tr in the same st, always holding the last loop of each tr on the hook; then, thread over hook and take off all remaining loops. A tight ch st should then be made to fasten the cluster.

Knot Stitch. Draw a loop on hook out $\frac{1}{4}$ inch, draw thread through, making a ch st of it. Put hook between loop and single thread of this ch and make an s c. Work another similar knot st, skip 4 sts of preceding row, 1 s c in next. Repeat from the beginning to end of row. Make $2\frac{3}{8}$ -inch knot sts to turn, 1 s c over double loop at right of 1st center knot of preceding row, 1 s c over double loop at left of same knot, 2 knot sts and repeat.

Popcorn Stitch (pc st). Ch 1, 5 d c in next st, drop st from hook, insert hook back in ch-1 and draw loop through the one on hook.

THE SECRET OF LOVELY ART NEEDLEWORK



YOU are sure of making lovely things when you use Clark's O.N.T. and J. & P. Coats cottons. Their quality is famous. They are a pleasure to work with, neither shrink nor scratch, are Boilfast †, and give year-round wear and lasting beauty. Clark's O.N.T. and J. & P. Coats Mercerized Crochet are the aristocrats of crochet cottons. They are firmly twisted from six cords and have exceptionally high lustre, strength and workability. Clark's O.N.T. Cronita is lovely soft-lustre cotton, mercerized, soft-twisted, equally suited for fashion and household articles. Clark's O.N.T. Knitting and Crochet Cotton is a non-mercerized, soft-twisted cotton of smoothly dull finish, used for garments, accessories, household things—ideal for bedspreads.

† Trade mark.

THE SPOOL COTTON CO., 350 FIFTH AVENUE, NEW YORK, N. Y.

Creative Commons 4.0 NC SA BY FREE DISTRIBUTION ONLY - NOT FOR SALE

Choice Designs in

CROCHET



BOOK 69

www.antiquepatternlibrary.org 2021.11

10 CENTS